

# Mortise Lock Installation Instructions

Updated October 2016

*Fits doors  
1-3/8" to 1-3/4"  
thick*

# Mortise

**A** American mortise locks were made by many different manufacturers. And, there was not a set standard for their sizes. Consequently, installation of a Nostalgic Warehouse replacement mortise lockset may require modification to your door.

NOTE: DETERMINE DOOR HANDING BEFORE PROCEEDING TO STEP B, AS THIS DETERMINES THE LOCK TONGUE BEVEL.

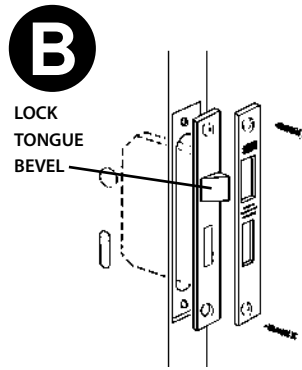

- 1) Insert mortise lock into door.
- 2) Attach faceplate using 3/4" wood screws.

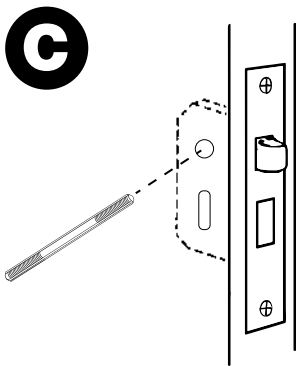

Install solid spindle to help position door plate for mounting.



- 1) Insert nylon bushing over spindle, and into door trim.

- 2) Make plate parallel with door edge, and mark the mounting holes.
- 3) Remove the plate, and drill the mounting holes using 7/64" bit.
- 4) Replace the plate and insert the nylon bushing.
- 5) Mount using 3/4" wood screws.
- 6) Repeat for opposite side of door.

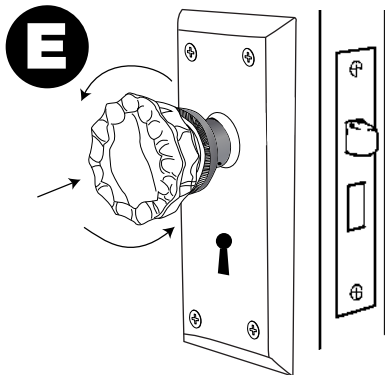

Screw knobs onto centered spindle.

Do not over-tighten!

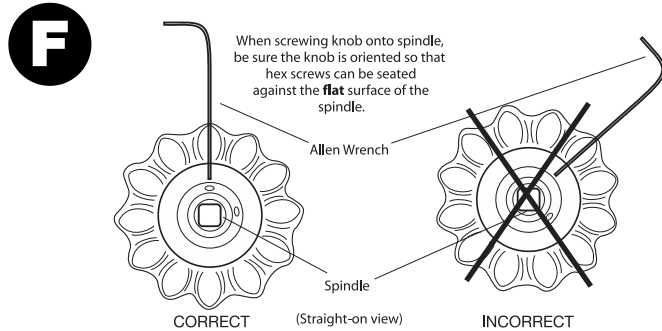

**G** Tighten both hex screws on each knob. If knobs do not turn freely, rotate one knob counter-clockwise 1/4 turn, and retighten hex screws. Repeat process until both knobs turn freely.

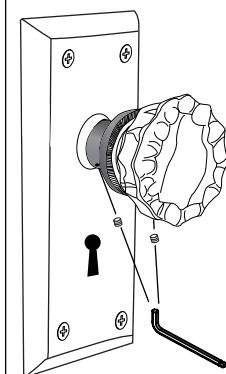

Additional skeleton keys are available for purchase by calling Customer Service at 800-522-7336.

# Mortise Lock Handing Instructions

---

**A**



LEFT HAND LOCK SHOWN

Remove the screw that holds the mortise chassis together. Put it in a safe place so it will not be lost.

**CAUTION  
WEAR SAFETY  
GLASSES**

**B**



LEFT HAND LOCK SHOWN

Gently remove the cover of the mortise lock that is facing you. Be careful to keep all internal parts in their original positions.

**C**

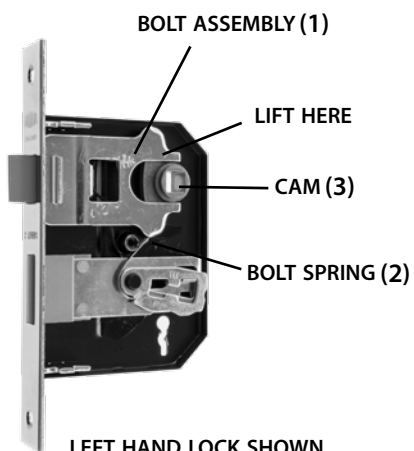

LEFT HAND LOCK SHOWN

Gently lift the RH end of the bolt assembly (1) and release the tension on the bolt spring (2). Remove bolt assembly.

# Mortise Lock Handing Instructions

**D**

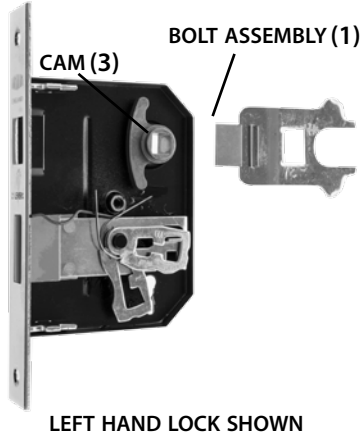

Remove cam (3).

**E**

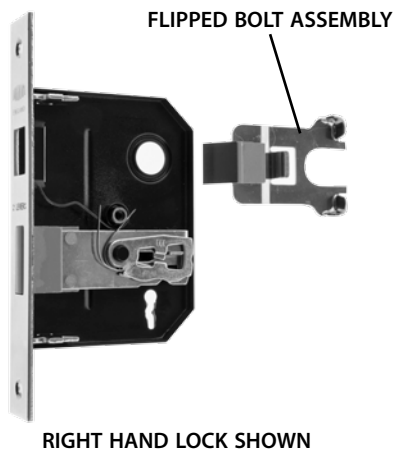

Flip bolt assembly over so it is opposite its original orientation, and insert into mortise lock.

Insert the cam on top of the bolt assembly for RH locks.

**F**

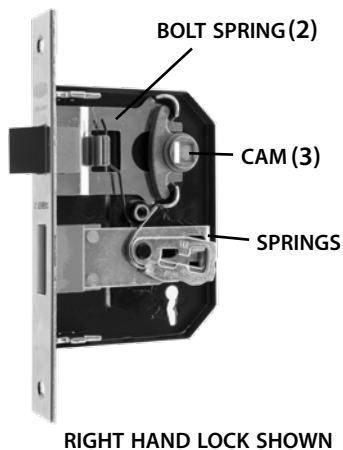

Put bolt spring (2) back in its original position. This will push the bolt assembly (1) out.

Make certain noted springs are in the correct location.

Rotate the cam (3) with the spindle (attached to a knob) to test operation. Replace the cover, and attach with screw.

# MORTISE LOCK DRILLING TEMPLATE

(Scale 1:1)

