



Kraus Kitchen Soap Dispenser

KSD-53

KSD-54

Congratulations on the purchase of your new Kraus® plumbing fixture!

Please keep the box and packaging materials until your product is completely installed. If you have any questions, require technical assistance or have any problems with your product:



DO NOT RETURN TO STORE

**Please contact our Customer Service Team
1-800-775-0703 / customerservice@kraususa.com**

Have the model number available and retain a copy of your receipt with purchase date for reference.

If for any reason this product does not meet your expectations, please be sure to repack this product in the original box and packaging material to avoid damage during transit.



PRIOR TO INSTALLATION

- Make sure you have all necessary parts by checking the diagram and parts list. If any part is missing or damaged, please contact Kraus' Customer Service at 800-775-0703 for a replacement
- Pre-drilled hole size requirement: 1-1/4"
- Max countertop thickness without deck plate: 2-1/4"

For technical assistance or replacement parts, please contact Kraus Customer Service and one of our representatives will be happy to help:
Toll-Free: 800-775-0703 or Customerservice@kraususa.com

The step-by-step guidelines in the installation instructions are a general reference for installing a Kraus Soap Dispenser. Should there be any discrepancies, Kraus cannot be held liable. It is recommended to install all Kraus products by hiring a licensed professional.

Diagram and Parts List

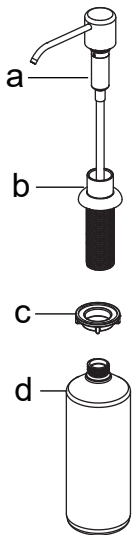

- a. Pump
- b. Dispenser Base
- c. Mounting Nut
- d. Dispenser Bottle

Step 1

Disassemble soap dispenser.

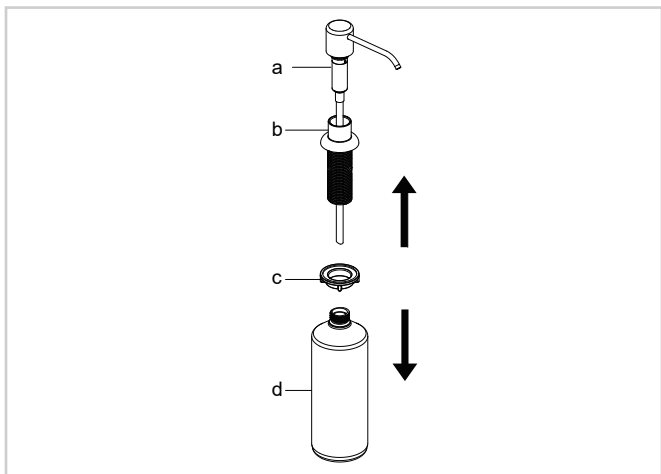

Step 2

Install dispenser base (b) attached into the hole in the countertop.
Reinstall mounting nut (c) on the dispenser base (b) from underneath the countertop. Tighten mounting nut (c) by hand.

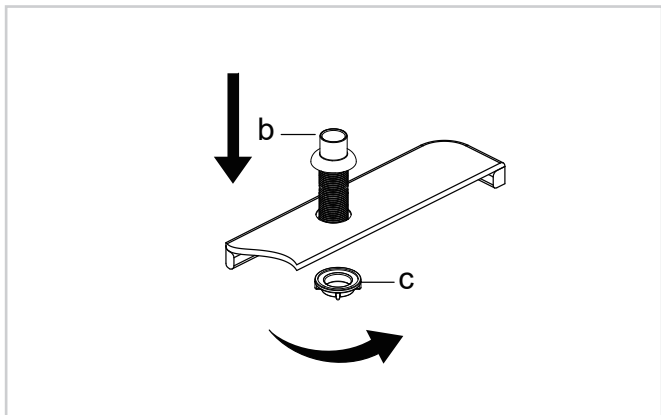

Step 3

Screw the dispenser bottle (e) to the dispenser base (b) from underneath the countertop. Tighten as required. Fill the dispenser bottle (e) from the top with up to 17 ounces of soap.

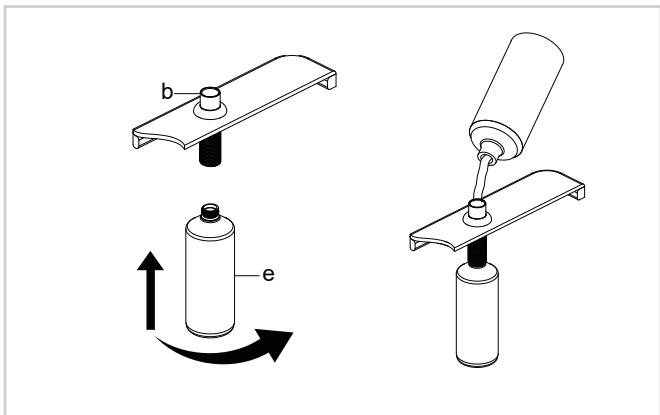

Step 4

Reinsert pump (a) into dispenser base (b) from the top. Press the pump several times to make sure soap is evenly distributed.

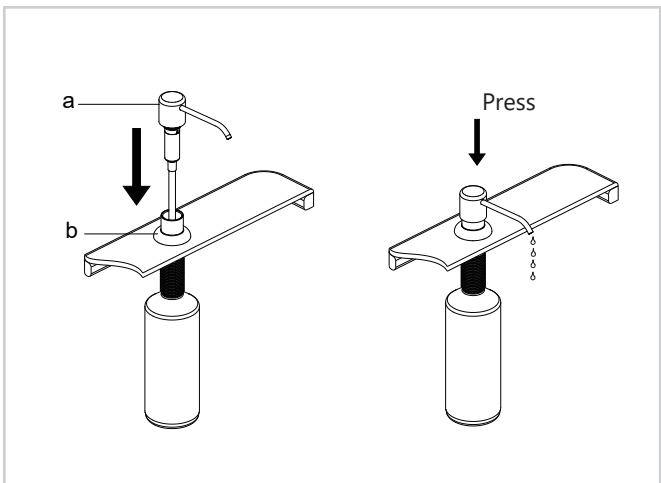

Replacement Parts

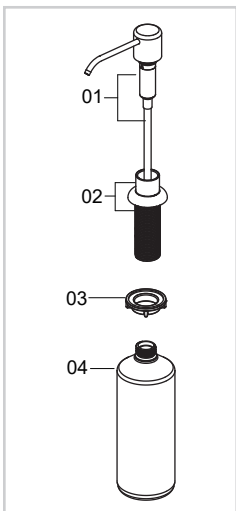

Replacement Parts List	Finish / Color	Part #
1. Pump		KP27131
2. Dispenser Base	CH, SFS, MB, ORB, SFACB, SFSB, BB, SFSMB, SS*	KP27134 (For KSD-53) KP27376 (For KSD-54)
3. Mounting Nut		KP27136
4. Dispenser Bottle		KP27137

*Denotes soap dispenser component color options:

CH - Chrome

SFS - Spot Free Stainless Steel

MB - Matte Black

ORB - Oil Rubbed Bronze

SFACB - Spot Free Antique Champagne Bronze

SFSB - Spot Free Black Stainless

BB - Brushed Brass

SFSMB - Spot Free Stainless Steel/Matte Black

SS - Stainless Steel PVD

Accessories

Kraus[®] USA Plumbing, LLC ("Kraus") extends this warranty to the original purchaser for personal household use of the Accessories when purchased from an authorized Kraus dealer and in the location of original installation. This warranty is non-transferable.

Kraus warrants the structure and finish of the Accessories to be free from defects in material and workmanship under normal usage for a period of one (1) year from the date of purchase.

Any product reported to the authorized dealer or to Kraus as being defective within the warranty period will be repaired or replaced with a product of equal value at the option of Kraus.

Commercial Warranty

Kraus USA Plumbing, LLC ("Kraus") warrants its Products for a period of one (1) year to commercial purchasers of Products used in industrial, commercial and business applications.

Care and Cleaning Instructions

Certain cleaning products may cause damage to a Product's finish and use of the following on the Product will void this warranty:

- Abrasive cleaners such as powders, bleach, ammonia, alcohol or chorine
- Abrasive pads, steel wool or wire brushes

What is Not Covered

This warranty does not cover Products that were discontinued when purchased or display Products, whether such Products were purchased at discount outlets, unauthorized dealers, and/or sold on clearance. This warranty does not cover any free gifts included with purchase.

This warranty does not cover damage resulting from neglect, misuse (including use for an unintended application), abuse, carelessness, accident, hard water or mineral deposits, exposure to corrosive materials, improper maintenance, alteration of the Product, or failure to follow care, cleaning or installation instructions enclosed with your Product. Kraus recommends that all Kraus Products be installed by a fully licensed and insured trade professional with experience in the installation of bathroom and/or kitchen manufactured goods.

Download the Kraus Care & Maintenance Guide at:
<http://www.kraususa.com/maintenance>

How to Make a Warranty Claim

If you are a **consumer purchaser**, please contact a Kraus[®] Customer Service Representative at:

Kraus USA Plumbing, LLC
12 Harbor Park Drive
Port Washington, NY 11050
Toll-free 800-775-0703
Customerservice@kraususa.com

If you are a **plumbing contractor or trade professional**, please contact a Kraus Pro Representative at:

Kraus USA Plumbing, LLC
12 Harbor Park Drive
Port Washington, NY 11050
516-801-8955
Proservice@kraususa.com

If you are an **authorized partner**, please contact a Partner Support Representative at:

Kraus USA Plumbing, LLC
12 Harbor Park Drive
Port Washington, NY 11050
516-801-8954
Partnersupport@kraususa.com

In requesting warranty service, please be ready to provide your proof of purchase and a description of the problem. Shipping charges will be covered for the first (1) year of the warranted replacement part or product (HI, AK, and Puerto Rico shipping charges may apply). International shipping fees are not included.

Limitation on Duration of Implied Warranties

Please note that some states/provinces (including Quebec) do not allow limitations on how long an implied warranty lasts, so the below limitations may not apply to you. TO THE MAXIMUM EXTENT PERMITTED BY APPLICABLE LAW, ANY IMPLIED WARRANTY, INCLUDING THE IMPLIED WARRANTIES OF MERCHANTABILITY AND OF FITNESS FOR A PARTICULAR PURPOSE, IS LIMITED TO THE STATUTORY PERIOD OR THE DURATION OF THIS WARRANTY, WHICHEVER IS SHORTER.

Limitation of Special, Incidental or Consequential Damages

Please note that some states/provinces (including Quebec) do not allow the exclusion or limitation of special, incidental or consequential damages, so the below limitations and exclusions may not apply to you. TO THE MAXIMUM EXTENT PERMITTED BY APPLICABLE LAW, THIS WARRANTY DOES NOT COVER, AND KRAUS USA PLUMBING, LLC SHALL NOT BE LIABLE FOR, ANY SPECIAL, INCIDENTAL OR CONSEQUENTIAL DAMAGES (INCLUDING LABOR CHARGES TO REPAIR, REPLACE, INSTALL OR REMOVE THIS PRODUCT), WHETHER ARISING OUT OF BREACH OF ANY EXPRESS OR IMPLIED WARRANTY, BREACH OF CONTRACT, TORT, OR OTHERWISE.

This warranty gives you specific legal rights, and you may also have other rights which vary from state/province to state/province.

IMPORTANT

Register Your Kraus Product

Activate Your Warranty

Access Premium Customer Support

Get Product Information

REGISTER TODAY

<http://www.kraususa.com/registration>



Kräus[®]
www.kraususa.com