

FFFU16F2V V/W

UPRIGHT FREEZER

15.5 CU. FT. FROST-FREE

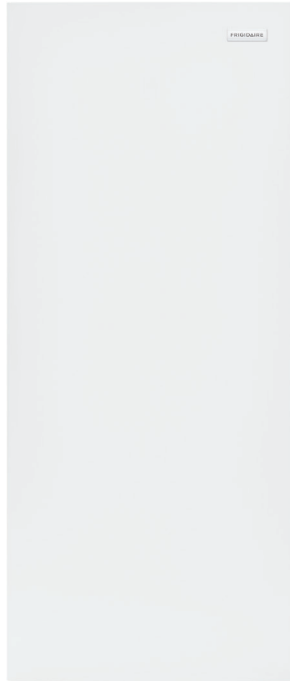

AVAILABLE COLORS



White



Brushed Steel

PRODUCT DIMENSIONS

Height (Including Hinges) 67-3/4"

Width 27-3/4"

Depth (Including Door) 29"

MORE EASY-TO-USE FEATURES

Frost-Free Design

Never waste time chipping away ice in your freezer again with our frost-free design that does the work for you.

Floor-Projected Power-On Indicator

Know at a glance that your freezer is keeping your favorites safely frozen and fresh with our power-on indicator light.

SIGNATURE FEATURES

Power Outage Assurance

Keep food frozen for over two days if there is a power outage with our superior tight seal that locks in cold air.

EvenTemp® Cooling System

Our EvenTemp® cooling system constantly circulates cold air throughout the freezer with smart sensing technology that adjusts air flow to maintain a uniform temperature.

Flexible Interior Organization System

Easily organize your family's frozen favorites with our four adjustable, metallic wire shelves, deep bottom basket, and five spacious door bins that allow you to make the most of every available square inch of your freezer.

Door Ajar Alarm

Monitor the ideal environment for your frozen foods with our audible temperature alarm that alerts you if the door is left open or the freezer's temperature rises.

FFFU16F2V W/V UPRIGHT FREEZER

15.5 CU. FT. FROST-FREE

FRIGIDAIRE

FEATURES

Door Handle Design	Pocket Handle
Reversible Door	Yes
Leveling Legs	Yes
Defrost	Frost-Free
Adjustable Temperature Control	Mechanical Dial
Temp Display Mode	Three settings (cold, recommended, coldest)
High-Temp Alarm	Yes
Door Ajar Alarm	Yes
Airflow Ports	5
Interior Lighting	LED
Full-Width Adjustable Shelves	4 Wire
Metallic Wire Basket	1
Full-Width Door Bins	5
Defrost Drain	Yes
Power-On Light	Yes

CERTIFICATIONS

CSA Rating	Household
------------	-----------

SPECIFICATIONS

Total Capacity (Cu. Ft.)	15.5
Shelf Area (Sq. Ft.)	9.81
Annual Energy (kWH)	461
Annual Energy Cost (.12/kWH)	\$55
Power Supply Connection location	Lower Right Rear
Voltage Rating	115V, 60Hz
Amps @ 115 Volts	1.9
Minimum Circuit Required (Amps)	15
Shipping Weight (Approx.)	159 Lbs.

¹An electrical supply with grounded three-prong receptacle is required. The power supply circuit must be installed in accordance with current edition of National Electrical Code (NFPA 70) and local codes & ordinances.

PRODUCT DIMENSIONS

A - Height (Including Hinges)	67-3/4"
B - Width	27-3/4"
C - Depth (Including Door)	29-1/8"
D - Depth with Door Open 90°	55-3/4"

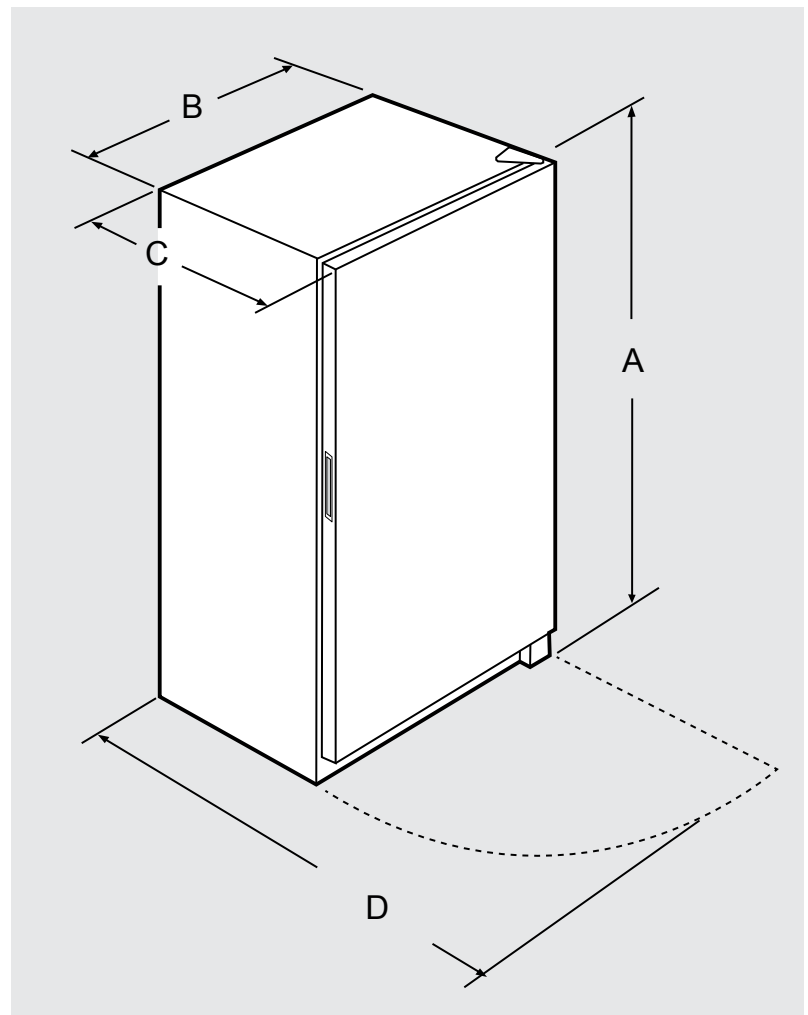

Note: For planning purposes only. Always consult local and national electric, gas and plumbing codes. Refer to Product Installation Guide for detailed installation instructions on the web at frigidaire.com / frigidaire.ca. Specifications subject to change. Accessories information available on the web at frigidaire.com / frigidaire.ca

FRIGIDAIRE

USA • 10200 David Taylor Drive • Charlotte, NC 28262 • 1-800-FRIGIDAIRE • frigidaire.com
CANADA • 5855 Terry Fox Way • Mississauga, ON L5V 3E4 • 1-800-265-8352 • frigidaire.ca

FFFU16F2V 12/19
©2019 Electrolux Home Products, Inc.