



**MANUAL DE MONTAGEM
ASSEMBLY INSTRUCTIONS
INSTRUCCIONES DE MONTAJE**

**COD BR: BPP 201-155, BPP 201-156
COD US: 122AMC155**

Sumário Summary Resumen

| | | |
|--|-------|---|
| Introdução Introduction Introducción | | 3 |
| Antes de começar Before starting Antes de comenzar | | 4 |
| Evite acidentes Avoid accidents Evitar accidentes | | 4 |
| Dimensões e ferramentas Dimensions and tools Dimensiones y herramientas | | 5 |
| Identificação das peças Identifying parts Identificación de las piezas | | 6 |
| Acessórios incluídos na caixa Hardware included in box Accesorios incluidos en la caja | | 7 |
| Montagem do móvel Furniture assembly Montaje del mueble | | 8 |

Introdução Introduction Introducción

Leia atentamente este manual e siga os passos indicados para uma perfeita montagem.
Read this manual and follow the steps for the perfect fit.
Lea este manual y siga los pasos para el ajuste perfecto.

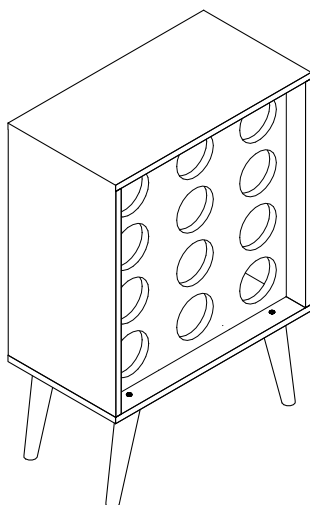

Antes de começar Before starting Antes de comenzar

Antes de começar a montagem prepare o ambiente, deixando-o completamente limpo e com bom espaço para iniciar o trabalho.

Prepare the room before starting the assembly, leaving it completely clean and the area in good condition to start the work.

Antes de comenzar el montaje preparar el ambiente, dejándolo completamente limpio y con bueno espacio para comenzar el trabajo.

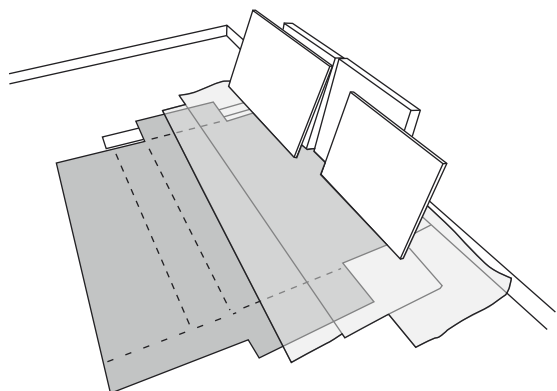

Utilize o papelão da própria embalagem para separar e apoiar as peças retiradas das caixas.

Use the cardboard of the packaging to separate and support the parts removed from the boxes.

Utilice el cartón de la embalaje para separar y apoyar las piezas desmontadas de las cajas.



Forre a área de montagem com um cobertor ou tapete. Assim, você evita avarias nas peças durante o processo de montagem.

Cover the assembly area with a blanket or carpet to avoid damaging the parts during the assembly process.

Cubrir la zona de ensamble con una manta o alfombra. De este modo, se evitan daños en las piezas durante el proceso de montaje.

Evite acidentes Avoid accidents Prevenir accidentes

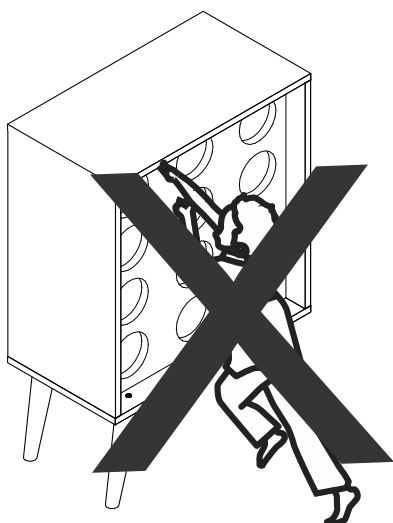

Não escale ou se apoie no móvel.

Do not climb or lean on the furniture.

No se suba ni se apoye en el mueble.

Dimensões e ferramentas
Dimensions and tools
Dimensiones y herramientas

Dimensões:

L: 535 A: 785 P: 294 mm

Dimensions:

W: 19.93 H: 21.06 D: 11.57 inches

Dimensiones:

L: 535 A: 785 P: 294 mm

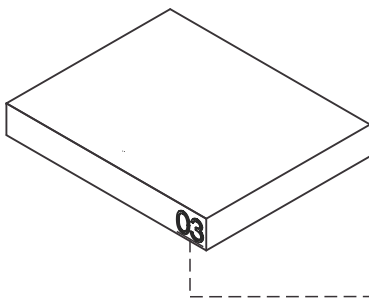
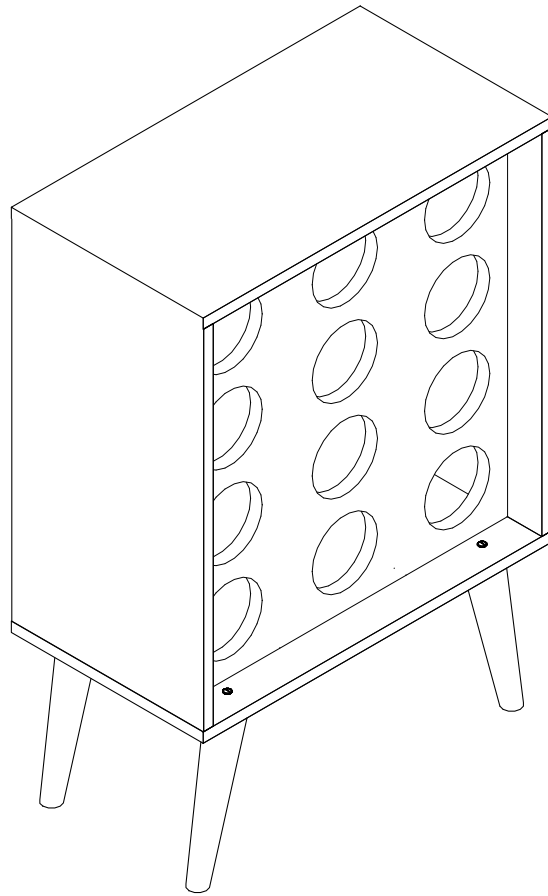

UTILIZE ALCOOL PARA REMOVER O NUMERO DAS PEÇAS
USE ALCOHOL TO REMOVE PART NUMBERS
UTILICE ALCOHOL PARA ELIMINAR EL NUMERO DE LAS PIEZAS

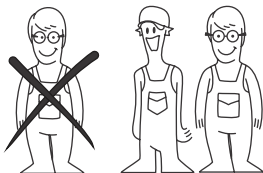

Para facilitar a montagem, utilize uma parafusadeira elétrica.
To improve assembly, use an electronic screwdriver.
Para facilitar el armado, utilice un destornillador eléctrico.

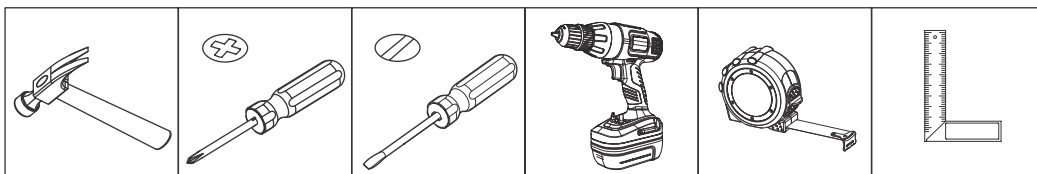

COD BR: BPP 201-155, BPP 201-156
 COD US: 122AMC155

| PEÇA | DESCRIÇÃO | QUANT. |
|------|--------------|--------|
| 001 | BASE | 1 |
| 002 | TAMPO | 1 |
| 003 | SIDE | 2 |
| 004 | FRENTE/COSTA | 2 |
| 005 | PÉS | 4 |

| PART | DESCRIPTION | QTY |
|------|-------------|-----|
| 001 | BASE | 1 |
| 002 | TOP | 1 |
| 003 | SIDE | 2 |
| 004 | FRNT/BACK | 2 |
| 006 | FEET | 4 |

| PIEZA | DESCRIPCIÓN | CANTIDAD |
|-------|--------------|----------|
| 001 | BASE | 1 |
| 002 | TAPA | 1 |
| 003 | SIDE | 2 |
| 004 | FRENTE/REVÉS | 2 |
| 006 | PIES | 4 |

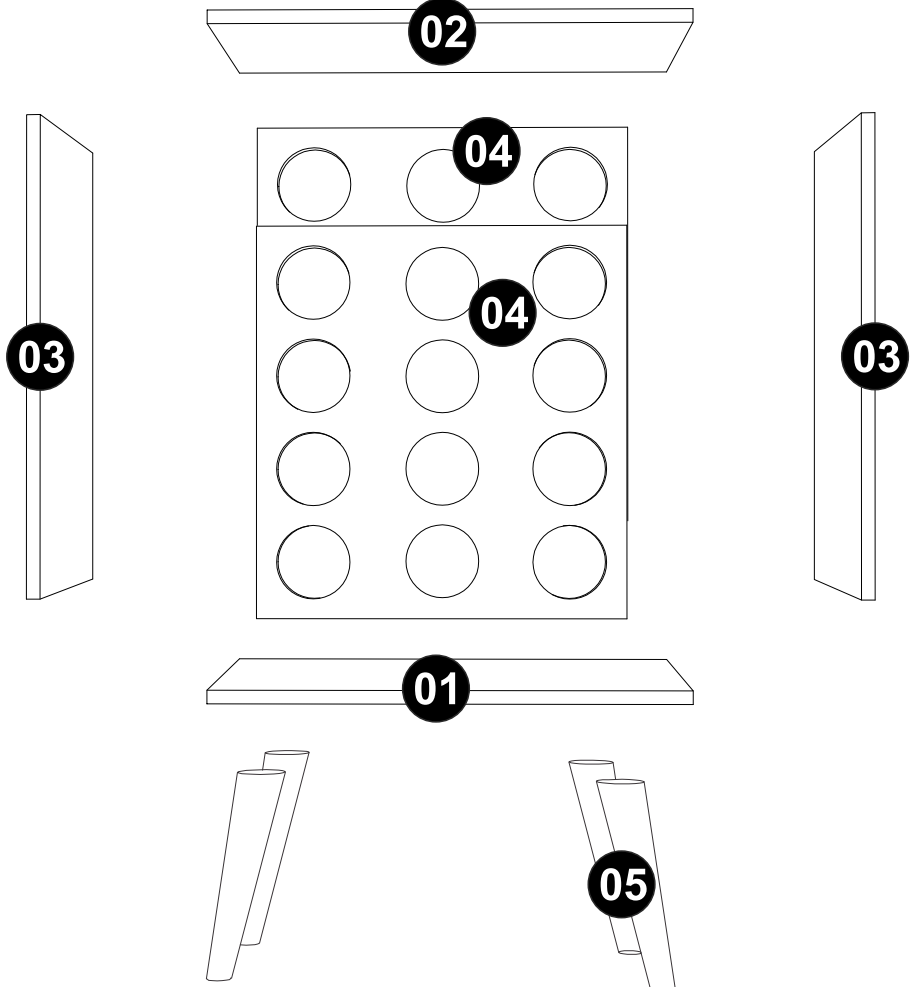

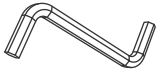

EF 000741 x 1



EF 000745 x 4



EF 000132 x 4



EF 000033 x 24

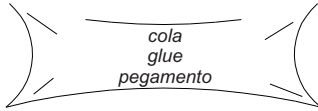

EF 000008 x 2



GIZ x 01
CHALK x 01
TIZA x 01

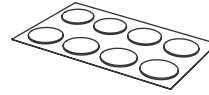

TAPA FUROS x 4
STICKER x 4
TAPAS PLÁSTICAS x 4

A = 5 KG - 11LB

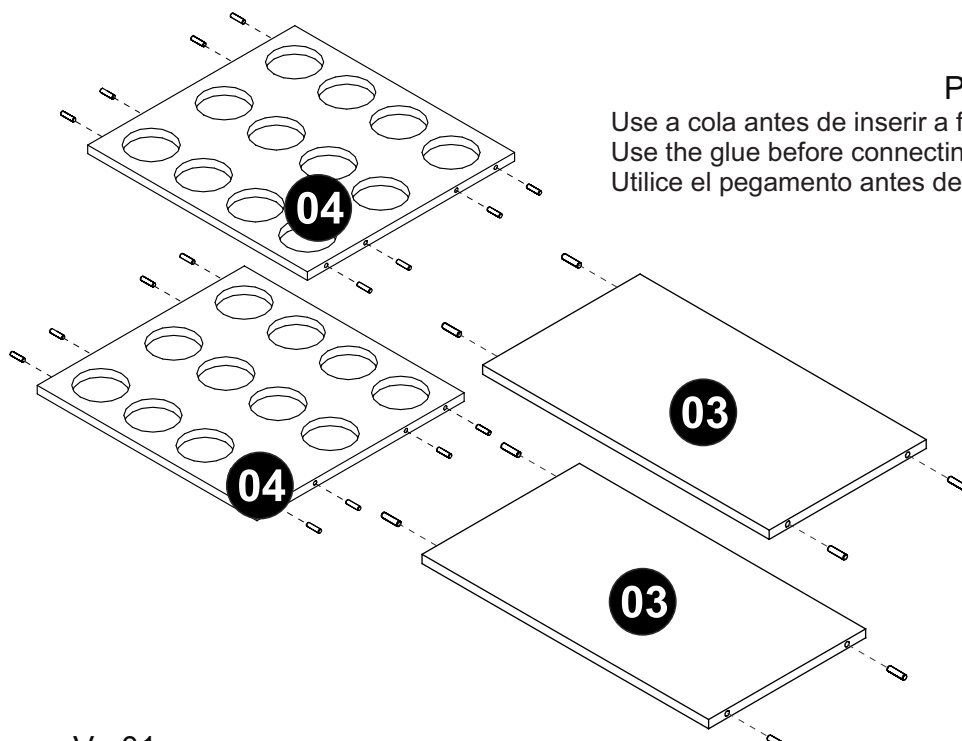
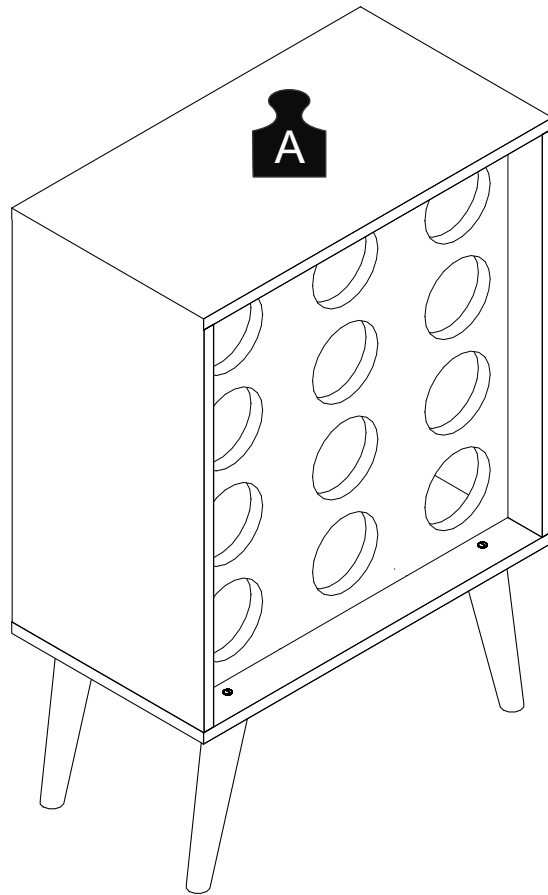

PASSO 1 / STEP 1 / PASO 1

Use a cola antes de inserir a ferragem EF 000033 nas peças 04 e 03.
Use the glue before connecting hardware EF 000033 into pieces 04 and 03.
Utilice el pegamento antes de añadir el herraje EF 000033 en las piezas 04 y 03.

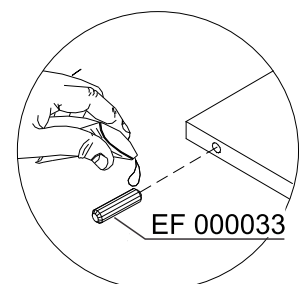

PASSO 2 / STEP 2 / PASO 2

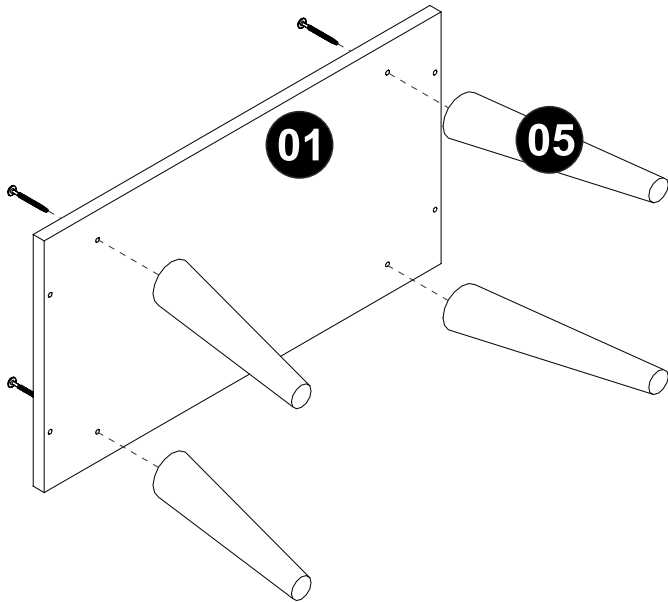

Fixe os pés (peças 05) na peça 01 usando a ferragem EF 000745 e EF 000741.
Fix the feet (pieces 05) at piece 01 using hardware EF 000745 and EF 000741.
Fije los pies (piezas 05) en la pieza 01 utilizando los herrajes EF000745 y EF 000741.

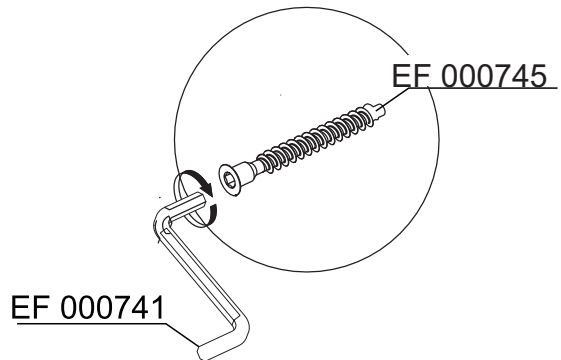

PASSO 3 / STEP 3 / PASO 3

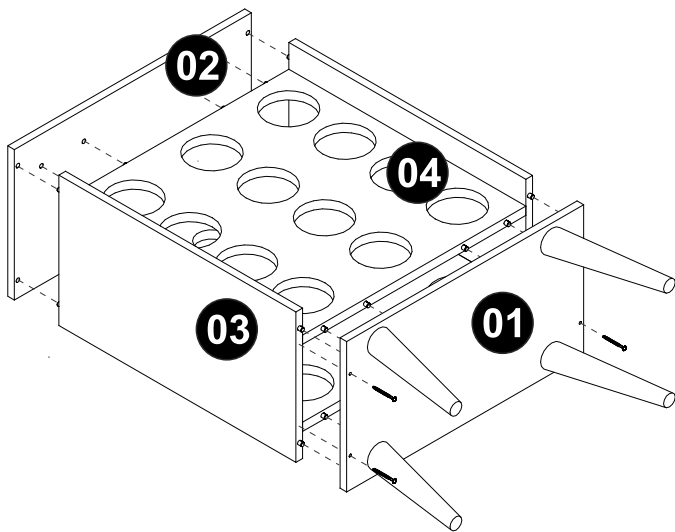

Use a cola antes de conectar as peças 03, 04 e 02. Use a ferragem EF 000132 para fixar a peça 01.
Use the glue before connecting pieces 03, 04 and 02. Use hardware EF 000132 to fix piece 01.
Utilice el pegamento antes de juntar las piezas 03, 04 y 02. Utilice el herraje EF 000132 para fijar la pieza 01.

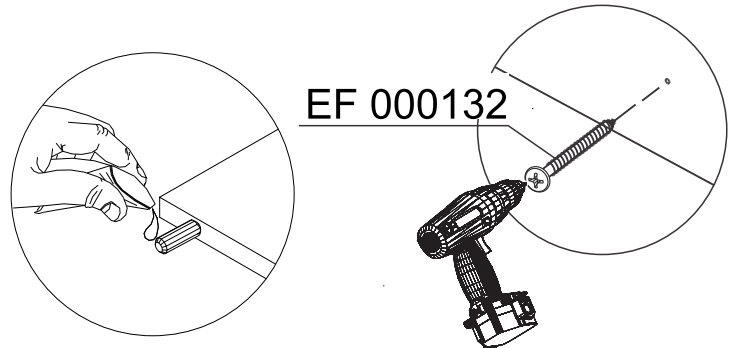

PASSO 4 / STEP 4/ PASO 4

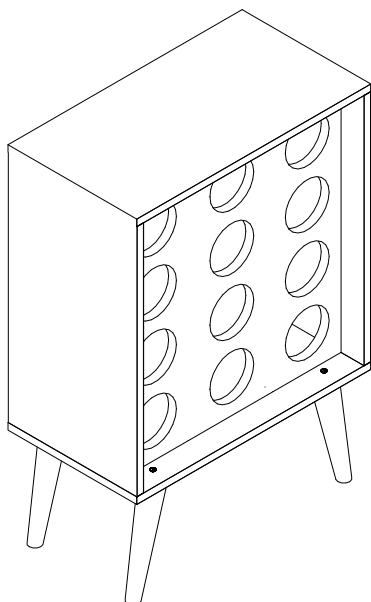

Use os tapa furos para cobrir os parafusos aparentes. Use o giz para dar o acabamento final ao produto.
Use stickers to cover apparent screws. Use the chalk to give the final finish on the product.
Utilice los tapa huecos para cubrir los tornillos aparentes. Utilice la tiza para dar el acabado final al producto.

