

ENCLO

HIDE IT WITH STYLE

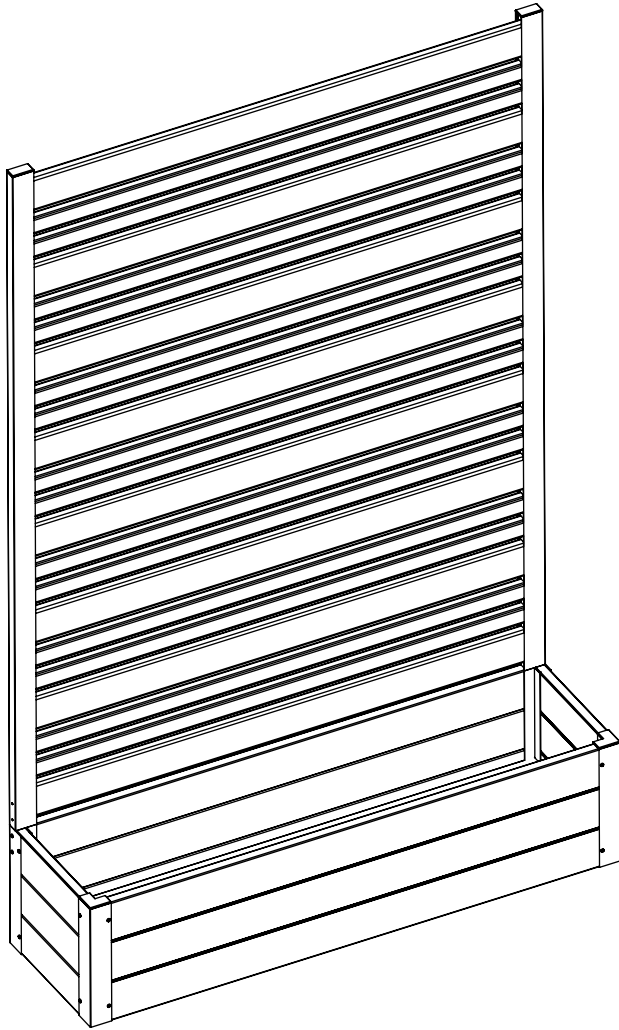

6' Florence Screen Kit w/ Planter Box

60 min
Assembly
Approximate time



Assembly Video
Scan the QR Code below



ASSEMBLY INSTRUCTIONS

EC18024 (CEDAR COLOR)

EC18025 (ASH COLOR)

www.encloscreens.com

VER. 101322

GENERAL INFORMATION



IMPORTANT

- ◀ Check the inside of the larger pieces in your box for other materials packed inside.
- ◀ When assembling components, place on a non-abrasive surface (i.e. shipping box) to avoid scratching.
- ◀ We recommend an area approximately 5'x 8' for unobstructed assembling.
- ◀ You should not need to use excessive force when assembling components.

MISSING OR DAMAGED PARTS?

VISIT OUR WEBSITE FIRST, SO WE CAN HELP YOU RIGHT AWAY!

Although great care has been taken to ensure proper packaging and handling of this product, occasionally problems occur. If you discover any missing, damaged, or defective parts, please visit our website to order replacement parts. If you experience any further trouble with your product, please contact our customer service department.

 parts.nychbrands.com

 support@encloscreens.com

 **704-892-5222 / 877-234-6196**

Customer service agents are available to take calls weekdays from 9am-5pm EST. If you call outside of business hours, please leave a voicemail.

To help you quickly and accurately, please have reference item number **EC18024/ EC18025** and the specific part name which can be found on page 5. It is helpful if you can provide the batch lot which is a stamped number on the end of the box.

NEED ASSEMBLY HELP?

If you are having problems with the assembly or installation of this product, we are happy to assist you with the process, **so please give us a call at 704-892-5222 / 877-304-3263**

NEED TO RETURN?

If for some reason you need to return this product, please allow us to help resolve your issues first. If you still decide to return the product, **you will need to initiate the return from the company you originally purchased from.**

DETAILED PRODUCT DIMENSIONS & SPECIFICATIONS



Note: For best plant growth, it is recommended to drill (2) $\frac{3}{4}$ " diameter drainage holes in the floor board roughly 12" apart.

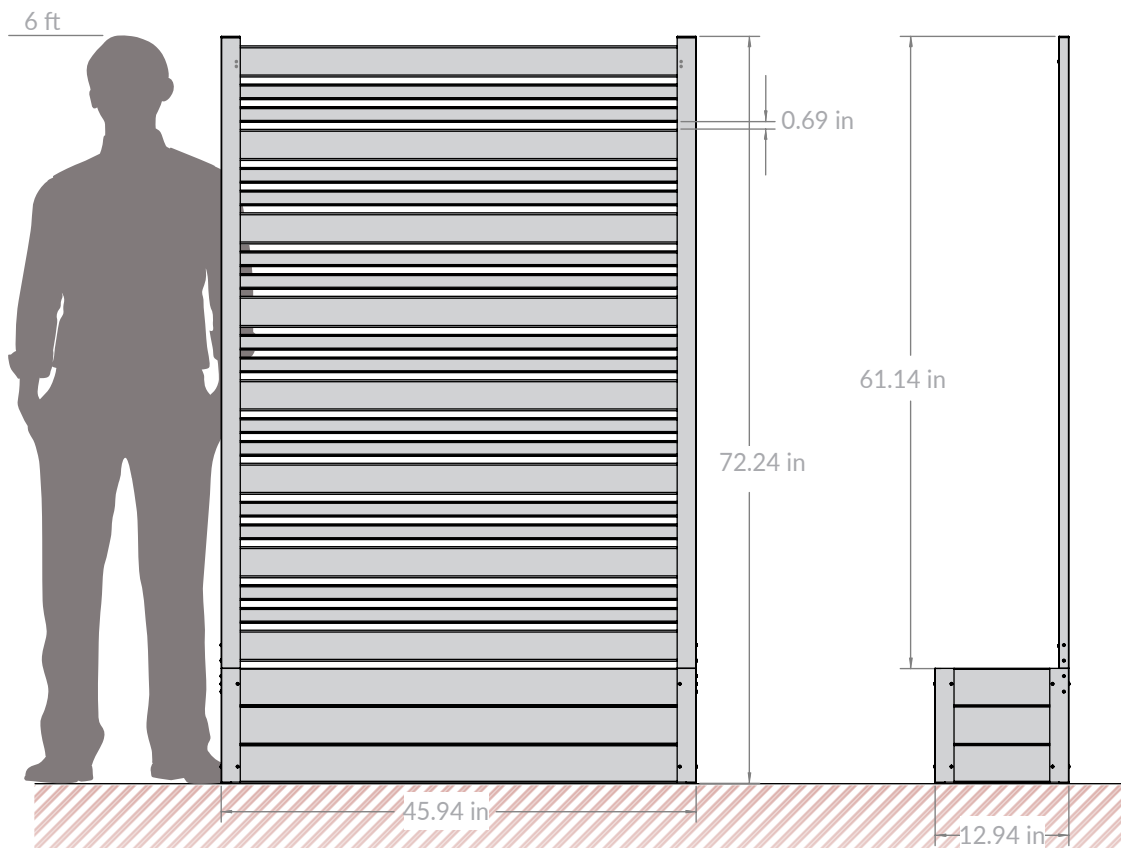
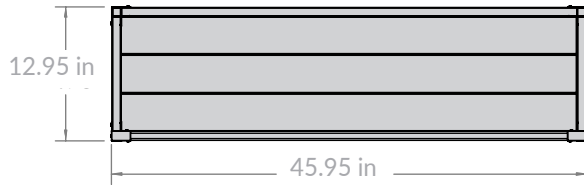

Planter Box Depth: 8.3"

Planter Box Volume: 2.33 cubic ft (70 qts)

LAY OUT TOOLS

*- Tools required for a smoother installation experience.

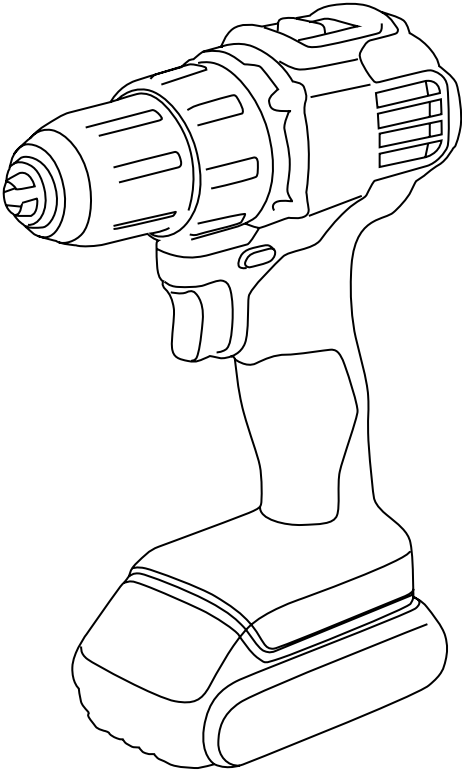

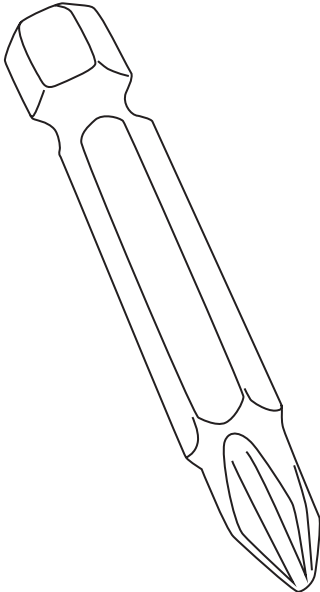

▶ Drill



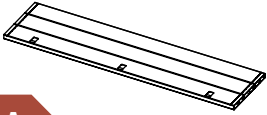
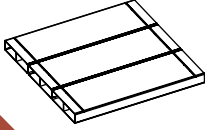
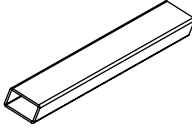

▶ Phillips Screwdriver Bit

LAY OUT MATERIALS

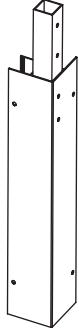
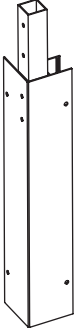
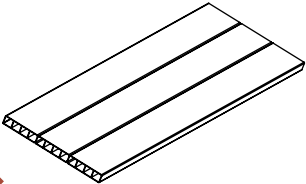

PLANTER BOX

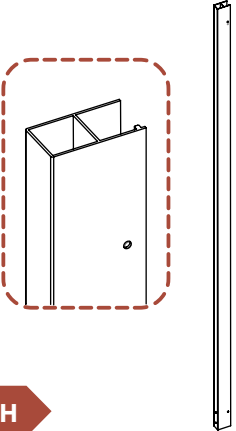
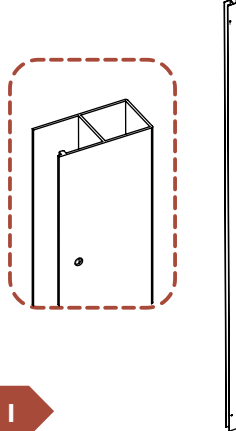
 <p>A Planter Long Board (2) 7/8" x 11" x 44"</p>	 <p>B Planter Short Board (2) 7/8" x 11" x 11"</p>	 <p>C Floor Supports (3) 7/8" x 1 1/2" x 12 3/4"</p>	 <p>D Front Post (2) 1 7/8" x 1 7/8" x 11"</p>
 <p>E Back Left Post (1) 1 7/8" x 1 7/8" x 11"</p>	 <p>F Back Right Post (1) 1 7/8" x 1 7/8" x 11"</p>	 <p>G Floor (1) 7/8" x 11" x 44"</p>	

SCREEN

 <p>H Left Post - Long (1) 1" x 1 7/8" x 61"</p>	 <p>I Right Post - Long (1) 1" x 1 7/8" x 61"</p>	 <p>J Wide Board (8) 7/8" x 3" x 44"</p>	 <p>K Narrow Board (14) 7/8" x 1 1/2" x 44"</p>
---	--	---	--

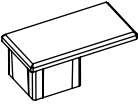
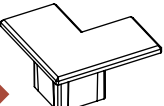
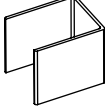
HARDWARE

 <p>L Top Post Cap (2)</p>	 <p>M Corner Post Cap (2)</p>	 <p>N Spacer (44)</p>	 <p>O 3/4" Self-Drilling Stainless Steel Screw (28)</p>
---	--	---	--

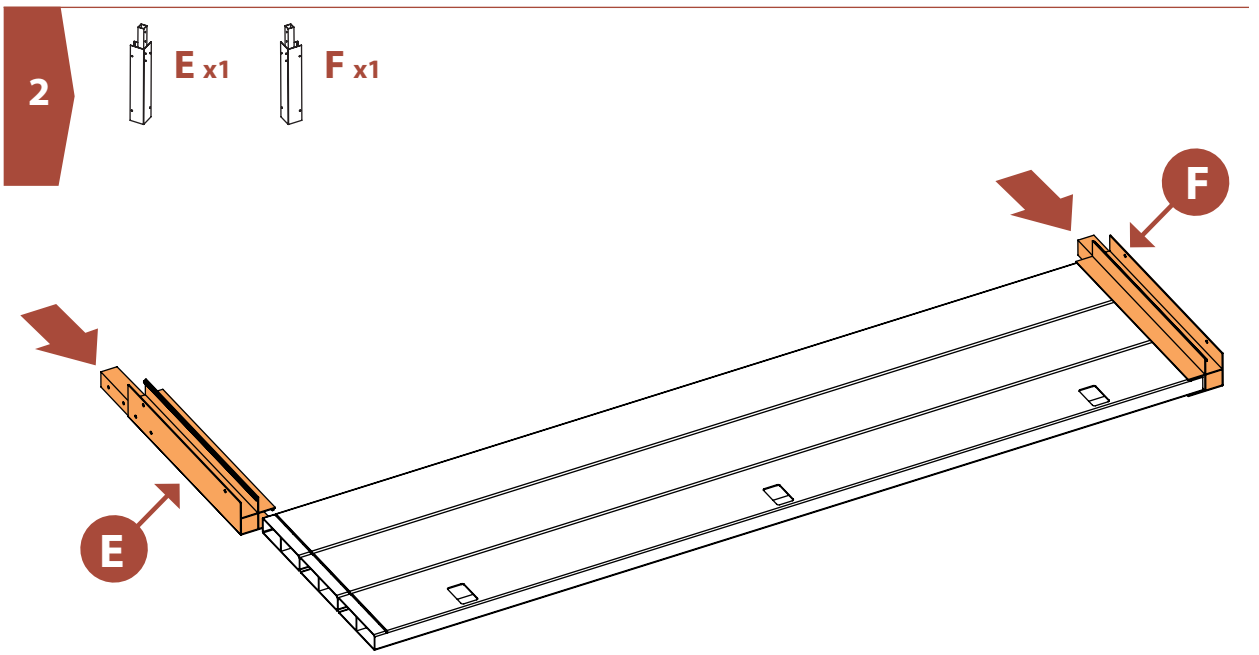
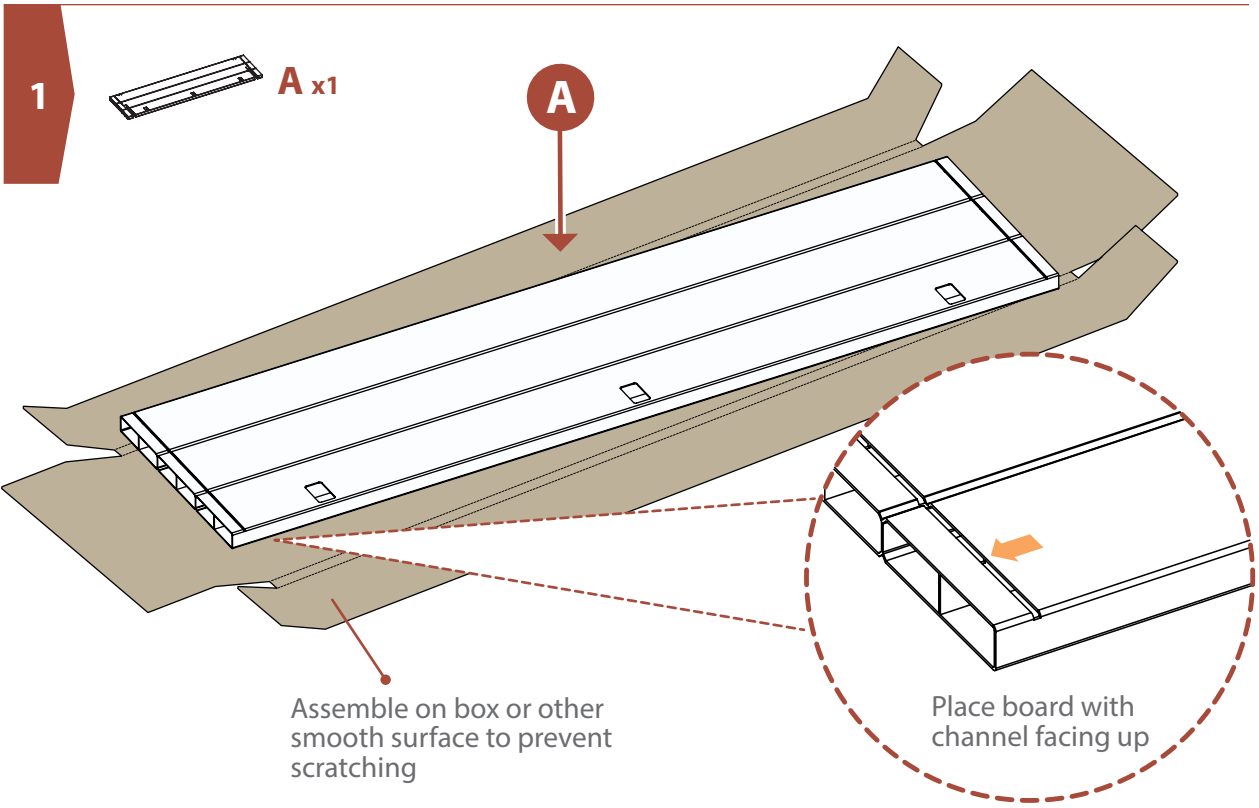

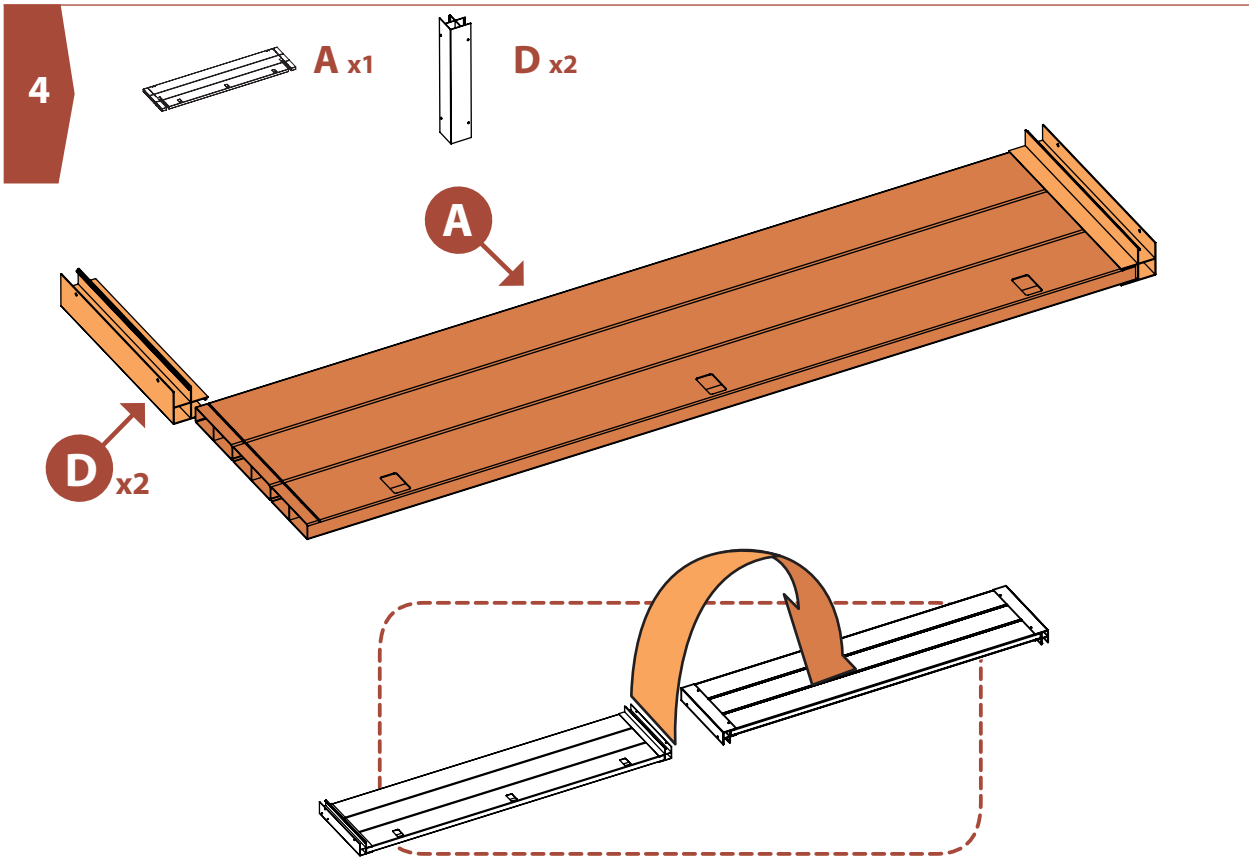
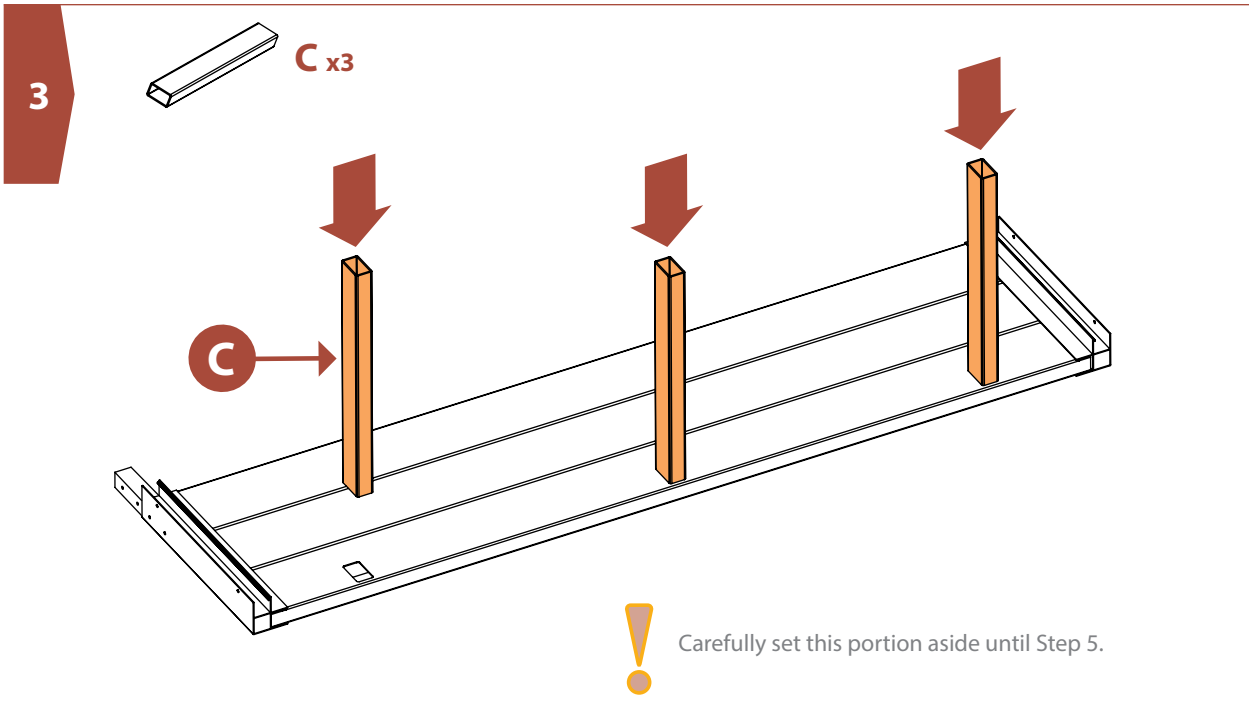

5

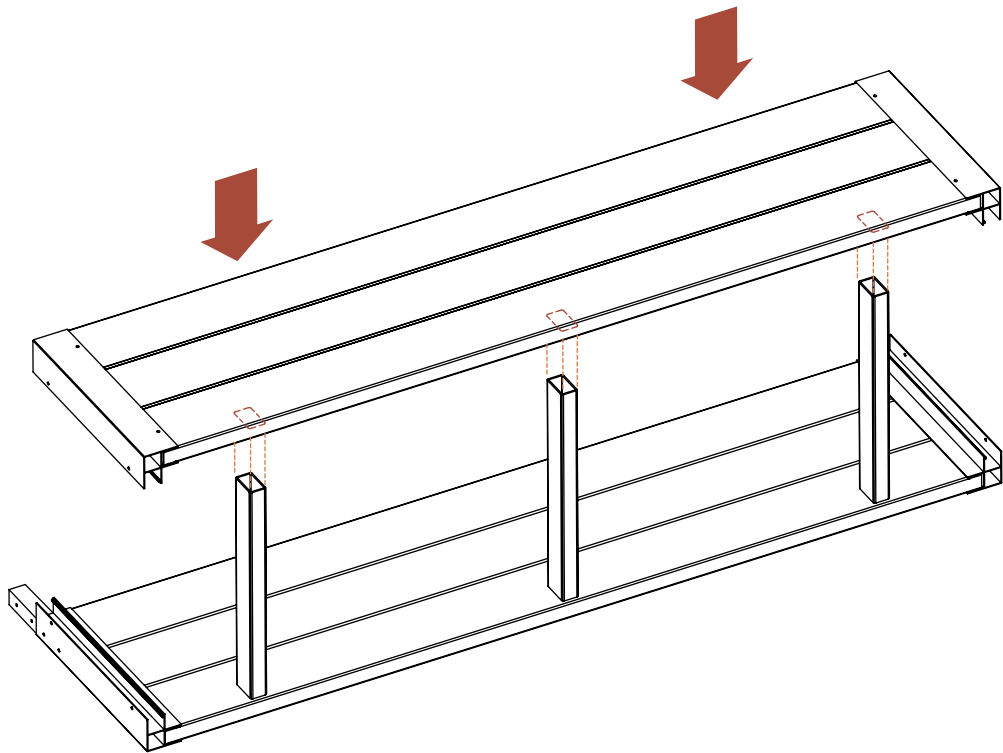

6

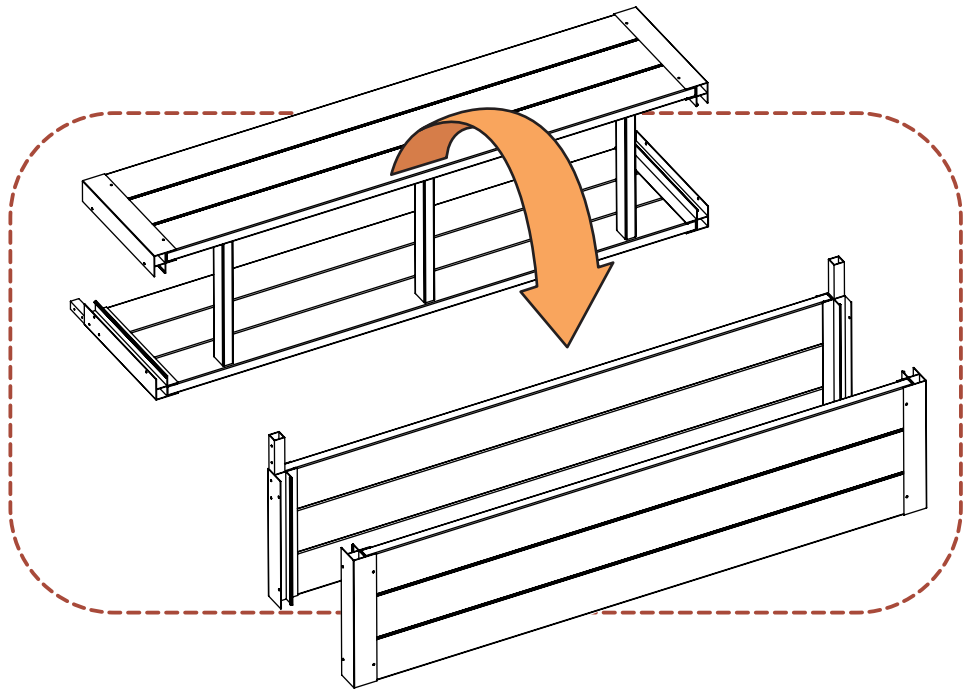

7

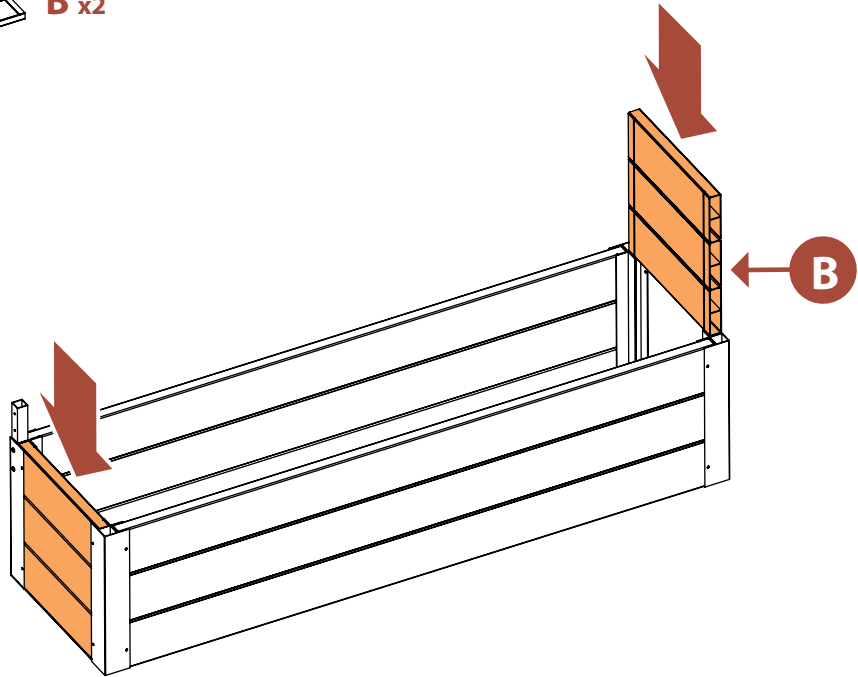
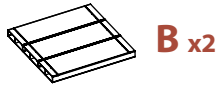

8

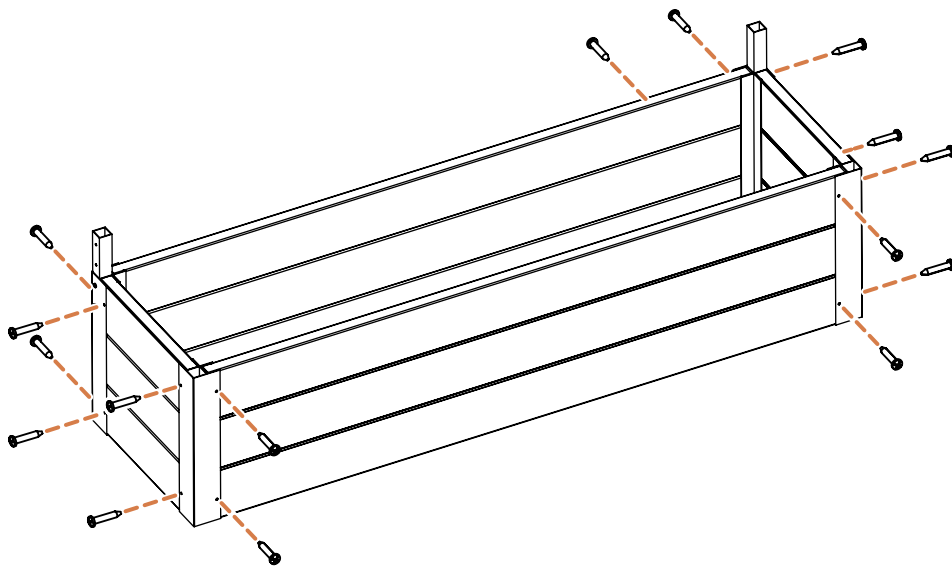
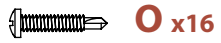

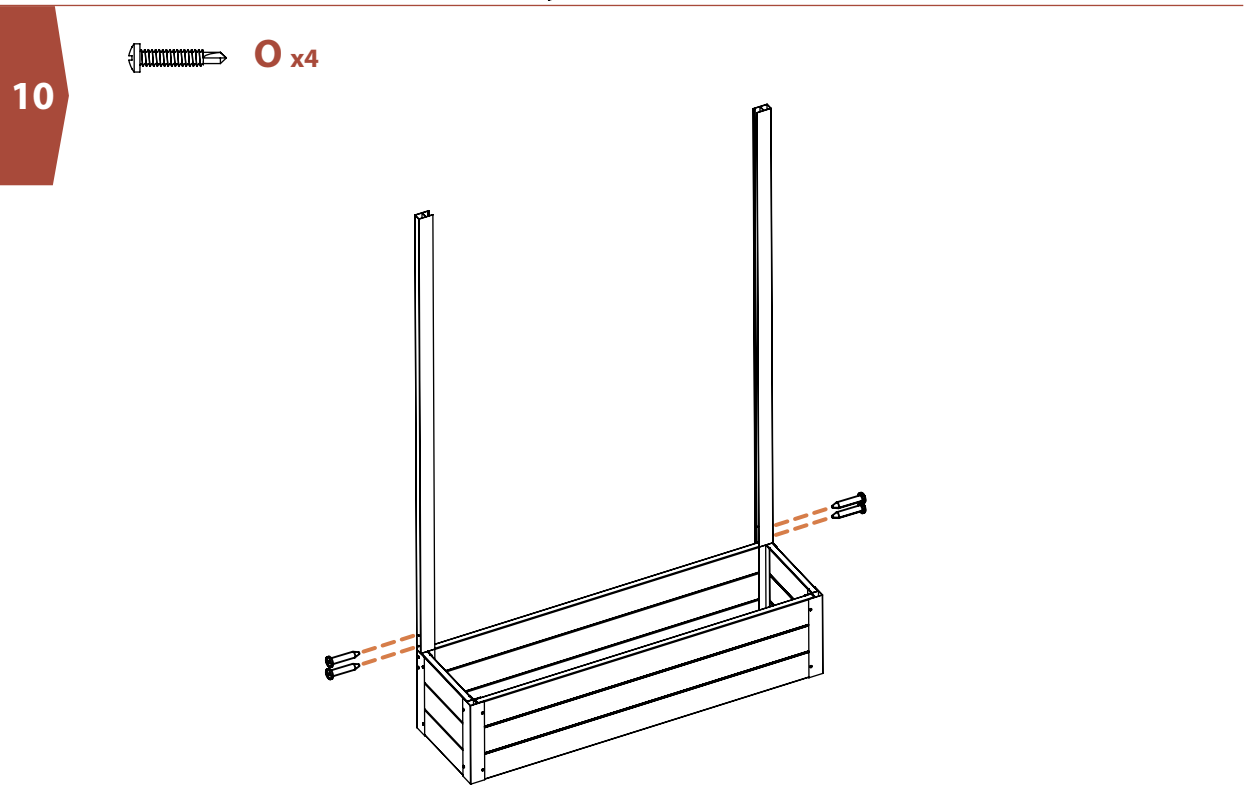
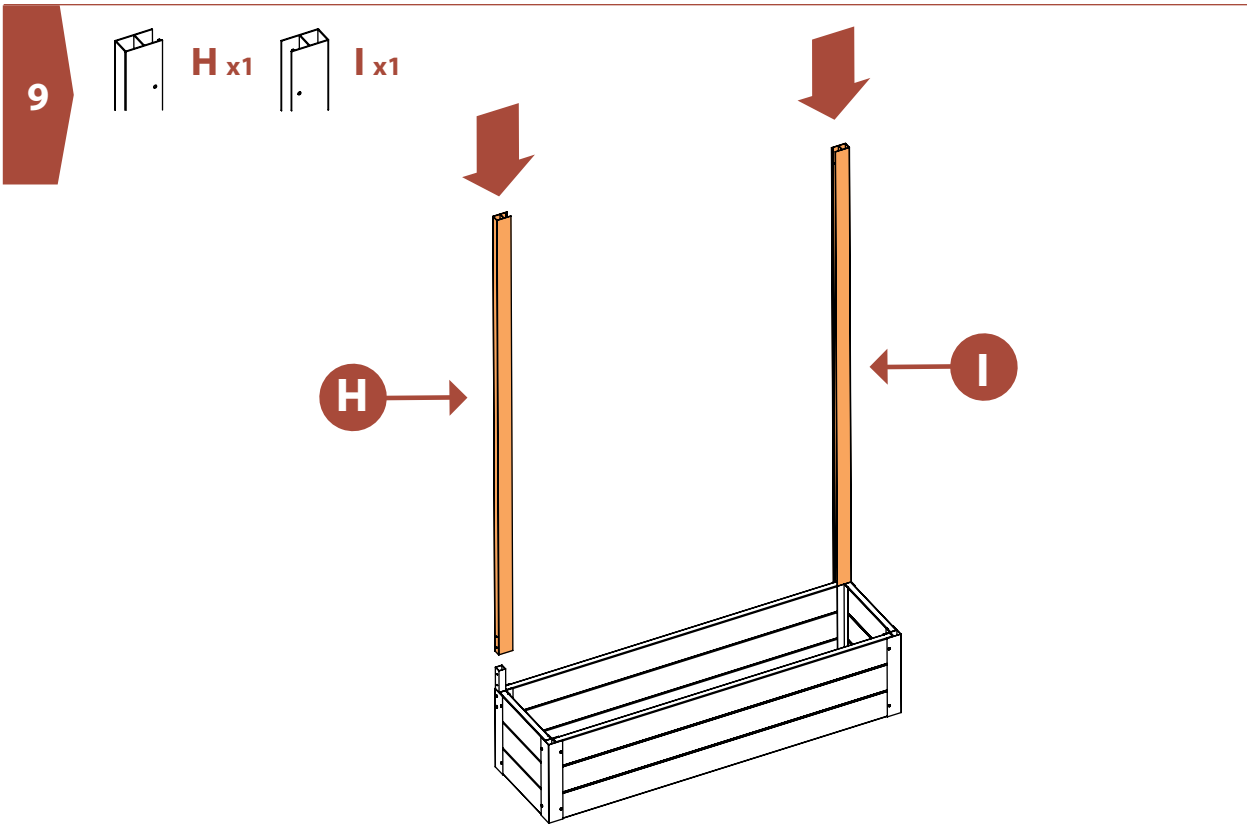

 **J** x1  **N** x2

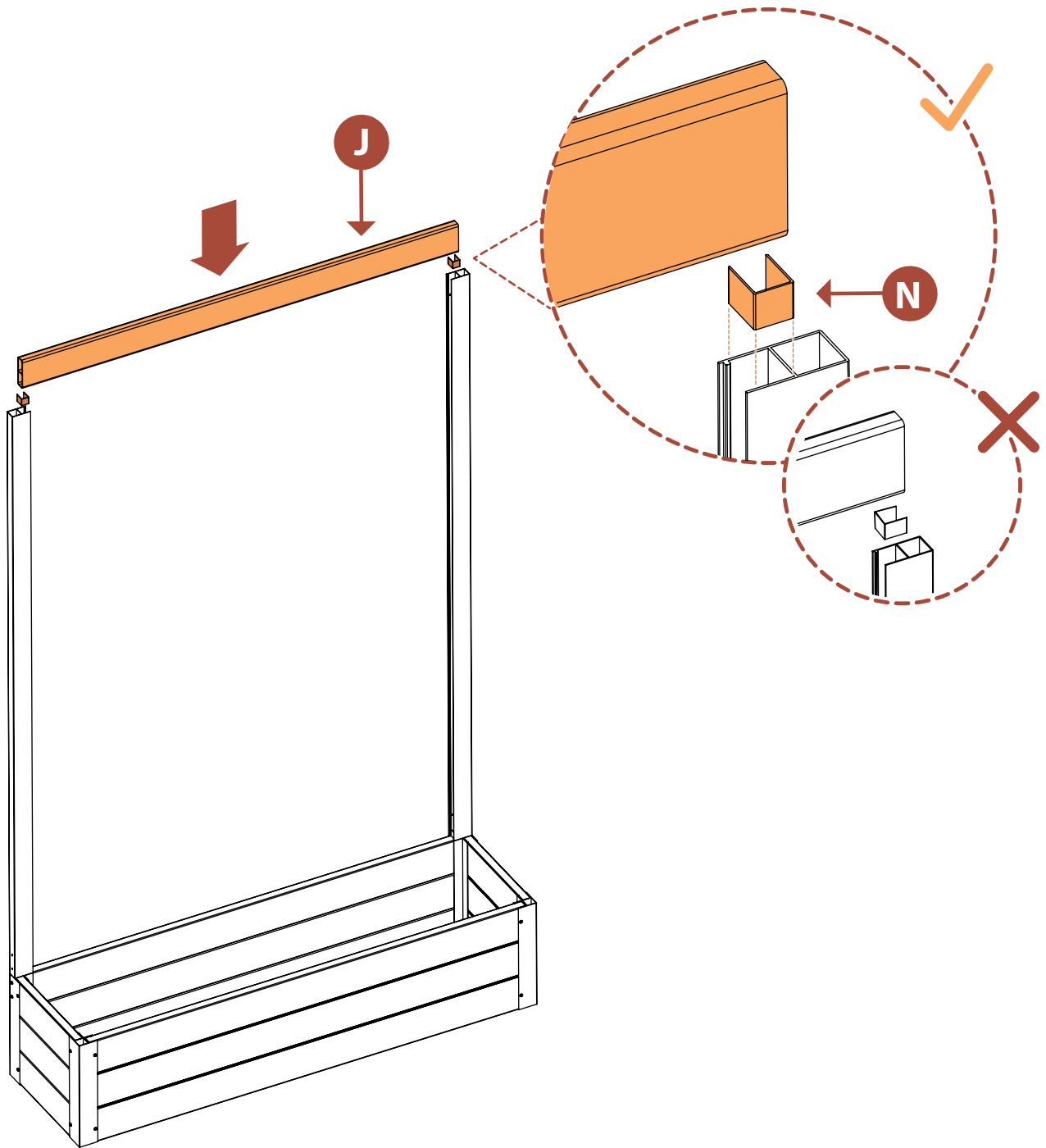

12



Repeat step 11,
following the pattern
shown below

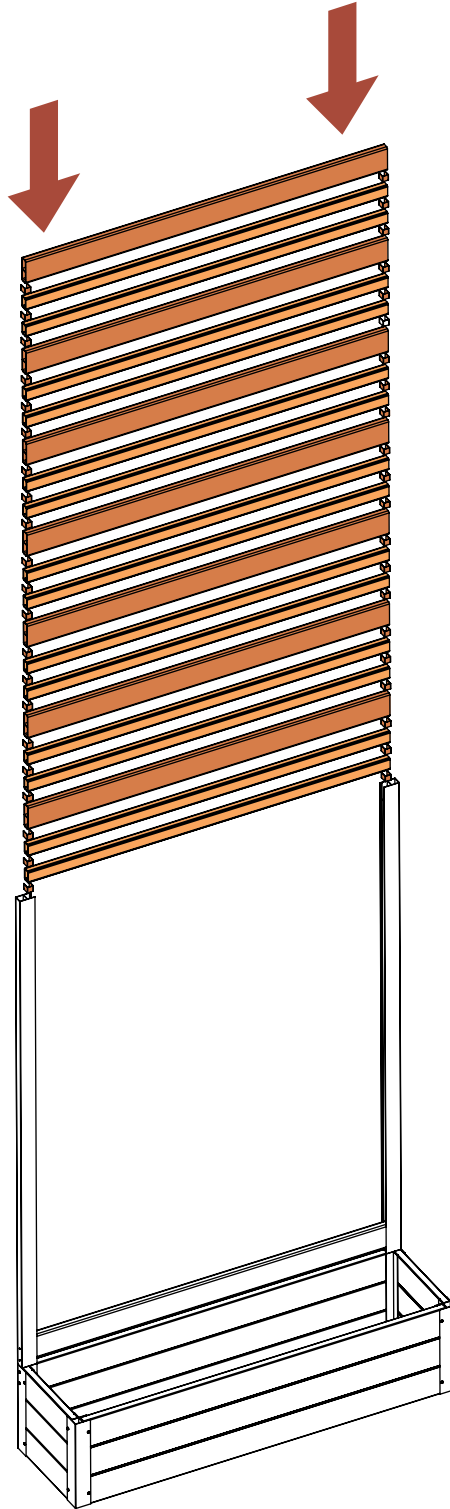

13

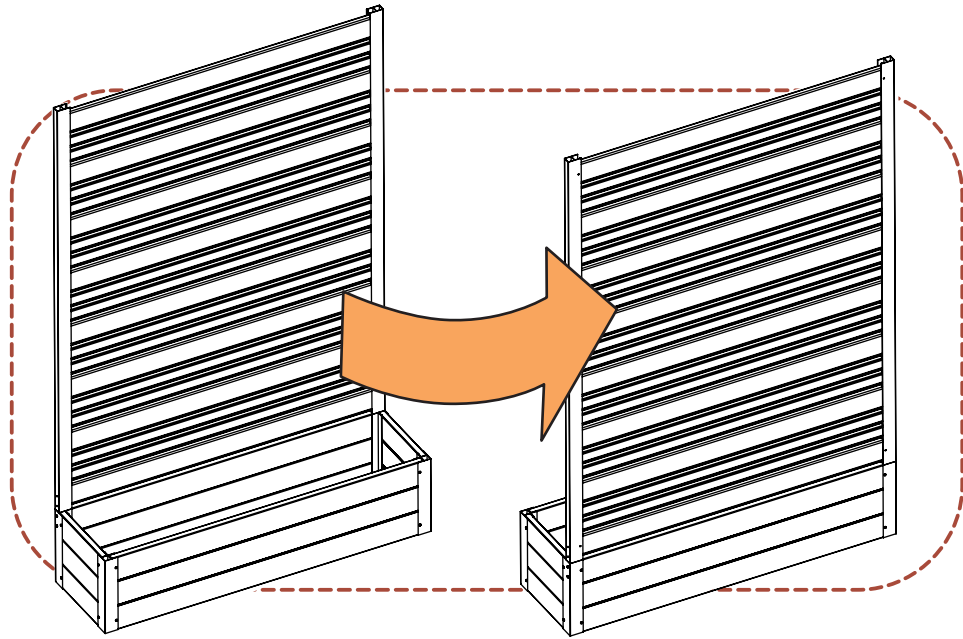

14

 **O x4**

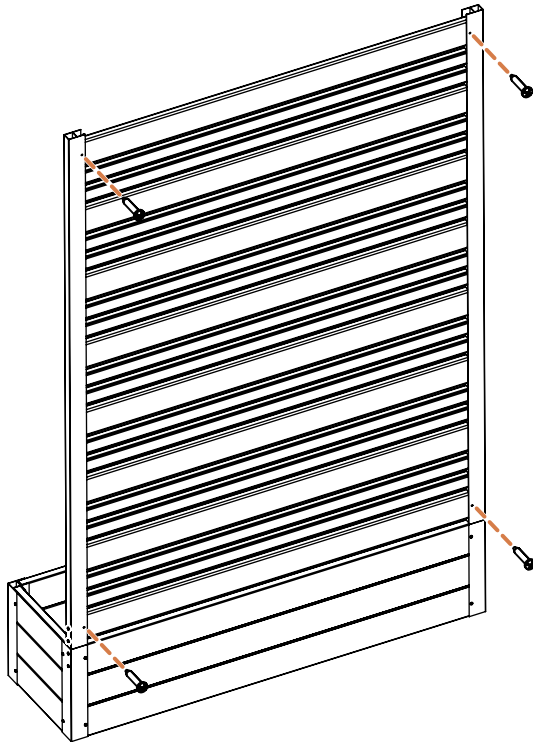

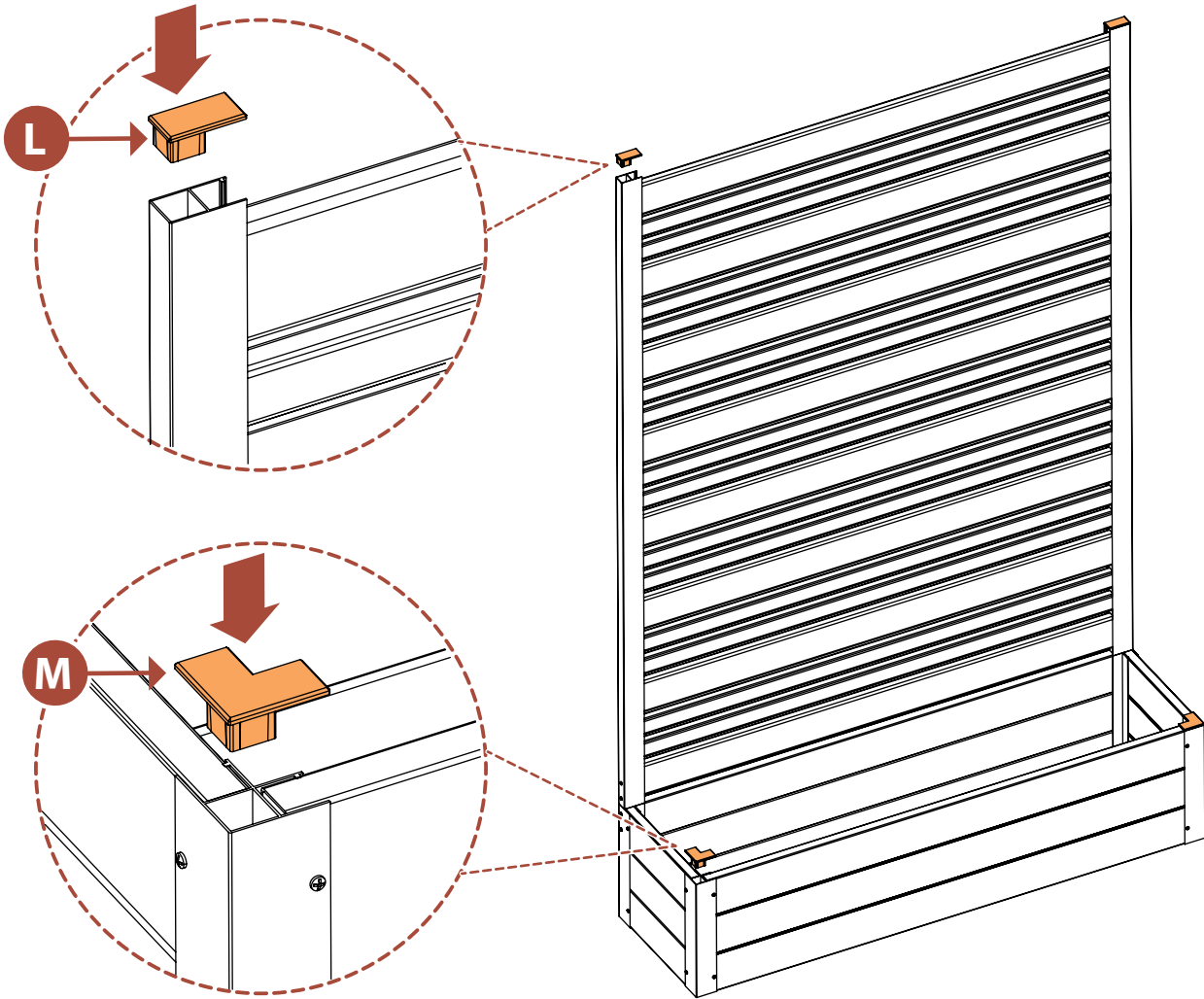
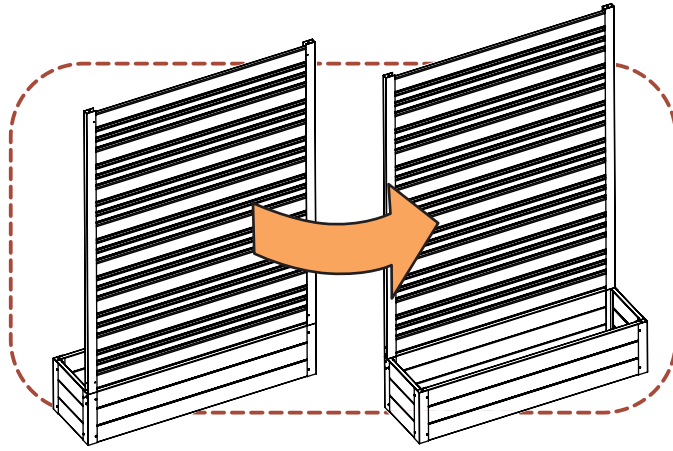

16



Note: For best plant growth, it is recommended to drill (2) 3/4" diameter drainage holes in part (G) roughly 12" apart.

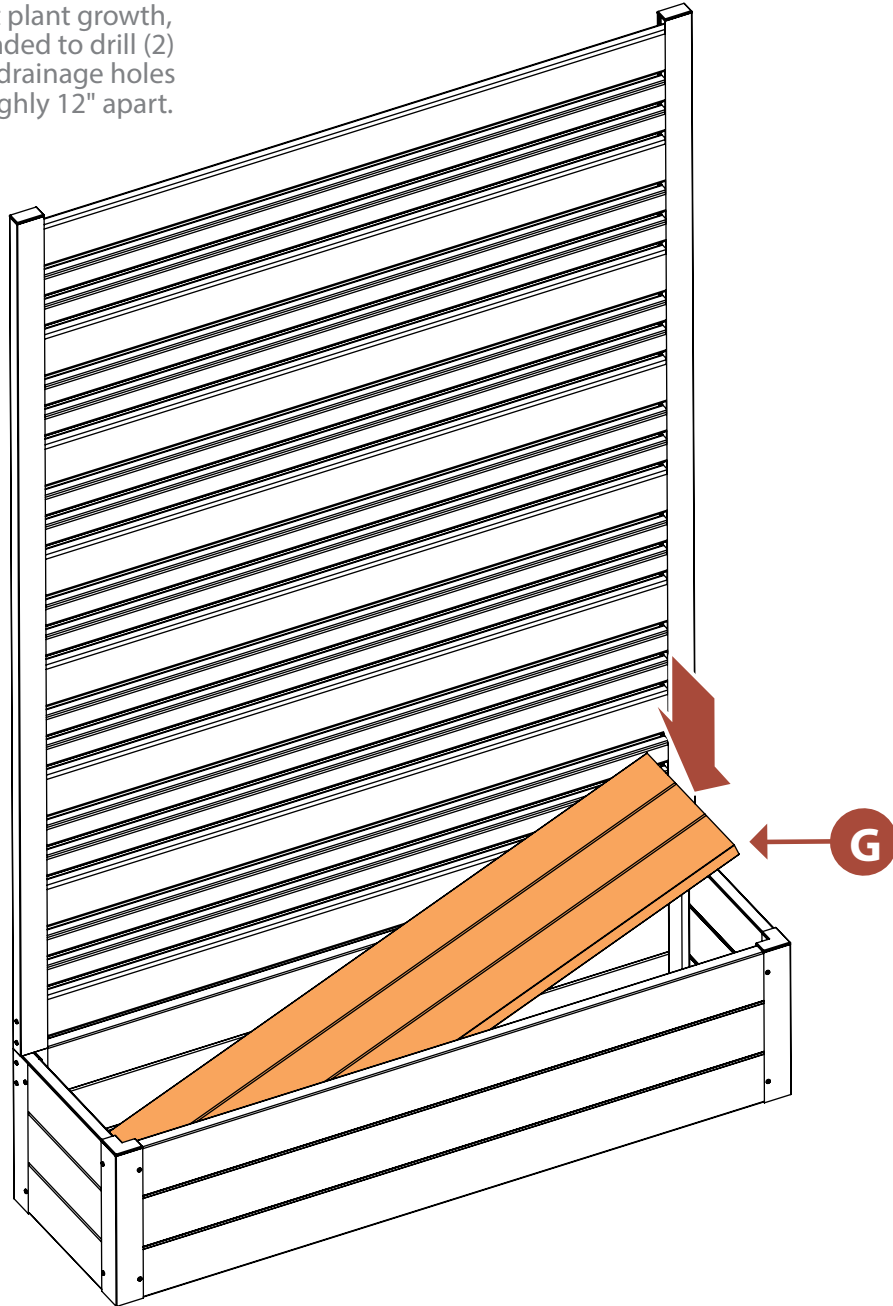

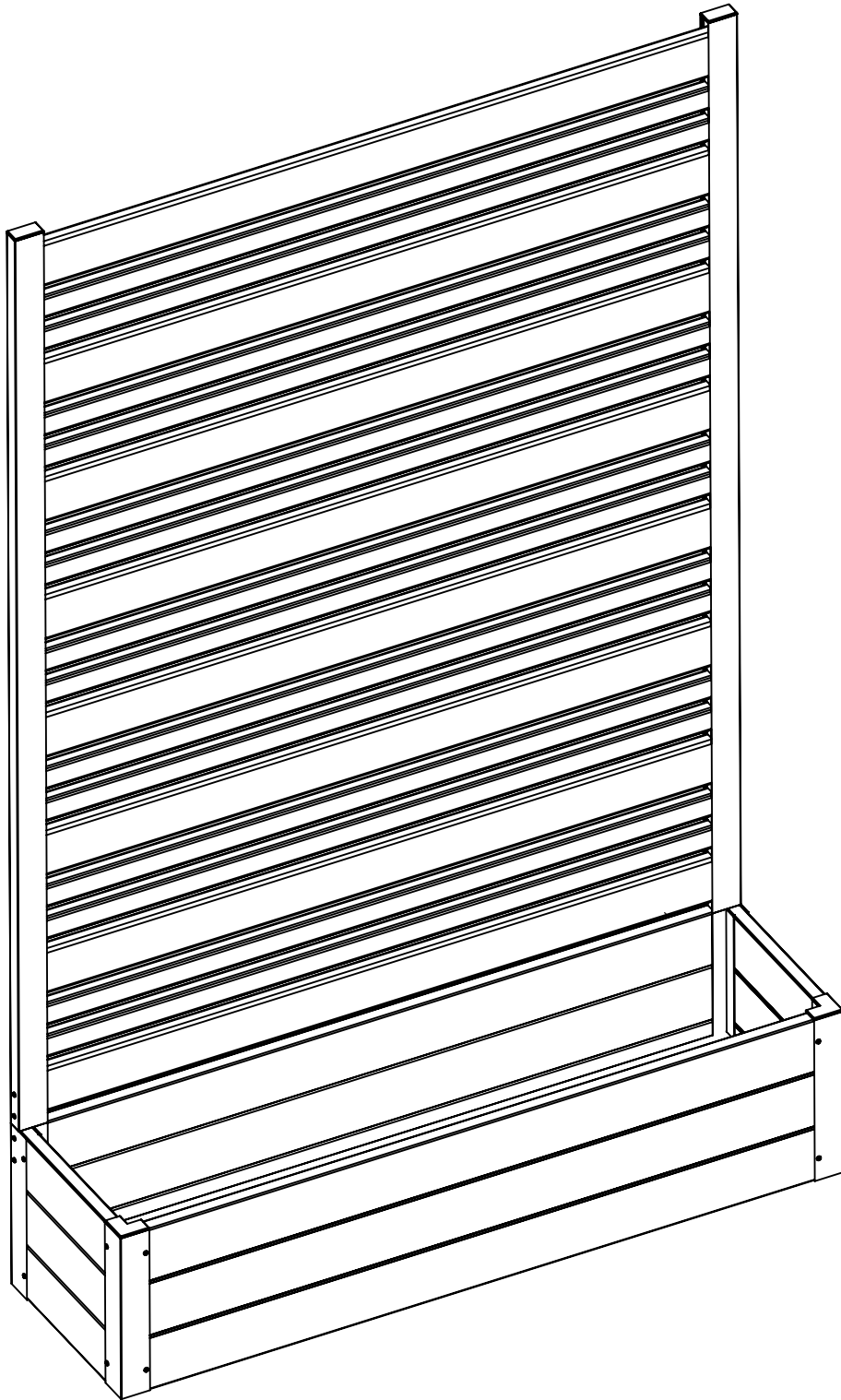

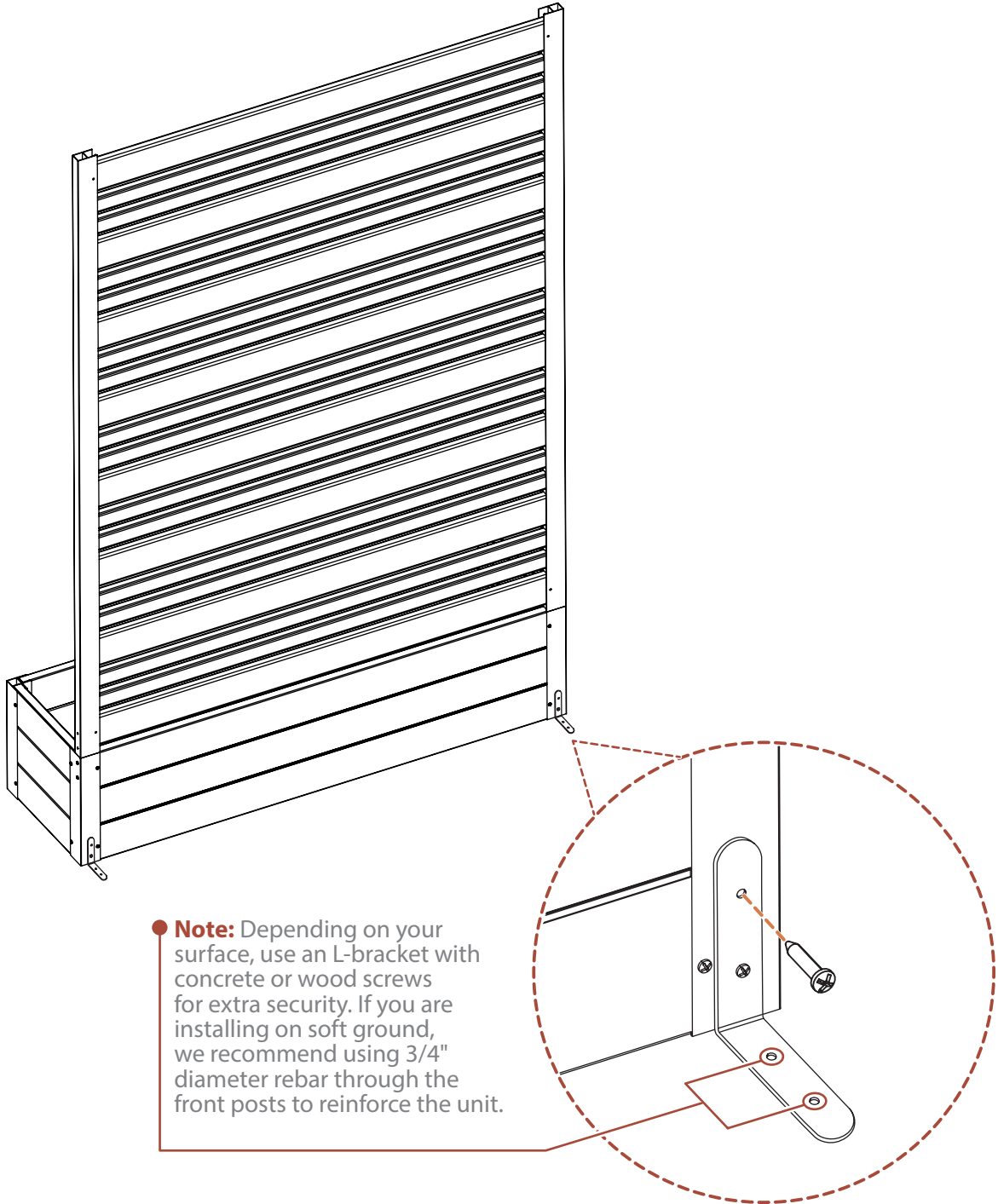

ENCLO

HIDE IT WITH STYLE

www.encloscreens.com

support@encloscreens.com



704-892-5222
877-234-6196



6935 Reames Rd. Ste. K.
Charlotte, NC 28216



ASSEMBLY INSTRUCTIONS

EC18024 (CEDAR COLOR)

EC18025 (ASH COLOR)