

Model 6649 - LED Shop Light



Notes:

1. The lamp should be installed in a minimum distance of 18 inches from any combustible material, to prevent the occurrence of fire hazard
 2. Key parts of the heating will cause burns
 3. Use a clean cloth or gloves when installing.
- Technical specification

---LED driver: 1 00-240 V ~ 60Hz, 40W , 0.4-0.3A
 Light source: LED (0.156w*256pcs leds)
 Power: 40w
 Maintenance:
 Disconnect the power supply, clean the fixture and accessories.
 Inspect the drive inside and keep it dry
 Regular connection

Installation steps

Accessories

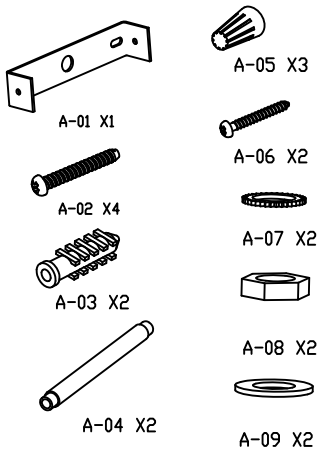

1 Cable Mount Installation

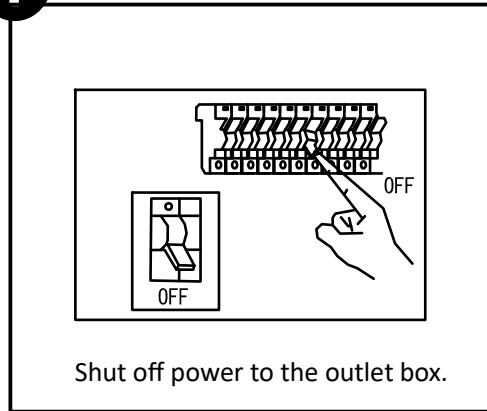

2 Ceiling Mount Installation

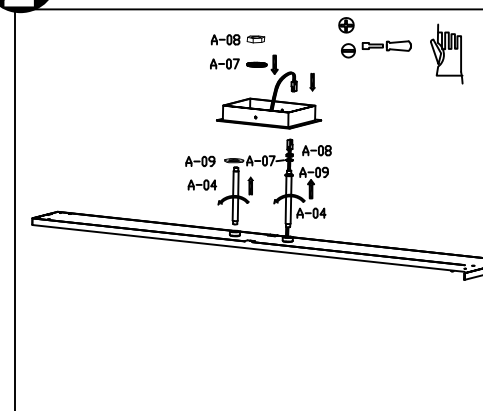

3 Ceiling Mount Installation

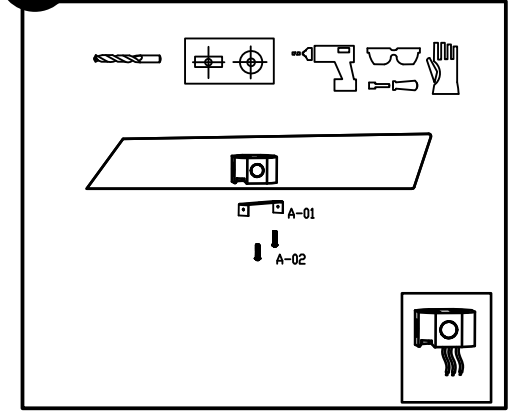

Circuit diagram

LED DE 40 W (0.156W x 256)

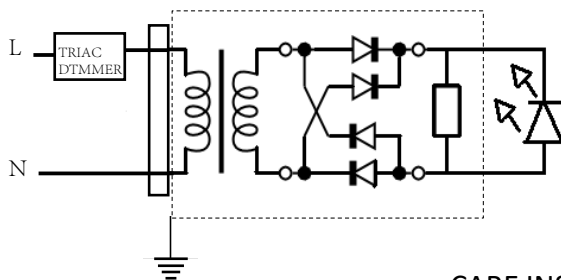

CARE INSTRUCTIONS

- Dusting — Use a clean, dry cloth.
 Cleaning — To protect the finish, avoid any harsh abrasives or chemicals.

4 Connecting the lights

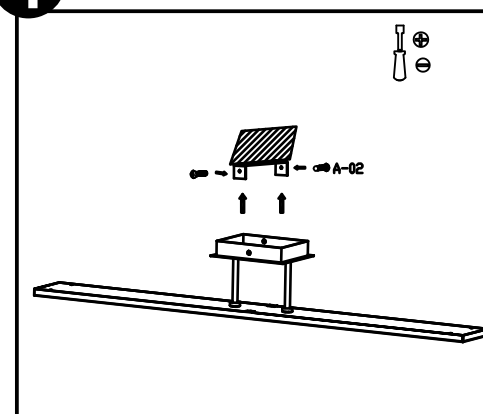

A Connecting the lights

