

BUTLER

Assembly Instructions
Style Number 2110XXX

SPECIALTY COMPANY
8200 SOUTH CHICAGO AVE., CHICAGO, IL 60617

PACKAGED

- (A) 8- Bolt $\text{Ø}5/16" \times 1-1/2"$
- (C) 8-Lock Washer $\text{Ø}5/16"$
- (D) 8-Flat Washer $\text{Ø}5/16" \times \text{Dia}16\text{mm}$
- (F) 8- Bolt $\text{Ø}1/4" \times 5/8"$
- (G) 8-Lock Washer $\text{Ø}1/4"$
- (H) 8-Flat Washer $\text{Ø}1/4" \times \text{Dia}16\text{mm}$
- (E) 4-"L" Bracket



2

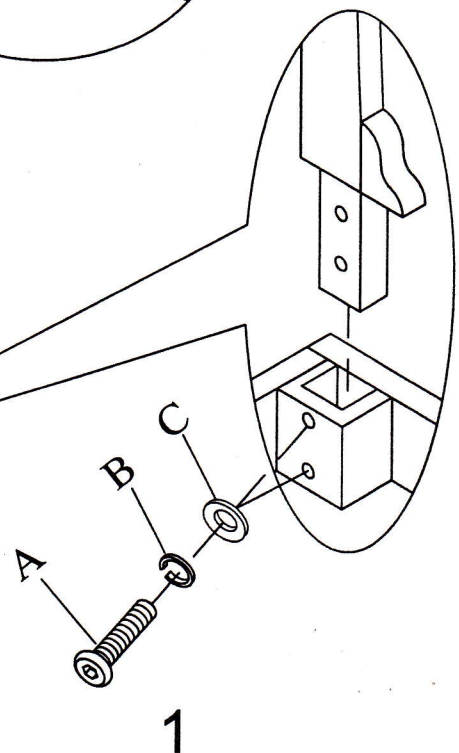
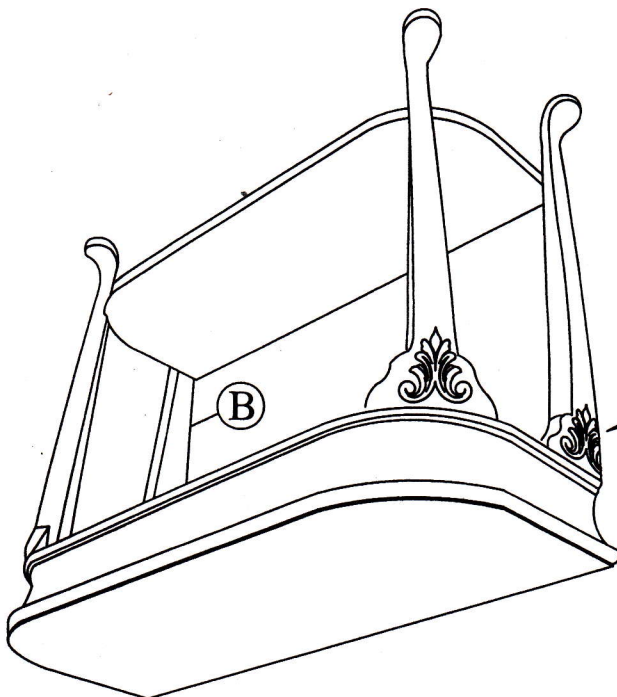
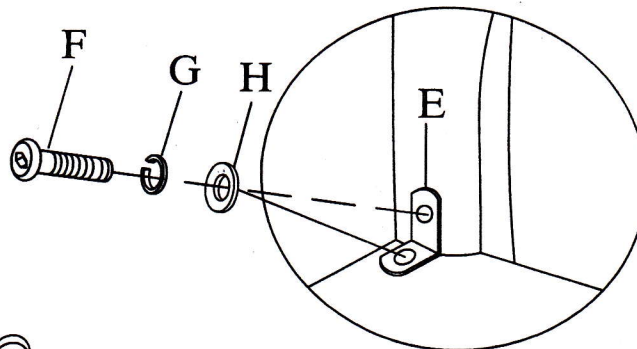

(*Caution:DO NOT OVERTIGHTEN

In any correspondence regarding this product, please include the complete Butler identification number located on the underside of the product.

We this Console Table will be a useful and decorative addition to your home for years to come.