

CARE AND MAINTENANCE

Always use felt pads under all articles to prevent discoloration or softening of the lacquer. Plastic and rubber bases on items can discolor wood. Wipe up spills immediately and avoid common hazards such as hot dishes, harsh solvents and abrasives. Cleaning should be done with a soft lint free cotton cloth dampened with water or furniture polish. On highly used surfaces we recommend applying a quality paste wax which should be used on a regular basis to provide additional protection from scratches and spills. How often you apply the wax depends on how much wear the furniture receives.

NOTICE

- * Please make sure that you have all parts indicated before you begin assembly of this item
- * This item should be assembled on a soft surface to prevent scratching the finish during assembly
- * This item may require periodic tightening



Model# : VNN1026A

Product Dimensions: D29.53xH14.57 inches

Part List and Hardware List

PIECE	DESCRIPTION	PICTURE	QUANTITY
A	CEMENT TOP		1X
B	Wooden legs		2X
C	Steel bar		4X
H1	WASHER		4x
H2	angle bolt and cylinder nut		8X
H3	BOLT M8x60		1X
H4	BOLT M8x20		4X
H5	ALLEN KEY		1X

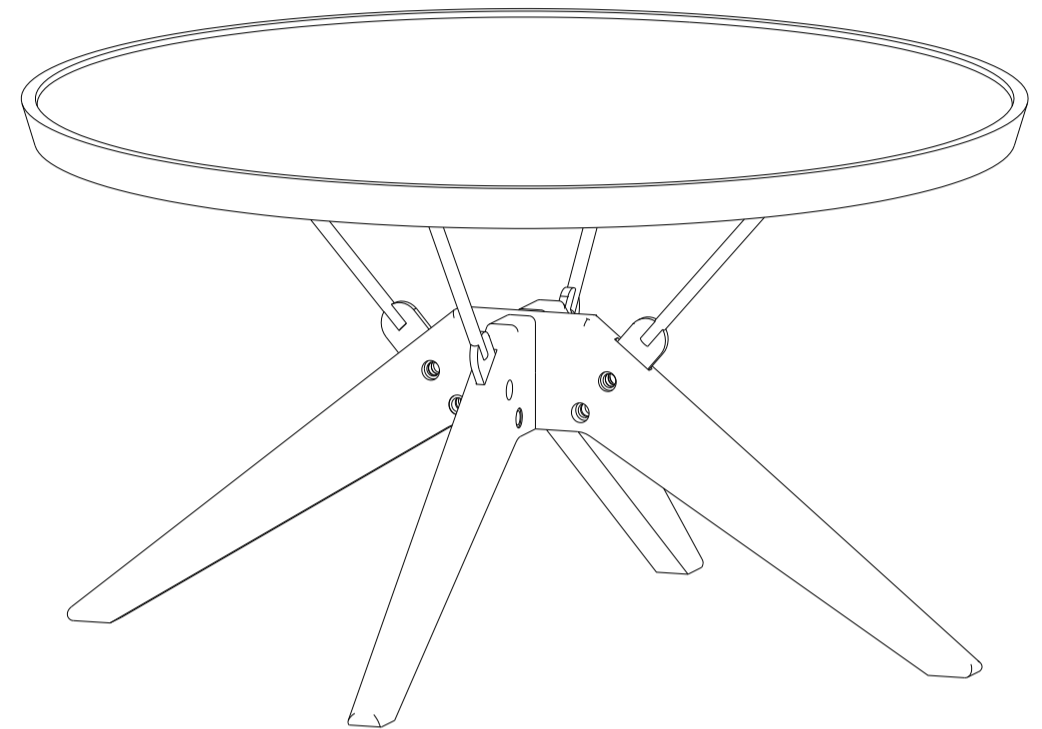

PREPARATION

Before beginning assembly of product, make sure all parts are present. Compare parts with package contents list and hardware contents list. If any part is missing or damaged, do not attempt to assemble the product. Estimated Assembly Time: 10 minutes.

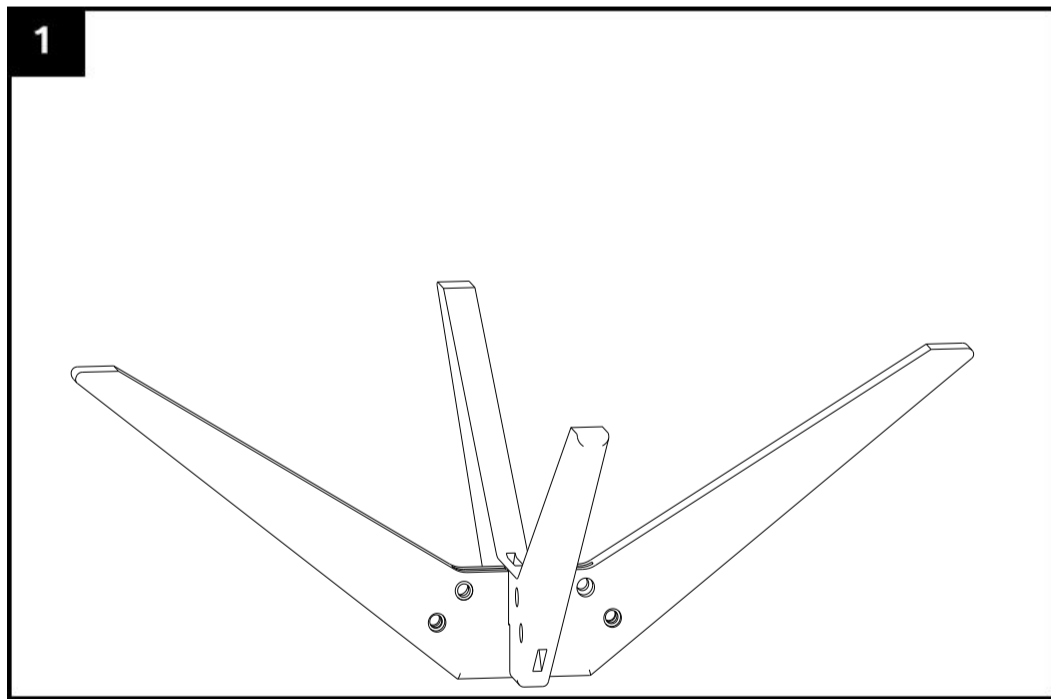

Step 1 : Use 1 bolt M8x60 (H3) to connect 2 wooden legs

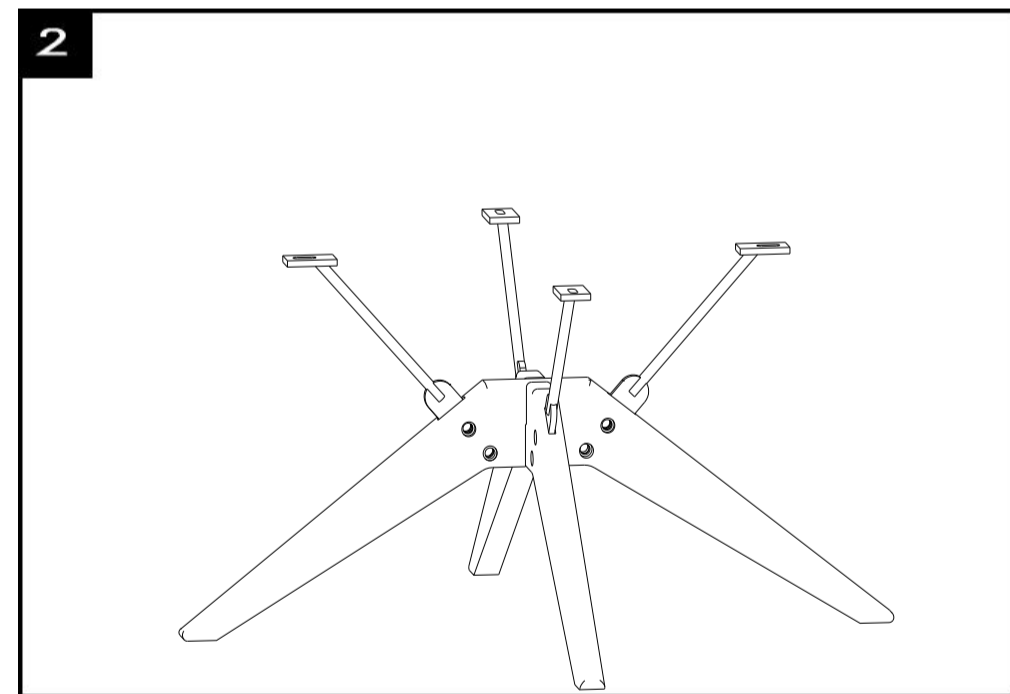

Step 2 : the hardware need to connect 4 steel bar with wooden legs are 8 bolts and nut (H2)

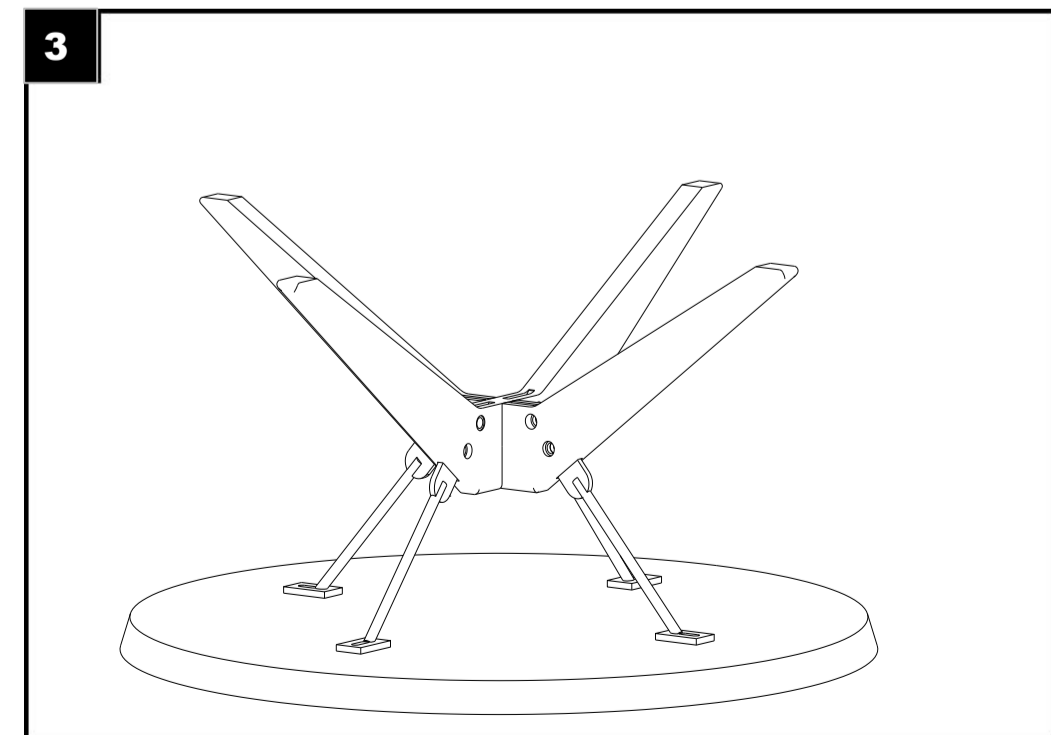

Step 3 : Use 4 bolt M8x20 (H5) and washer (H1)to fix concrete top and steel bar

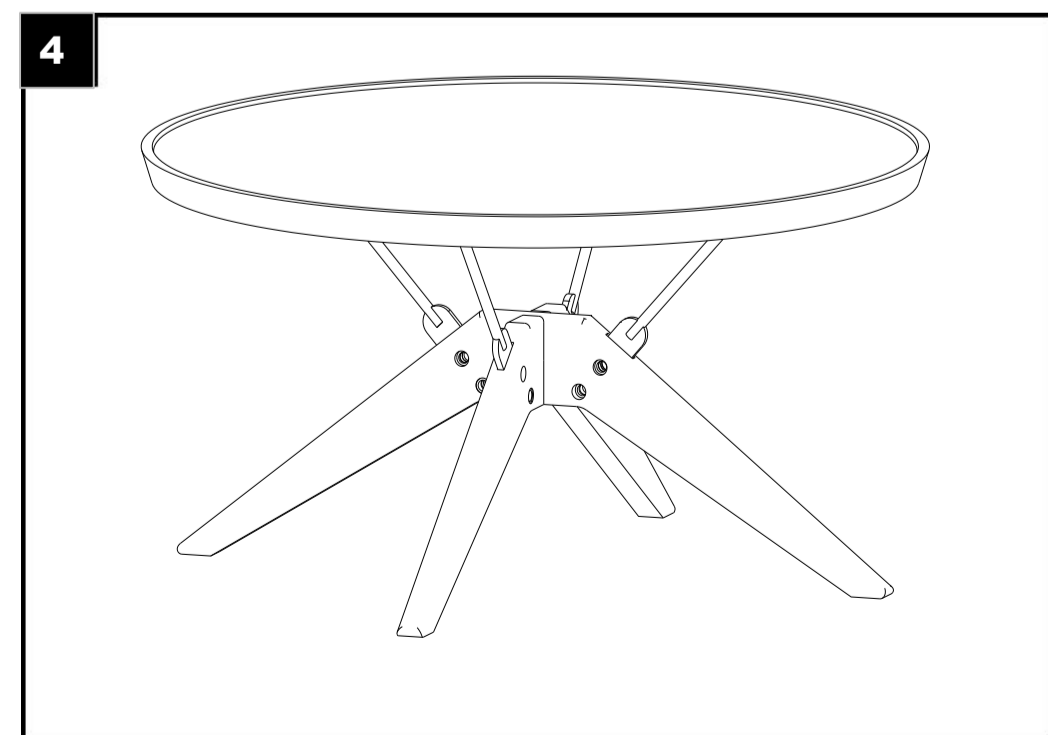

Step 4 : TURN AND FINISH