

# Model: 81276/81276i Installation Instructions

## TOOLS AND MATERIAL REQUIRED

- A. Water Supply Kit (Not needed if replacing existing toilet)
- B. Adjustable Wrench
- C. Flathead Screwdriver
- D. Level
- E. Nut Driver or Socket Set
- F. Putty Knife
- G. Tape Measure

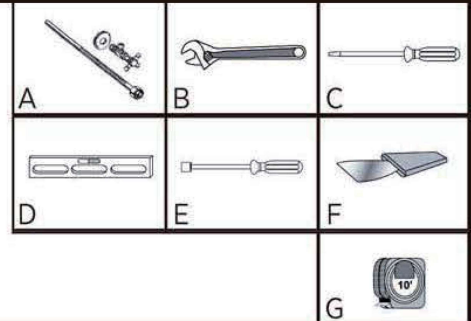

## 1. REMOVING YOUR OLD TOILET

- 1 Turn off the water supply.
- 2 Flush the toilet to empty the tank. Remove any water left in the tank or bowl.
- 3 Disconnect the supply line from the tank.
- 4 Remove decorative caps. Unscrew nuts that attach the toilet to the floor.
- 5 Remove Toilet.

**IMPORTANT NOTE REGARDING WATER SUPPLY:** Before installation ensure that the shut-off valve is greater than 8-1/4" from the center of the drain to the center to shut-off valve on either side (Figure 1).

**NOTE:** This is a true 12" rough-in toilet from finished wall to center of the drain (no less than 12"). Baseboard thickness may reduce rough-in dimension.

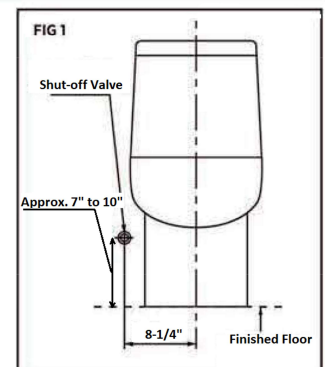

## 2. INSTALLING YOUR NEW TOILET

- 1 Be sure the water supply valve is shut off before installation.
- 2 Clean any old wax, putty, etc, from base area. Draw a cross guideline at the point which is 305mm (12") away from the roughing in center to the wall. (see Fig 1)
- 3 According to the requirements, confirm the place of drilling to fix the floor screws.
- 4 Adjust the position of the mounting brackets. Install the mounting brackets and the floor screws.
- 5 Stick the wax to the drain hole of toilet bowl. Put the toilet bowl above the floor flange and adjust the toilet bowl to be closed to the wall. (see Fig 3)
- 6 Tighten the toilet bowl mounting screws and then put on the caps. (see Fig 4)  
**CAUTION: DO NOT OVER TIGHTEN. SEVERE DAMAGE MAY OCCUR.**
- 7 Put on glass glue to fix toilet.

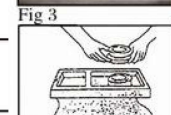
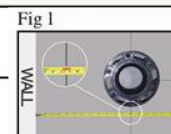

## 3. TOILET SEAT INSTALLATION INSTRUCTIONS

- 1 Separate the seat mounting brackets with the hardware, namely, screws, washers, plastic bushings and plastic tapered nuts.
- 2 Insert the plastic bushings and tapered nuts from the bottom into the holes in the back of the toilet bowl.
- 3 Align the mounting brackets with the plastic bushing and place the washer into the slot of the mounting brackets and insert the screws.
- 4 Before all the way tightening the screws, insert the seat cover onto the pins of the mounting brackets; align the seat with the toilet rim and tighten the screws.
- 5 Take out the seat by pressing the release button(s); install the mounting bracket covers over the pins and insert the seat back onto the pins.

## 4. CARE AND CLEANING

DO NOT use in-tank bowl cleaners. The use of high concentration of chlorine or chlorine-related products can damage the fittings inside the tank and cause leakage. Innoci-usa shall not be responsible for any tank fitting damage or failure caused by the use of in-tank bowl cleaners.

## 5. PART REPAIR LIST

Fill Valve: ABL-2018 & Flush Valve: ABL-4009

# Warranty

Our products have been manufactured under the highest standards of quality and workmanship. innoci usa warrants to the original purchaser that our products are free from any defects in material and workmanship by normal use for 1 year from the date of purchase. A replacement for any defective part will be supplied FREE OF CHARGE for installation by you.

This warranty is valid to the original purchaser only and does not cover product damage due to installation error, product abuse, product misuse, etc. whether or not performed by professionals. innoci usa will not be responsible for labor charges and/or damage incurred in installation, repair or replacement nor for any incidental or consequential damages.

All warranty claims should be sent to [customerservice@innoci-usa.com](mailto:customerservice@innoci-usa.com) or call 1.866.479.8076. Our customer service representative will contact you promptly to help you go through the process until you are completely satisfied with our products.

**SHORTAGE OR DAMAGED PRODUCTS** All shipments are carefully inspected and counted before leaving our distribution centers. Please inspect carefully on receipt of merchandise, noting any discrepancy or damage on the carrier's freight bill at that time, and file a claim with the carrier within 10 days from receipt of order. Then contact our office. Deductions from invoices for shortages or damage claims will not be allowed.

**RETURN NEW GOODS** All claims for returns or adjustments must have prior approval and return authorization (RA) number. Only original, sealed product in salable condition are eligible for return. Credit for authorized returns will be issued at the net price paid for the product and subject to a 15% restocking/handling fee. Merchandise is to be returned via prepaid freight. All unauthorized returns will be refused or subject to a 25% restocking/handling fee. To request an "RA" number: Contact our Customer Service Representatives at [customerservice@innoci-usa.com](mailto:customerservice@innoci-usa.com). We will send you a Return Authorization Number (RA) by return email. Please take necessary precautions when returning merchandise to prevent additional damage. Insurance is the responsibility of the shipper.