

# INSTALLATION INSTRUCTION

## Steampunk - Outdoor

WS-W24509, WS-W24513

# WAC LIGHTING

Responsible Lighting®

### WARNING

IMPORTANT: NEVER attempt any work without shutting off the electricity.

- Read all instructions before installing.
- System is intended for installation by a qualified electrician in accordance with the National Electrical Code and local regulations.
- Go to the main fuse box, or circuit breaker. Place the main power switch in the "OFF" position and unscrew the fuse(s) or switch "OFF" the circuit breaker switch(es) that control the power to the fixture or room that you are working on.
- Place the wall switch in the "OFF" position.

### CAUTION

- All parts must be used as indicated in these instructions. Do not substitute any parts, leave parts out, or use any parts that are worn out or broken. Failure to follow this instruction could invalidate the ETL/CETL listing of this fixture.  
CAUTION When handling the fixture, do not apply pressure to the LEDs. Hold the fixture by the base only.

### AVERTISSEMENT

IMPORTANT : Coupez l'électricité avant TOUTE manipulation.

- Lisez toutes les instructions avant d'installer.
- Système est destiné à être installé par un électricien qualifié en conformité avec le code national de l'électricité et les règlements locaux.
- Accédez au panneau central de disjoncteurs ou de fusibles de votre demeure et placez l'interrupteur principal en position d'arrêt (« OFF »).
- Placez l'interrupteur mural en position d'arrêt (« OFF »).

### MISE EN GARDE

- Toutes les pièces doivent être utilisées tel qu'il est indiqué dans ces instructions. Ne remplacez pas les pièces, n'en laissez pas de côté et ne les utilisez pas si elles sont usées ou brisées. Le non-respect de ces instructions peut annuler l'homologation ETL/CETL du luminaire. MISE EN GARDE Ors de la manipulation de l'appareil, ne pas appliquer de pression à la LED, tenir l'appareil par la seule base.

### ADVERTENCIA

IMPORTANTE: NUNCA intente hacer trabajos sin desconectar el suministro eléctrico.

- Lea y comprenda todas las instrucciones e ilustraciones por completo antes de proceder con el ensamblaje e instalación de esta lámpara.
- Sistema está diseñado para ser instalado por un electricista calificado, de acuerdo con el código eléctrico nacional y las normas locales.
- Diríjase a la caja de fusibles o a la caja del interruptor de circuito principal en su hogar. Coloque el interruptor de alimentación principal en la posición "OFF" (APAGADO).
- Coloque el interruptor de la pared en la posición "OFF" (APAGADO).

### PRECAUCIÓN

- Todas las piezas deben usarse como lo indican estas instrucciones. No reemplace las piezas, no omita piezas durante la instalación ni utilice piezas gastadas o rotas. El incumplimiento de esta indicación podría invalidar la calificación ETL/CETL esta lámpara. PRECAUCIÓN Al manipular el aparato, no aplique presión a los LED, mantenga el aparato en la base sólo.

### HARDWARE

B1



Fixture Screw  
Qty: 1pc  
+ 1 extra

D1



Wire  
Connector  
Qty: 3pc

F1



Hex Nut  
Qty: 1pc

G1



Washer  
Qty: 1pc

H1



Junction Box  
Screw  
Qty: 2 + 1pc

L1



Nipple  
Qty: 1

J1



Washer  
Qty: 1

K1



Screw Nut  
Qty: 1pc

N1



Screw  
Qty: 2pc

O1



Glass Clip  
Qty: 2pc

### WAC Lighting

www.waclighting.com

Phone (800) 526.2588 • Fax (800) 526.2585

### Headquarters/Eastern Distribution Center

44 Harbor Park Drive • Port Washington, NY 11050

Phone (516) 515.5000 • Fax (516) 515.5050

### Western Distribution Center

1750 Archibald Ave • Ontario, CA 91761

Phone (800) 526.2588 • Fax (800) 526.2585



# INSTALLATION INSTRUCTION

## Steampunk - Outdoor

WS-W24509, WS-W24513

# WAC LIGHTING

Responsible Lighting®

Fig. 1

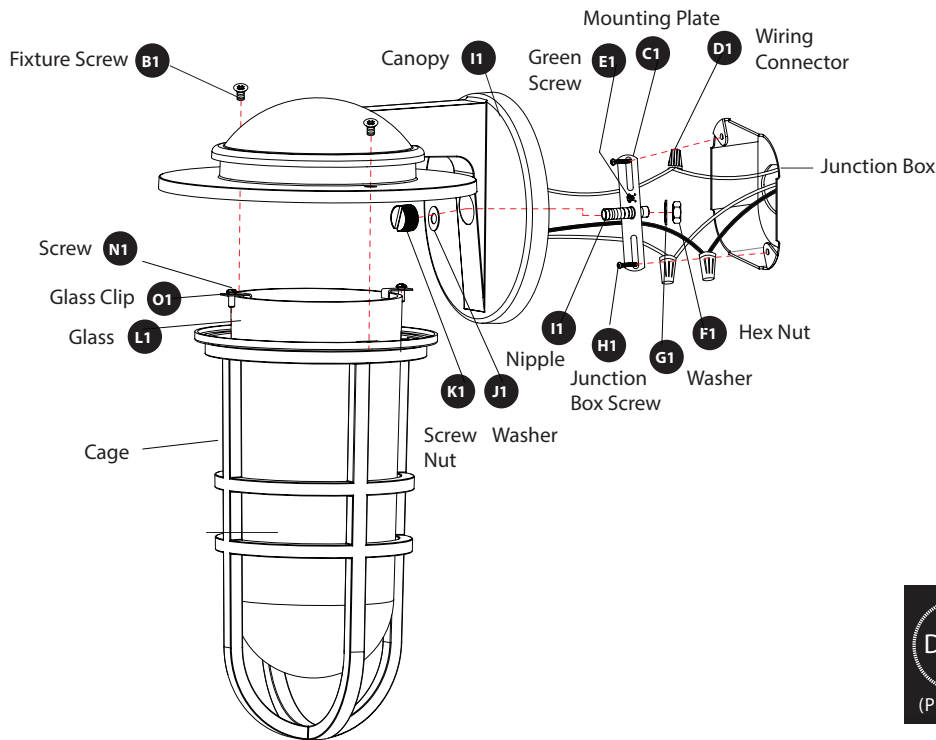

### PREPARATION

- Shut off the power at the circuit breaker and remove existing fixture, including the mounting hardware.
- Carefully unpack your new fixture and lay out all the parts on a clear area. Be careful not to lose any small parts necessary for installation.

### MOUNTING THE FIXTURE (FIG. 1)

1. Secure the mounting plate (C1) to the junction box using junction box screws (H1). The side of the mounting plate marked "GND" must be face out.

### CONNECTING THE WIRES (FIG. 2)

2. Connect the fixture wires with the supply wires as shown in **Fig.2**. Make sure that all wire connectors (D1) are secured. If your outlet box has a ground wire (green or bare copper), connect the fixture's ground wire to it. Otherwise, connect the fixture's ground wire directly to the mounting plate (C1) using the green screw (E1) provided. After wires are connected, tuck them carefully inside the junction box.
3. Secure the nipple (I1) to the mounting plate (C1) with washer (G1) and hex nut (F1), Put the fixture onto the mounting plate's nipple (I1), tight the fixture with washer (J1) and Screw nut (K1).
4. Put the glass (L1) into the cage (A1), secure with glass clip (O1) by using two screws (N1), and put the cage with the glass on to the fixture and tight it with the screw (B1)

### MOUNTING THE FIXTURE

5. To prevent moisture from entering the outlet box and causing a short, use clear caulking (i.e. indoor/outdoor silicone sealant) to outline the outside of fixture back plate where it meets the wall. Leave a space at the bottom to allow moisture to escape **Fig.3**.

Fig. 2

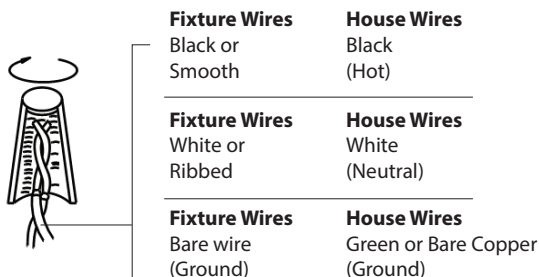
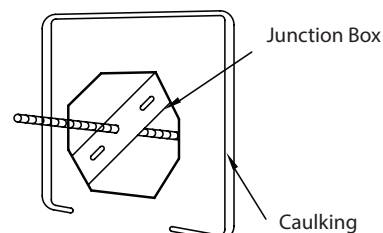

Fig.3 Sealing



WAC Lighting

www.waclighting.com

Phone (800) 526.2588 • Fax (800) 526.2585

Headquarters/Eastern Distribution Center

44 Harbor Park Drive • Port Washington, NY 11050

Phone (516) 515.5000 • Fax (516) 515.5050

Western Distribution Center

1750 Archibald Ave • Ontario, CA 91761

Phone (800) 526.2588 • Fax (800) 526.2585

