

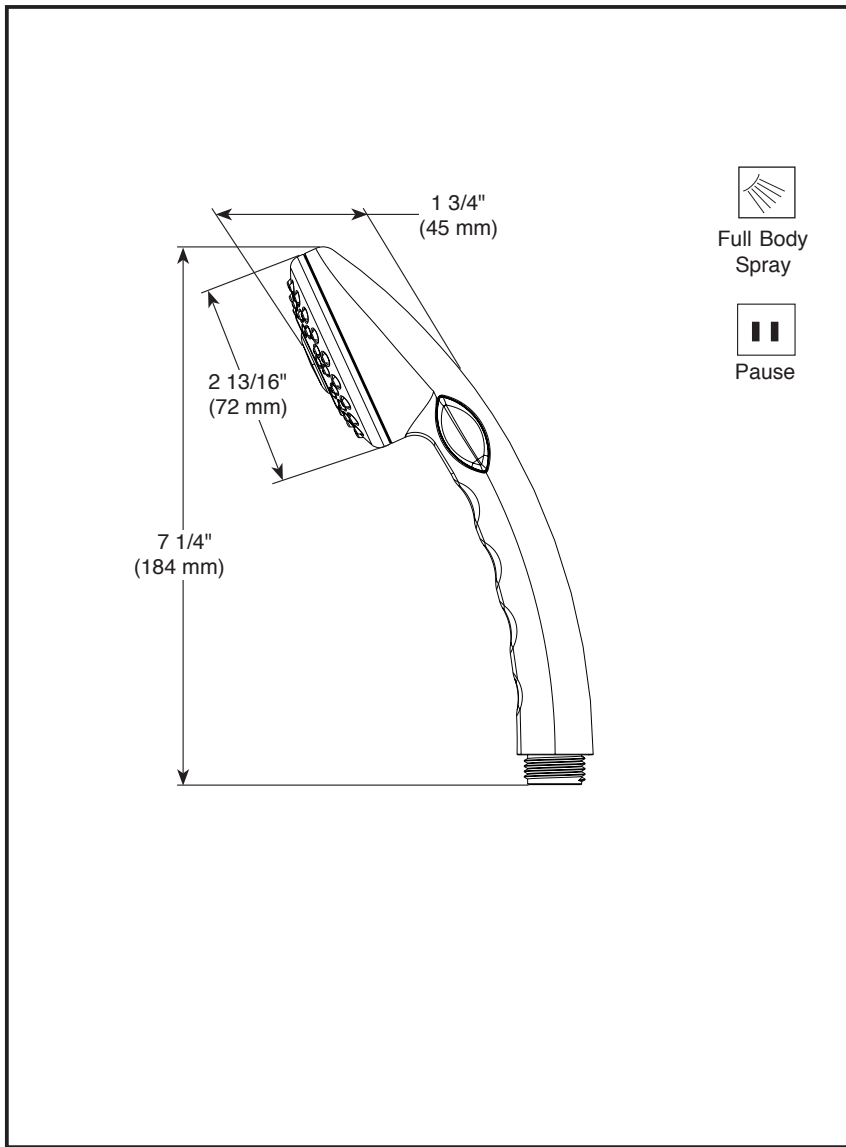

59462-▲B15-BG

Submitted Model No.: _____

Specific Features: _____



Full Body Spray



Pause



PERSONAL HAND HELD SHOWER NO MOUNT

- 2-Spray Setting Showerhead
- Touch-Clean® Nozzles

STANDARD SPECIFICATIONS:

- Maximum flow rate 1.5 gpm (5.7 L/min) @ 80 PSI.
- Touch-Clean® nozzles to remove mineral deposits.
- ADA compliance applies to the hand shower.
- Manufactured using engineering grade plastics.

WARRANTY

- Lifetime limited warranty on parts (other than electronic parts and batteries) and finishes; or, for commercial users, for 5 years from the date of purchase.
- 5 year limited warranty on electronic parts (other than batteries); or for commercial users, for 1 year from the date of purchase. No warranty is provided on batteries.



COMPLIES WITH

- ASME A112.18.1 / CSA B125.1 ◆
 - EPA WaterSense®
- ◆ Your Delta Faucet handshower incorporates a backflow protection system that has been tested to be in compliance with ASME A112.18.3 and ASME A112.18.1/CSA B125.1. It incorporates two certified check valves in series, which operate independently and are integral, non-serviceable parts of the wand assembly.

▲ Designate proper finish suffix

Delta reserves the right (1) to make changes in specifications and materials, and (2) to change or discontinue models, both without notice or obligation. Dimensions are for reference only. See current full-line price book or www.deltafaucet.com for finish options and product availability.

DSP-B-59462-B15-BG Rev. C



55 E. 111th Street, Indianapolis, Indiana 46280
350 South Edgeware Road, St. Thomas, Ontario Canada N5P 4L1
© 2015 Masco Corporation of Indiana