

Assembly Instructions

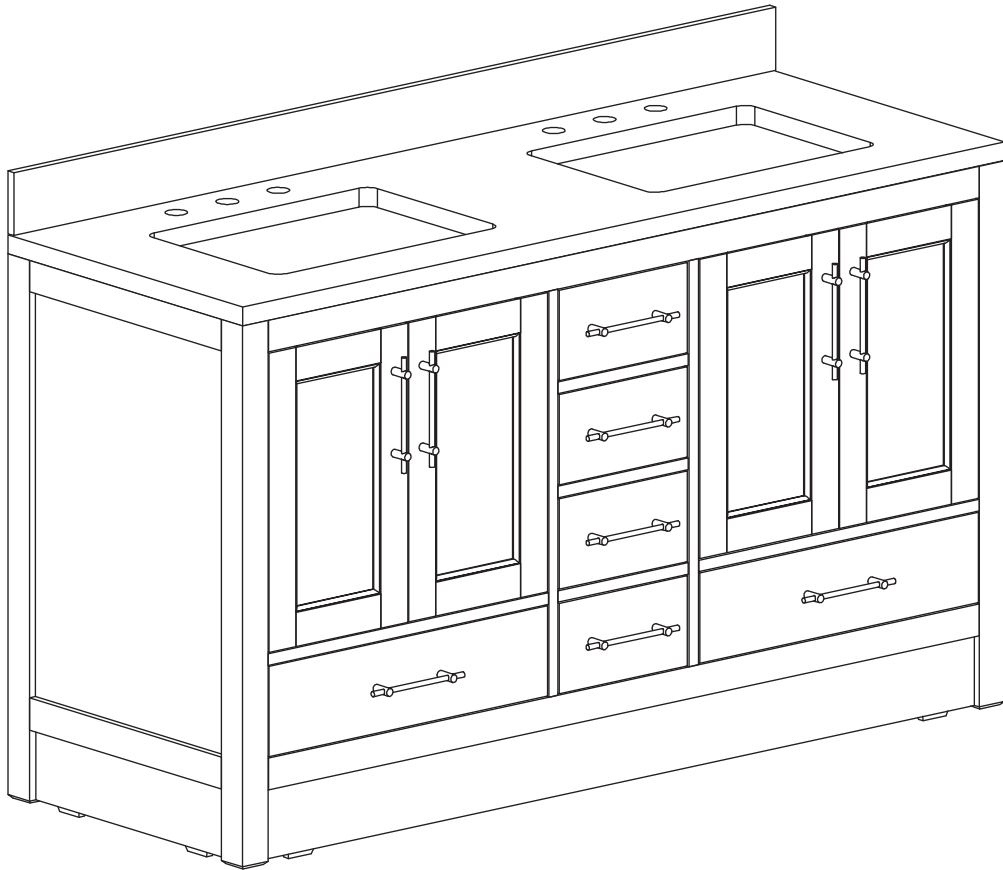

PRODUCT TYPE: BATHROOM VANITY

PRODUCT NAME: KENDALL VANITY WITH PLINTH KIT

SIZE: 60 INCH

Marble Top Handling

Always use two people to handle the marble top.

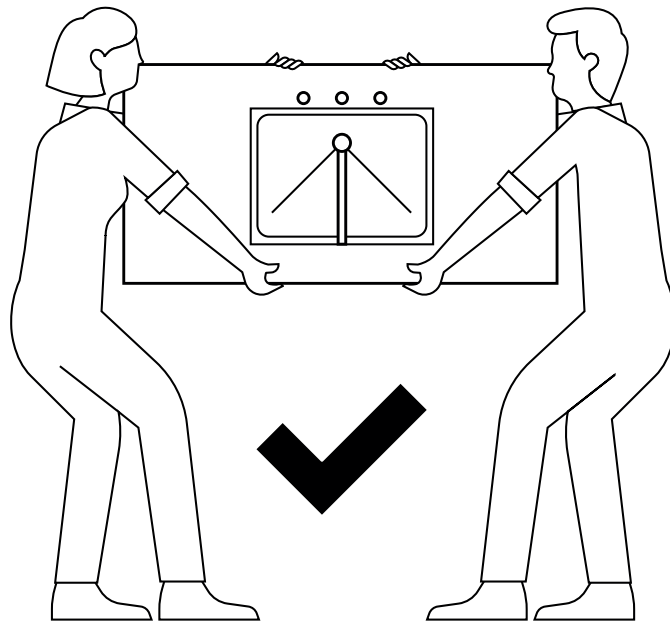

Always lift the marble top vertically.

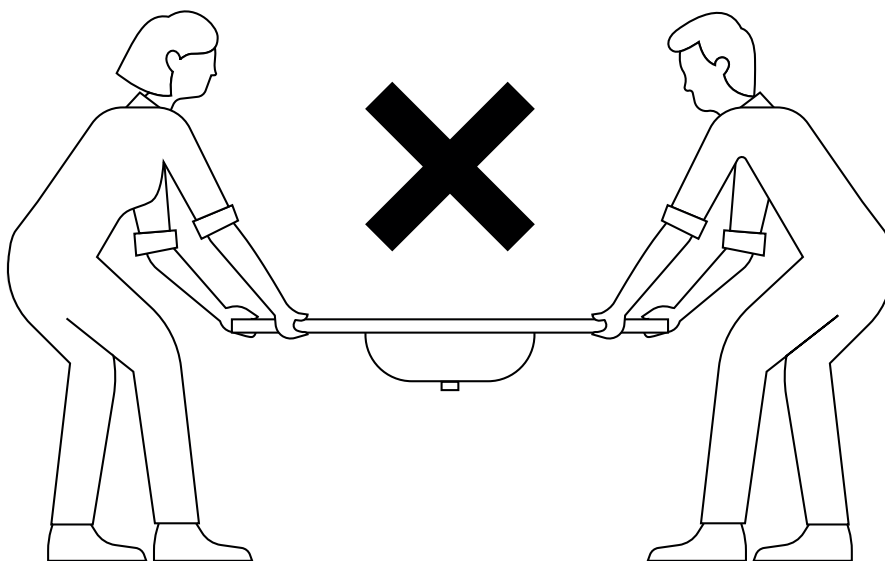

Do not lift the marble top horizontally.

Before Assembling

- **Professional installation recommended.**
 - **Please read this sheet prior to assembly to familiarize yourself with the various stages of construction.**
 - Carefully unpack the components supplied and check the parts and fitting against the check list.
 - Do not destroy any of the packaging until you are certain that you have all the necessary parts of assembly.
 - Please ensure that the packaging is disposed of in a safe, environmentally friendly way.
 - **Caution:** There are small components used in the construction of this unit. These loose items should be kept away from young children whilst assembling your unit to avoid the danger of choking hazard.
 - Examine the marble top for cracks, chips and defects. In case defects are detected, please contact customer services, do not install.
 - To clean the marble from dust, wipe it with a wet cloth.
-

Warnings

- Observe all plumbing and building codes.
- Before installation, verify cabinet clearance.
- Always use two people when installing the marble tops.
- Anti-Tip kit included.
- **Caution:** Always turn off the water supply before removing an existing faucet or replacing any part of a faucet. Open the faucet handle to relieve water pressure and ensure that the water is completely shut off.

Component Checklist

Tools Required

- Screwdriver
 - Sealant
 - Carpenters Level
-

Components Supplied

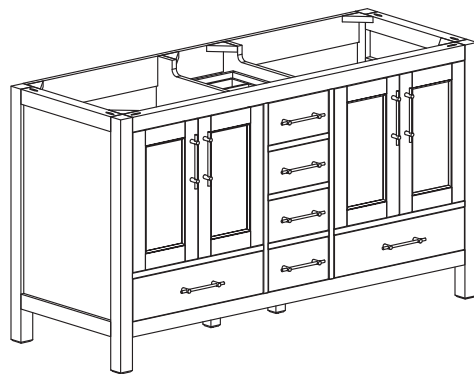

Vanity Base x 1
(Kendall 48")

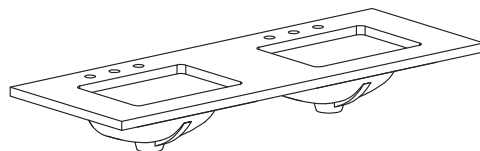

Top + Basin x 1

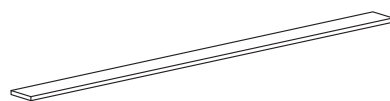

Backsplash of Marble Top x 1

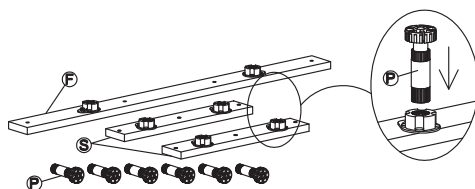

Mounting Strips x 3

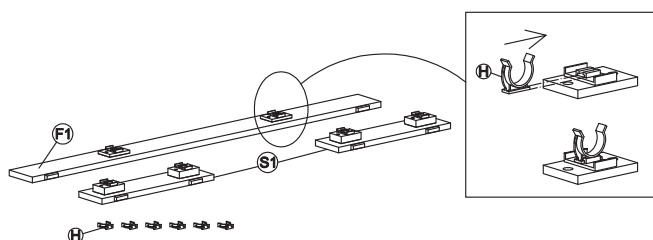

Plinth Strips x 3

Step By Step Instructions

Step 01: Assemble the handle.

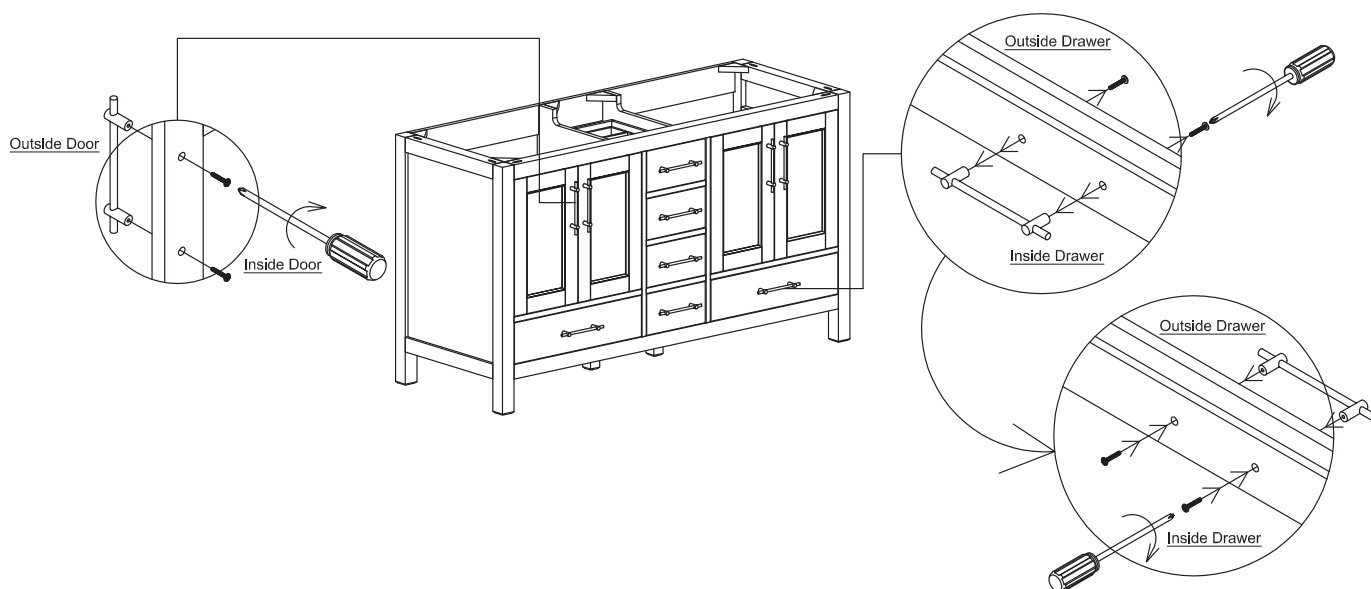

Step 02: Assemble the Side Mounting Strip (S).

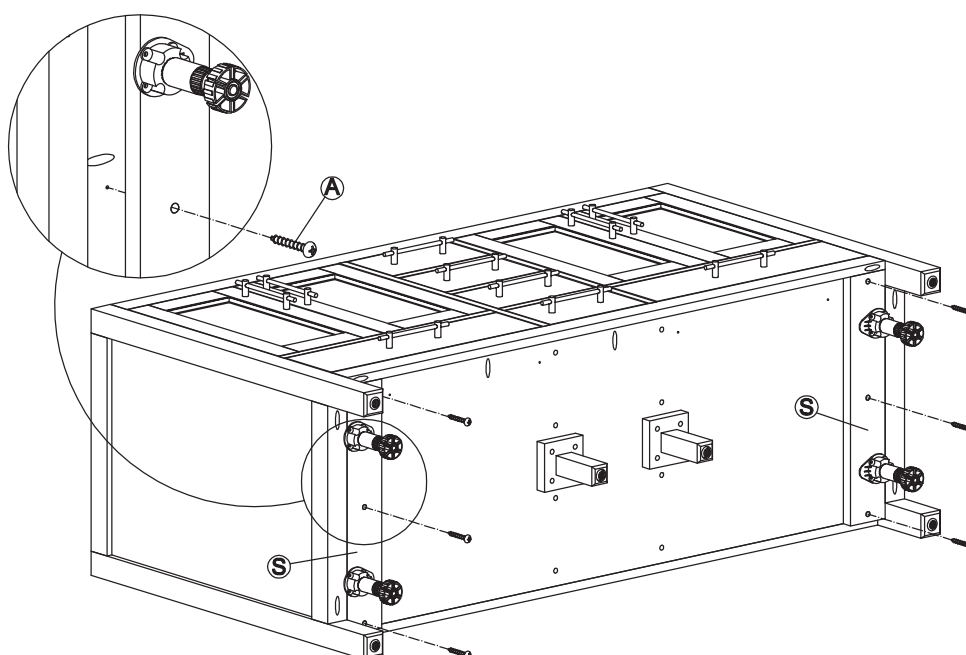

Step By Step Instructions

Step 03: Assemble the Front Mounting Strip (F).

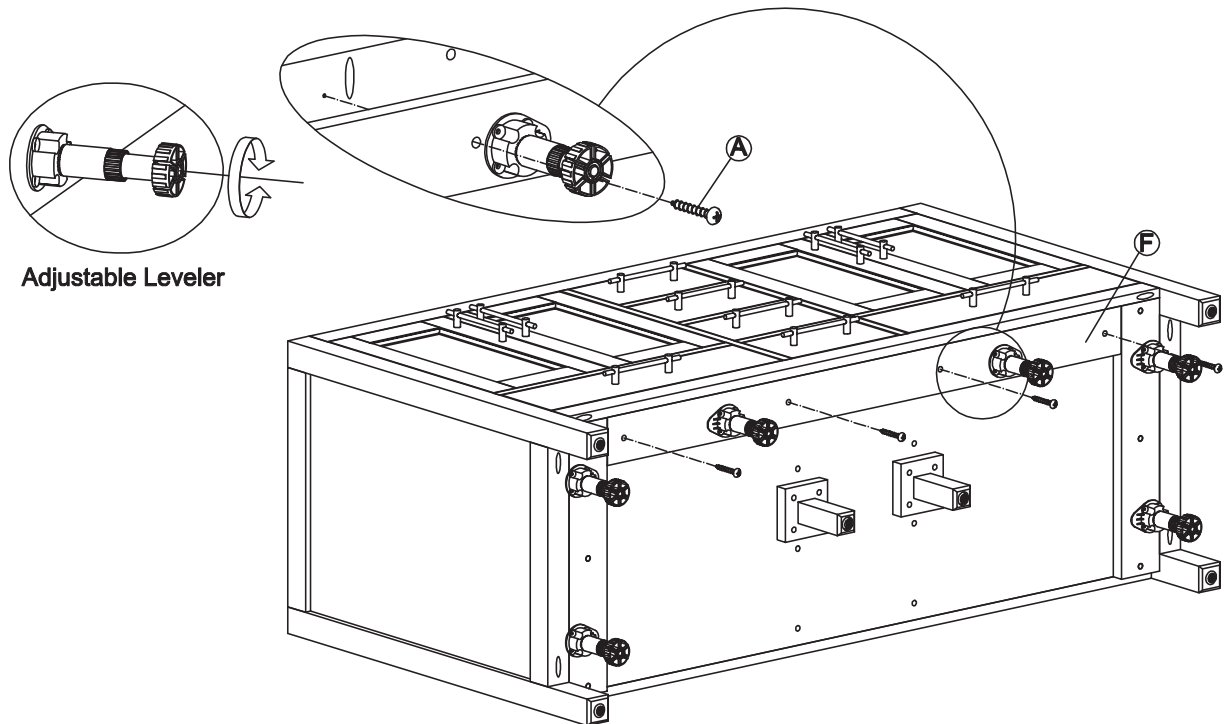

Step 04: Assemble the Plinth Strips (F1 + S1)

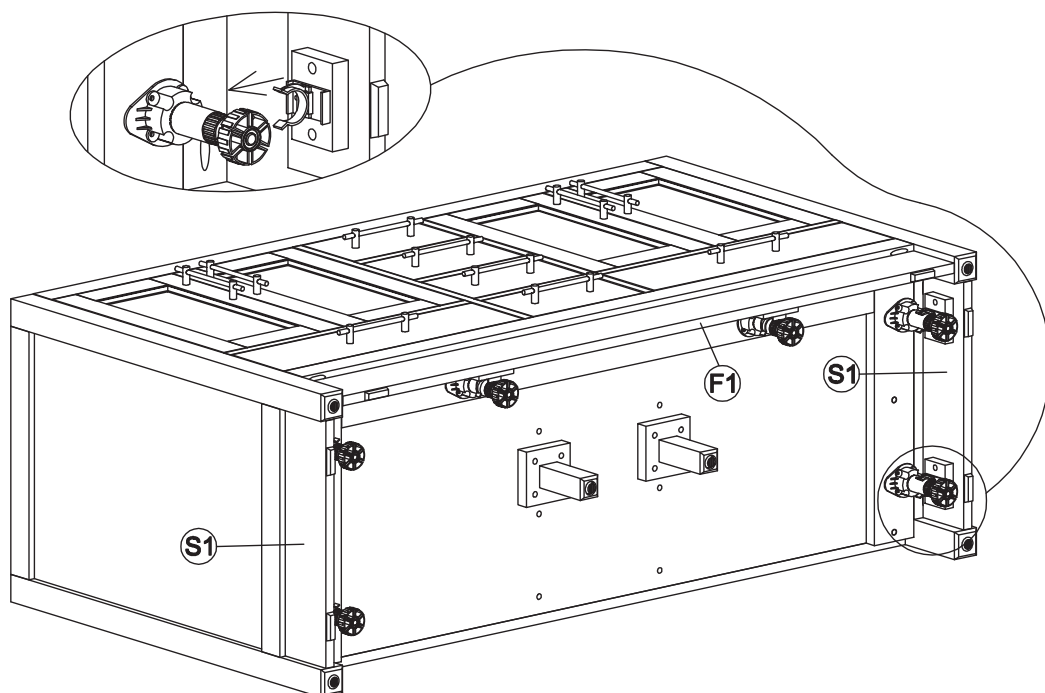

Step By Step Instructions

Step 05: Stand the vanity upright.

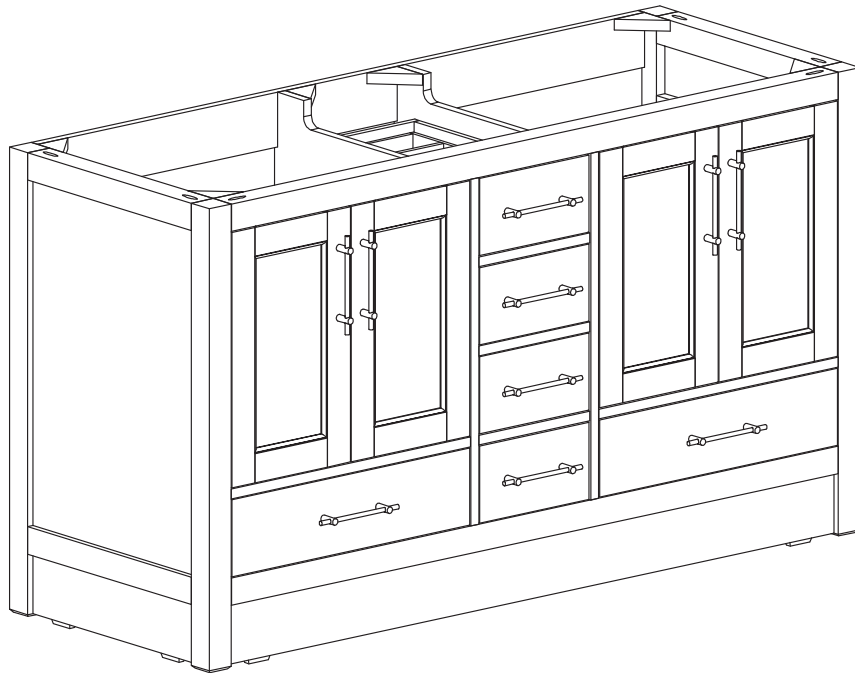

Step 06: Adjust the feet.

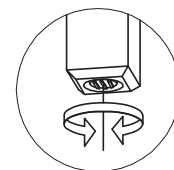
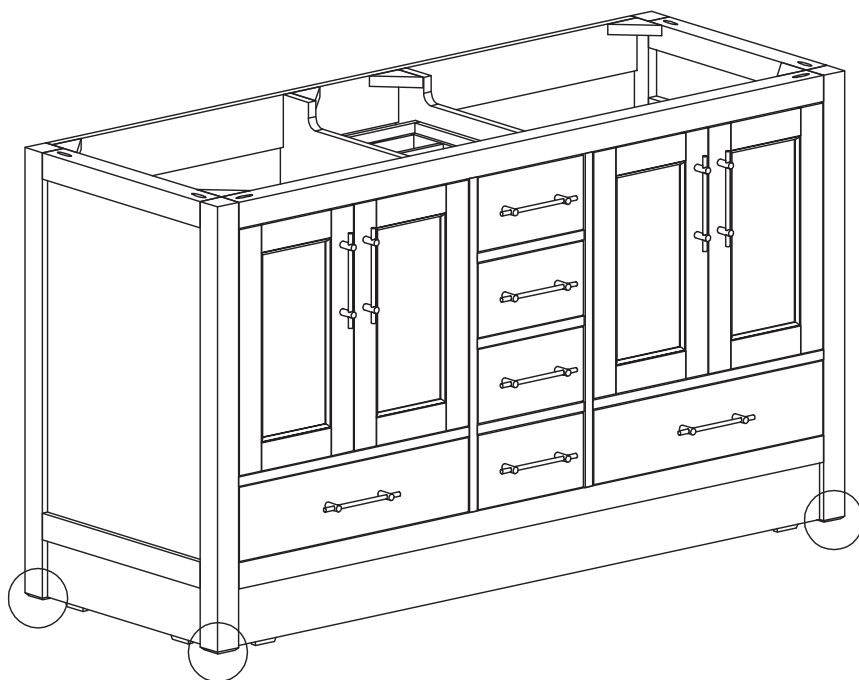

Adjustable Leveller

Step By Step Instructions

Step 07: Assemble the marble top.

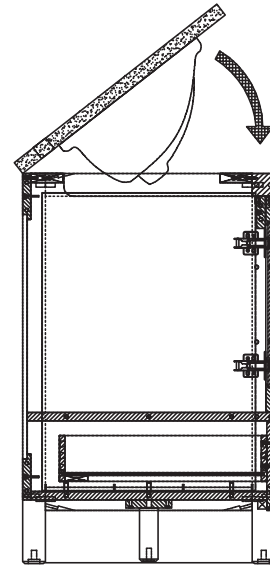
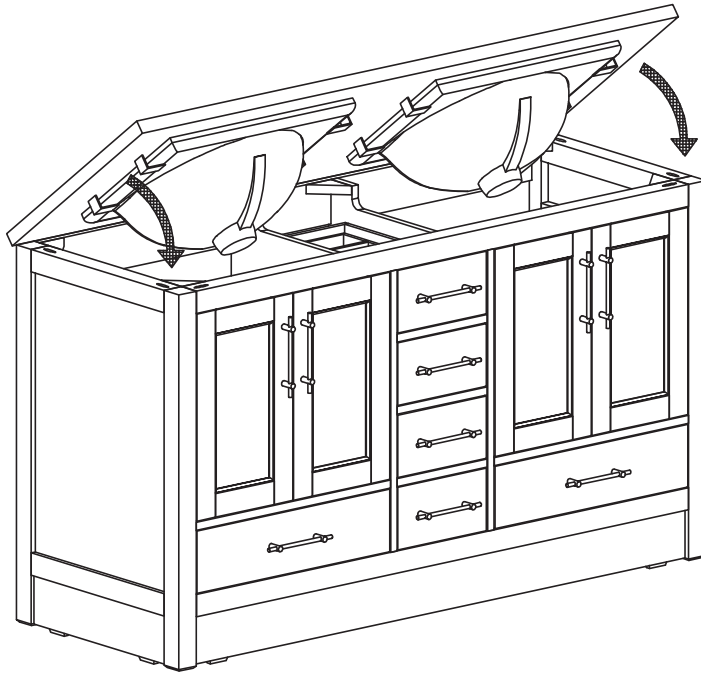

Step 08: Assemble the backsplash of marble top.

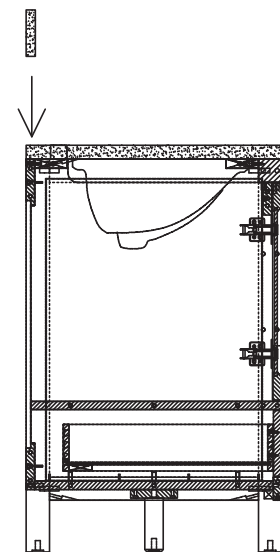
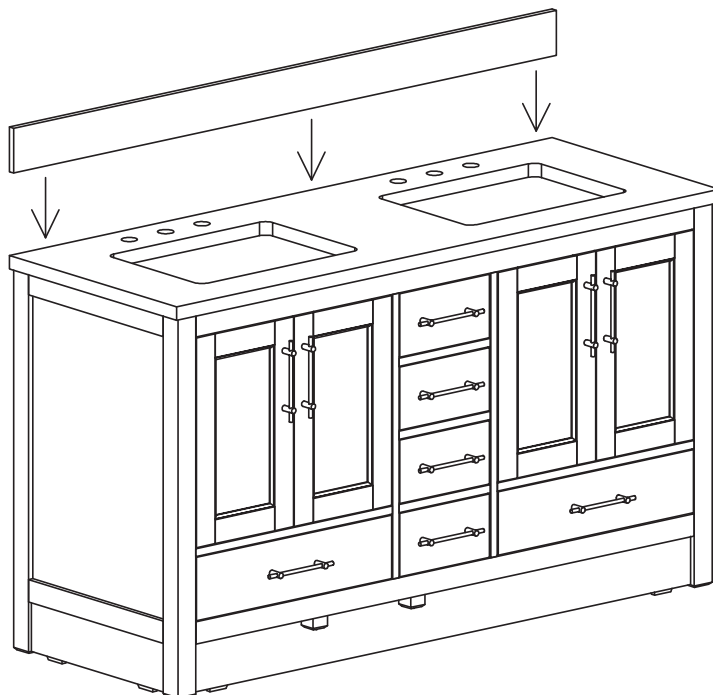

Care & Maintenance

Cleaning & Care (Vanity)

- Clean the product by using a soft, slightly damp cloth.
- Buff the product by using a soft dry cloth.
- Avoid using silicone cleaners and waxes.
- Clean up excess water and spills immediately. Use a blotting rather than a wiping action. Water left over a long period of time will cause white spots in the finish.
- NOTE: Please note that some chemicals may damage the finish.

Cleaning & Care (Marble Vanity Top)

- Marble is porous and easily stained. We recommend treating the marble top with a marble stone sealant on a regular basis.
- It should be washed or cleaned regularly with fresh warm water and a non-abrasive clean cloth.
- All spills should be cleaned immediately.
- Avoid contact with all oils and petroleum-based products.
- Avoid contact with all acid or caustic products such as vinegar, citrus or fruit juices, soda, chlorine, and nail polish remover.
- If the marble is well sealed, the warm water and non-abrasive cloth should keep it clean.
- Retain these instructions for future reference.

Contact

For questions regarding your item, please call our Customer Support team at 1-800-368-4268 (Mon-Fri, 5am-7pm PT), or submit a support request help.houzz.com.

If you are not satisfied with your item, please request a return within 30 days of receiving the item at houzz.com/orders.

Icons designed by: [Flaticon.com](https://flaticon.com) / [Freepik.com](https://freepik.com) / [Vecteezy.com](https://vecteezy.com)

DAMAGED OR MISSING PARTS? PLEASE CONTACT OUR CUSTOMER HELPLINE: 1-800-368-4268 / help.houzz.com