





ASSEMBLY INSTRUCTION

Item#: 5750-90019-MWD Bed Bench

** Please make sure you have all parts indicated below prior to assembly.

NO	HARDWARD LIST		Q'ty
A		Bolt	12
B		Lock washer	12
C		Flat washer	12
D		Allen wrench	1

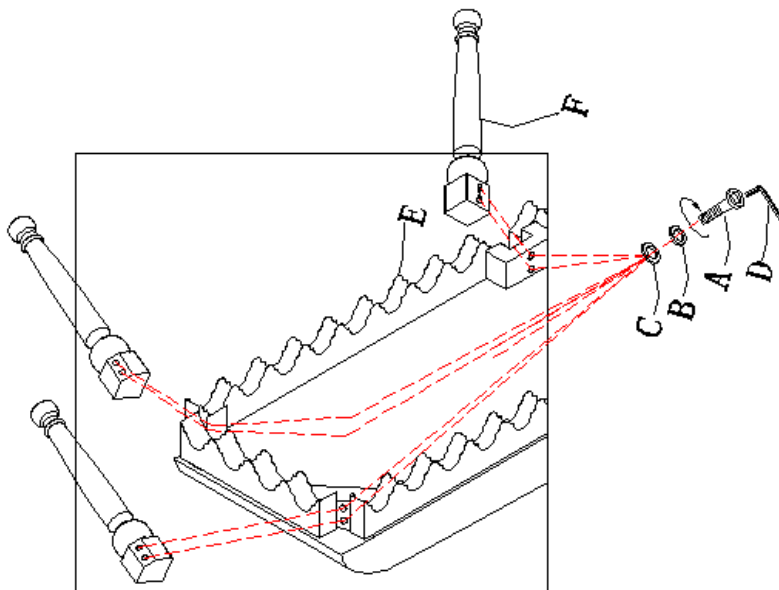
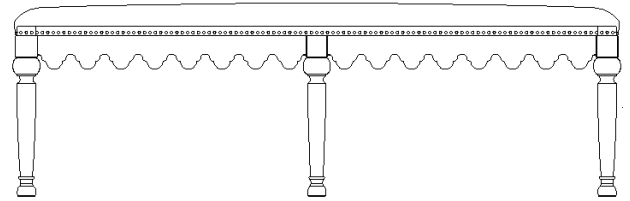

Diagram 1

Assembly Steps:

1. Put seat frame (E) upside down on a soft surface to prevent it from being scratched. (See Diagram 1).
2. Attach bench leg (F) to corner block of seat frame (E) by using bolts (A), lock washers (B) and flat washers (C), tighten with allen wrench (D) in clockwise direction (See Diagram 1).
3. Assemble other legs in the same way.
4. Turn bench upright.

Cleaning Instruction: Clean finished parts with a damp cloth using a mild dishwashing liquid and water solution. Polish the finish with soft cloth and an industry recognized furniture polish.