

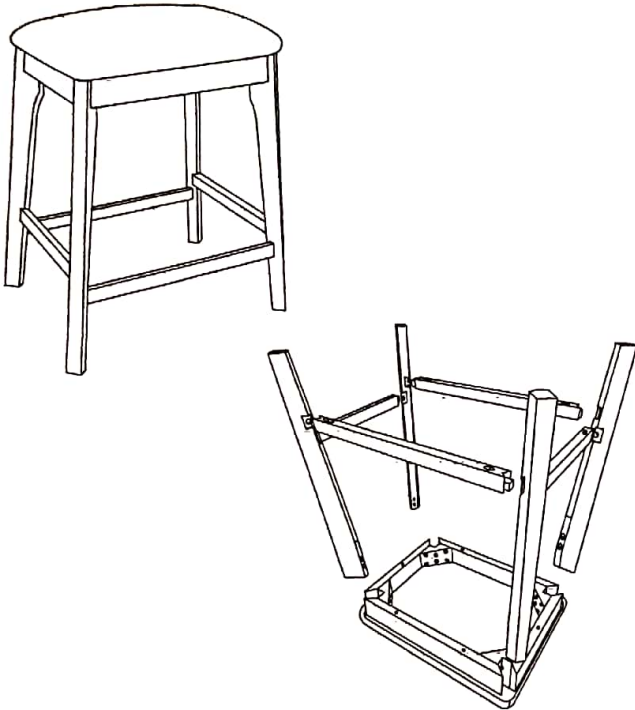

CAROLINA CHAIR & TABLE COMPANY

Thank you for purchasing a Carolina Chair & Table Company product. This product has been designed for easy assembly and is constructed for durability. Please take the time to read and follow the assembly instruction carefully. If a part or hardware is missing or you have any difficulties in assembling this product, please contact us Toll-Free at 1-800-228-3876

ASSEMBLY INSTRUCTION COUNTER/BAR TOOL HM280-24/30



PART CHECK LIST		
CODE	COMPONENTS	QTY
①	SEAT FRAME	x 01
②	RIGHT LEG	x 02
③	LEFT LEG	x 02
④	LONG STRETCHER	x 02
⑤	SHORT STRETCHER	x 02

FITTINGS CHECK LIST		
CODE	DESCRIPTION	QTY
Ⓐ	JCBC M6 x 50mm	x 08
Ⓑ	SPRING WASHER Ø1/4"	x 08
Ⓒ	FLAT WASHER Ø1/4" x 19mm	x 08
Ⓓ	PH SCREW M4 x 38mm	x 08
Ⓔ	L-KEY M4 x 65mm	x 01



PHILIPS HEAD SCREWDRIVER
TOOL NEEDED (NOT INCLUDED)

1 Attach stretchers (4) to left legs (3) to right legs (2). Use screw (D) to tighten the stretchers (4) to the left leg (3) and the right leg (2) with Philips head screwdriver.

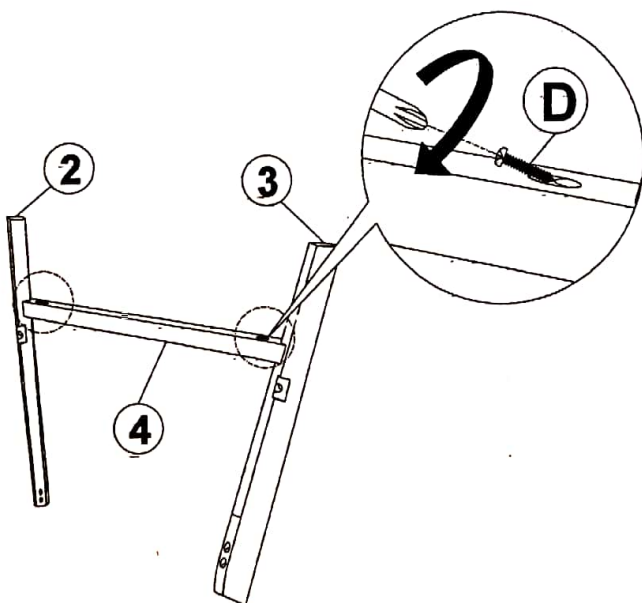

2 Place seat frame (1) upside down on a non-abrasive surface. Insert one leg assembly to seat frame (1). Use bolts (A), spring washer (B), flat washer (C) to tighten on each side with Allen key (E).
Do not tighten bolts (A) all the way

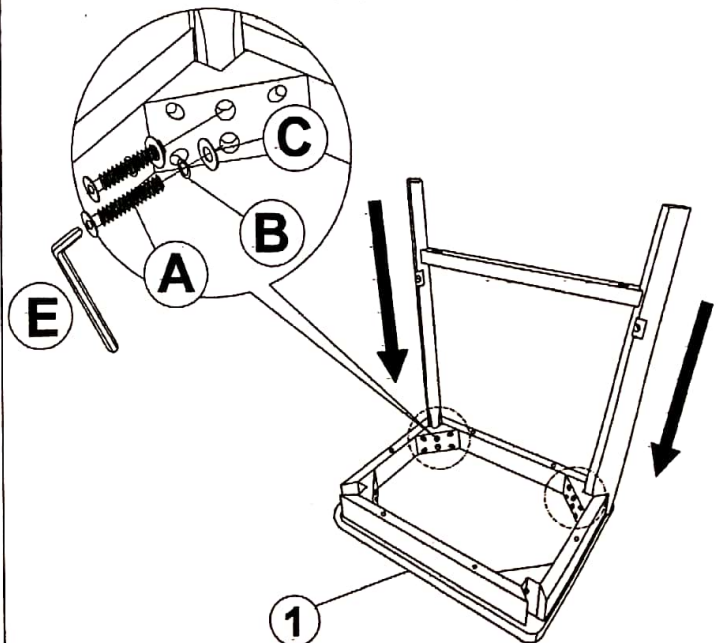

- 3** Attach stretchers (5) to both legs. Use screw (D) to tighten stretchers to both legs with Philips head screwdriver.

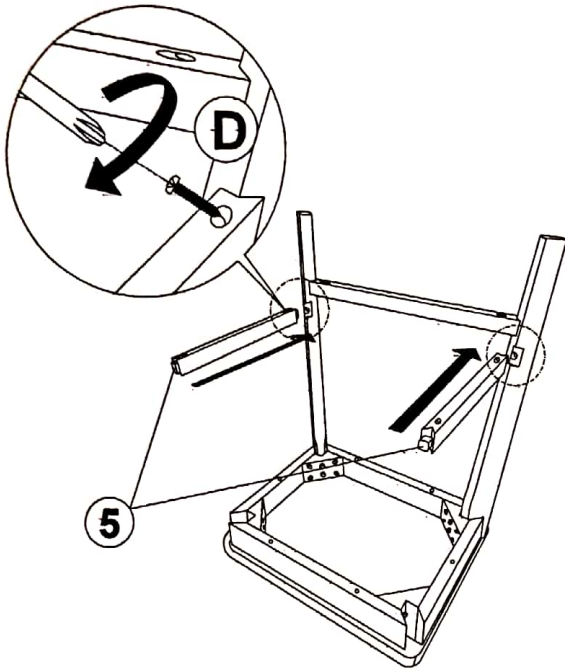

- 4** Insert second leg assembly to seat frame (1), stretchers (5) as shown. Use bolts (A), spring washer (B), and flat washer (C) to tighten leg assembly to seat frame (1) with Allen key (E).

Do not tighten bolts (A) all the way.

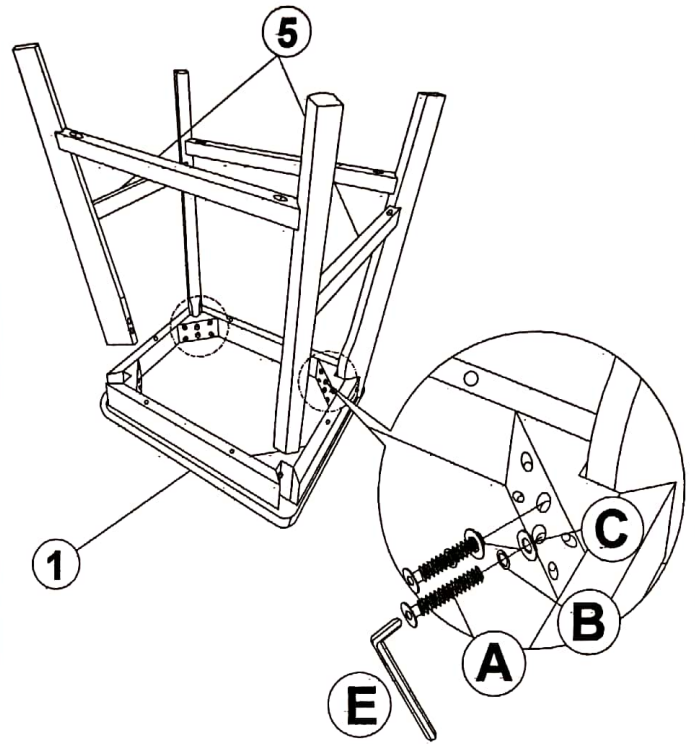

- 5** Use screw (D) to tighten the stretchers (5) to the leg assembly with Philips head screwdriver.

At this stage tighten all screws and bolts all the way 100%

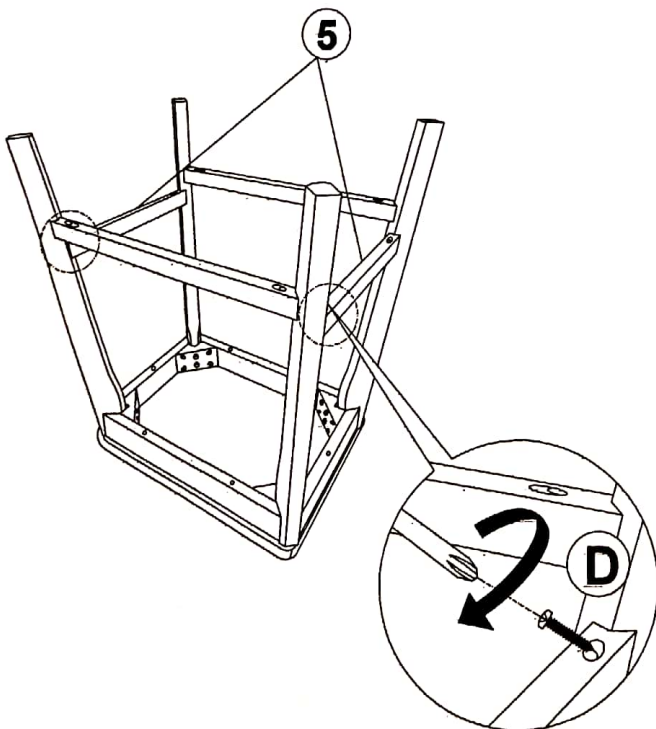

- 6** Assembly is complete.

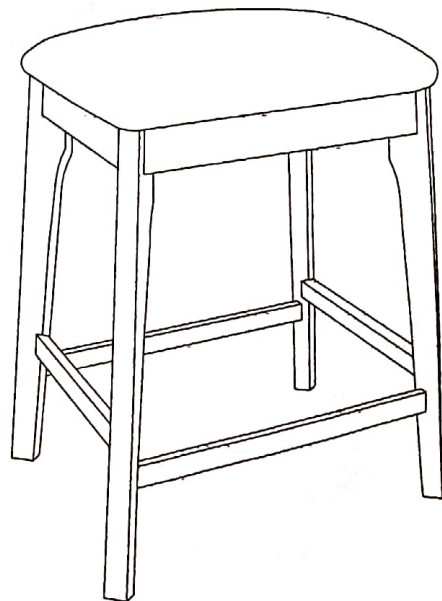

Carolina Chair & Table Co. Inc
Product Support 1 800-228-3876