

## USER GUIDE

### RECESSED MEDICINE CABINET – DOUBLE DOOR WITH LED LIGHTING

Model: 69233026, 69234026



(Items other than the mirror shown in the picture above are not included)

# IMPORTANT SAFETY INFORMATION

Please read through this installation instruction so you will know how to install and operate your model properly. Keep this document in a safe place for future reference after use.

## **WARNING**

This product must be installed in accordance with the installation instruction by qualified technician. Failure to follow instruction could result in death or serious bodily injury.

## **CAUTION**

This product must be serviced by qualified personnel. ALWAYS unplug the power cord or turn off the circuit breaker before service.

# PACKAGE CONTENTS

## Cabinet

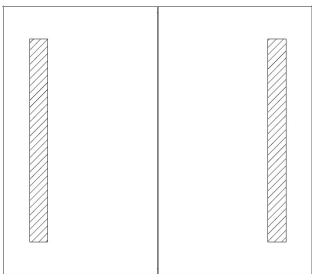

(x1)

## Glass Shelf



(x2)

## Shelf Support Pin



(x8)

## Wood Screw



(x4)

# INSTALLATION

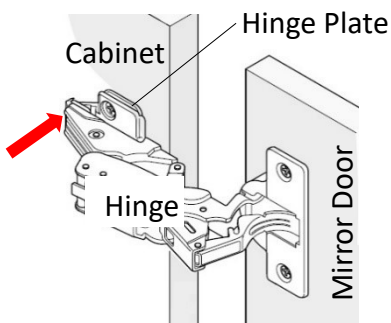

1. Unplug the cable from the Mirror Door to electrical enclosure. Remove the Mirror Door by pulling on the tab behind the Hinge to detach the hinge from the Hinge Plate. Remove the TOP hinge plate.

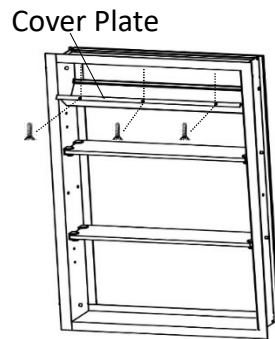

2. Loosen the electrical enclosure Cover Plate by removing the 3 screws and pivot down the Cover Plate.

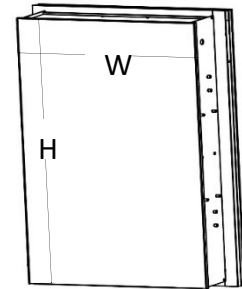

3. Measure the W (width) and the H (height) of the back of the cabinet

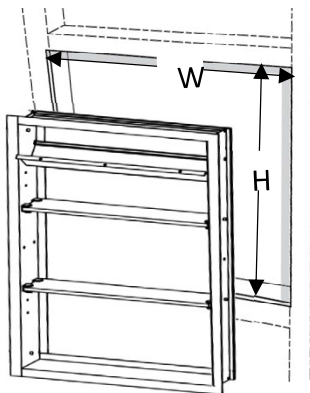

4. Frame out the wall cavity so the cabinet fits tightly into the recess.

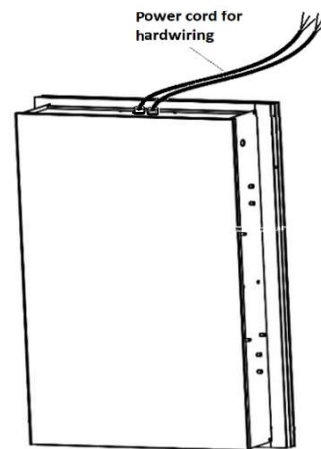

5. Power cord for hardwiring

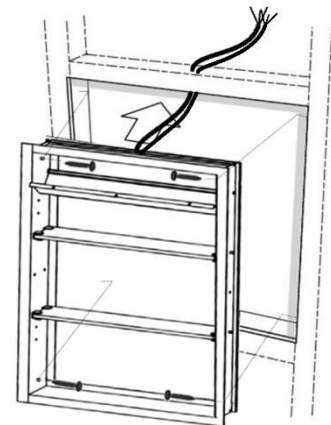

6. Insert and secure the cabinet; hardwire the power cord according to local electrical codes. You may hardwire both cables to the same power supply. Connect the wall switch to the white cable (Main) if one is used. A separate power supply is required for the Outlet (black cable).

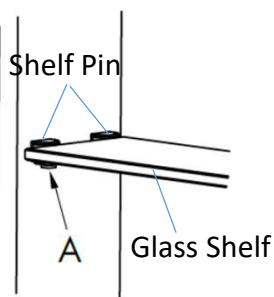

7. Insert Shelf Pins to desired height. Slide the Glass Shelf into position and tighten the plastic set screw (A)

8. Reinstall the Cover Plate and the Mirror Door(s)



- This mirror is NOT designed to work with dimmable wall switch.

# INSTALLATION DIMENSIONS

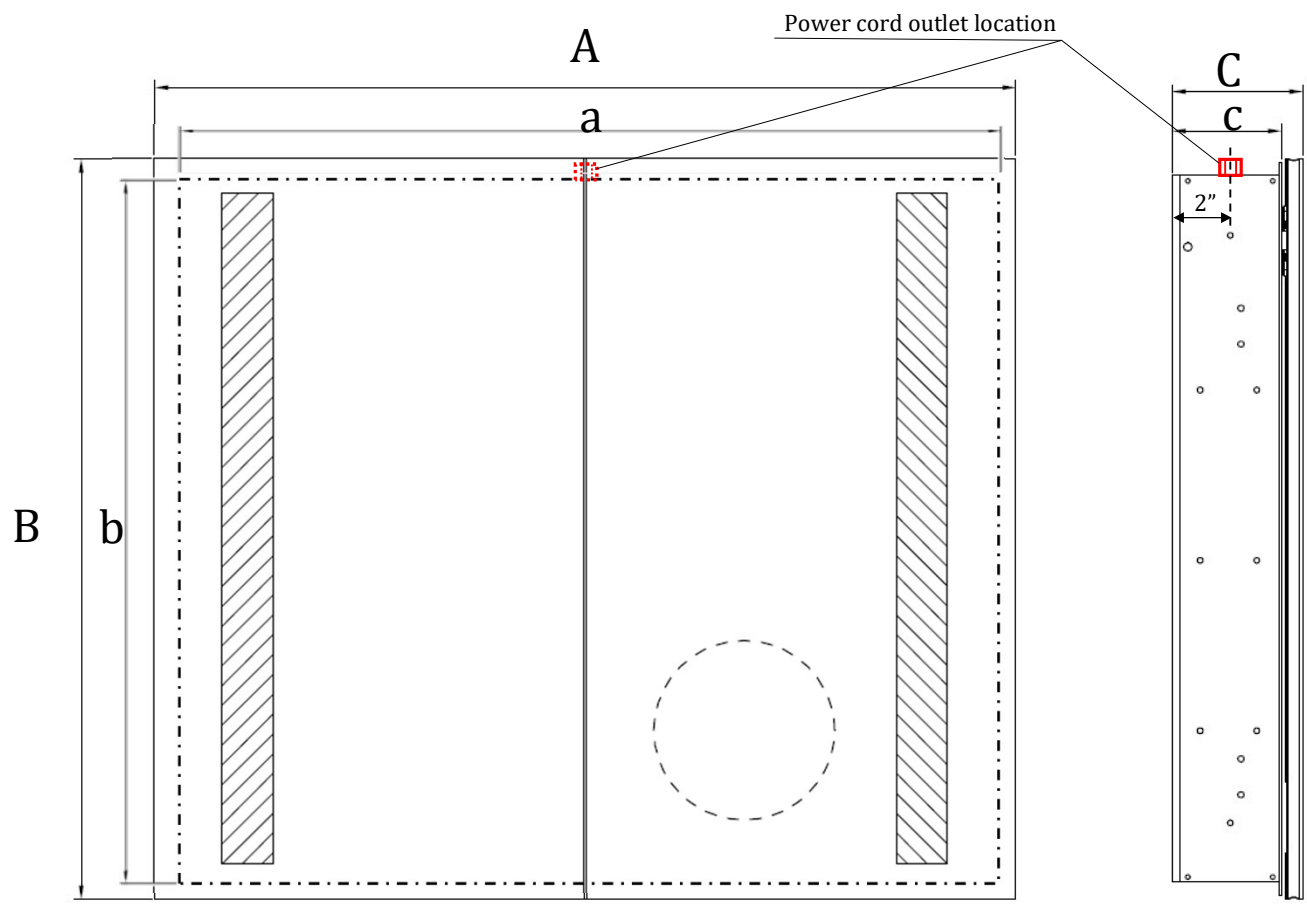

Model #	Overall Dimensions			Rough in Dimensions			Brightness (Lumen)	Power Consumption (Watt)
	A	B	C	a	b	c		
69233026	30	26	4-1/2	29	25	4	1065	17
69234026	40	26	4-1/2	39	25	4	1410	23

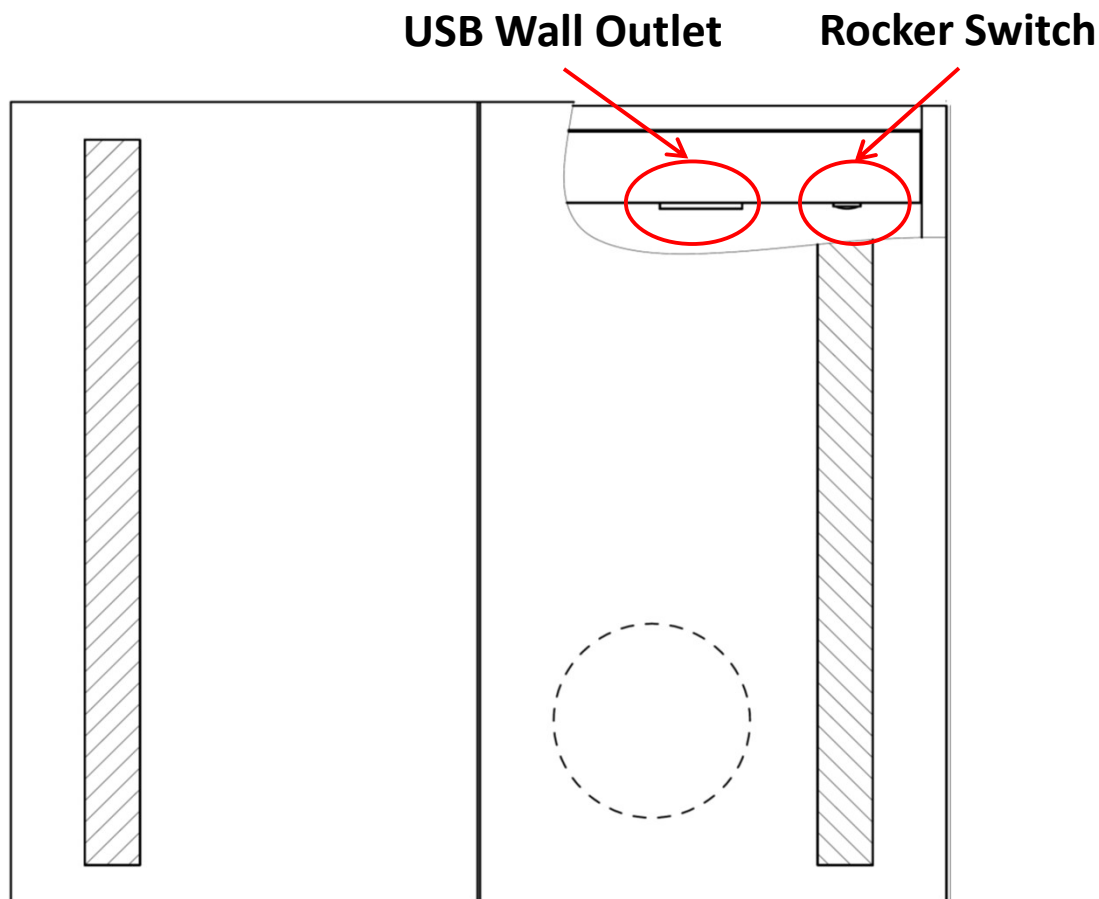

### 1. Rocker Switch

Located on top inside the medicine cabinet. Turn on the LED light by turning the switch to <|> position. Turn off the LED light by turning the switch to <O> position.

### 2. USB Wall Outlet

Located on top inside the medicine cabinet. It features two 3-prong outlets and 2 USB high-speed charger with 4.8A charging capability.

## CARE AND MAINTENANCE

Clean the mirror with a soft, damp cloth and dry thoroughly with a soft towel. Do NOT allow the edges of the mirror to get or remain wet over a period of time. Please do NOT use glass cleaner that contains ammonia or vinegar. Never spray any cleaner directly onto a mirror. Instead apply the cleaner to a soft cloth and then wipe the mirror. Make sure no commercial cleaner comes in contact with the edge or backing.

## WARRANTY

### 5 years Limited Warranty

**innoci usa** LED mirrors (Illumirror®) have been manufactured under the highest standards of quality and workmanship. We warrant to the original purchaser that our LED mirrors are free from any defects in material and workmanship by normal use for 5 years from date of purchase. A replacement for any defective part will be supplied FREE OF CHARGE for installation by you.

This warranty is valid to the original purchaser only and does not cover product damage due to installation error, product abuse, product misuse, etc. whether or not performed by professionals. **innoci usa** will not be responsible for labor charges and/or damage incurred in installation, repair or replacement nor for any incidental or consequential damages.

All warranty claims should be sent to [customerservice@innoci-usa.com](mailto:customerservice@innoci-usa.com) or call 1.866.479.8076. Our customer service representative will contact you promptly to help you go through the process until you are completely satisfied with our products.

**SHORTAGE OR DAMAGED PRODUCTS** All shipments are carefully inspected and counted before leaving our distribution centers. Please inspect carefully on receipt of merchandise, noting any discrepancy or damage on the carrier's freight bill at that time, and file a claim with the carrier within 10 days from receipt of order. Then contact our office. Deductions from invoices for shortages or damage claims will not be allowed.

**RETURN NEW GOODS** All claims for returns or adjustments must have prior approval and return authorization (RA) number. Only original, sealed product in salable condition are eligible for return. Credit for authorized returns will be issued at the net price paid for the product and subject to a 15% restocking/handling fee. Merchandise is to be returned via prepaid freight. All unauthorized returns will be refused or subject to a 25% restocking/handling fee.

To request an "RA" number: Contact our Customer Service Representatives at [customerservice@innoci-usa.com](mailto:customerservice@innoci-usa.com). We will send you a Return Authorization Number (RA) by return email. Please take necessary precautions when returning merchandise to prevent additional damage. Insurance is the responsibility of the shipper.

# Exploded view

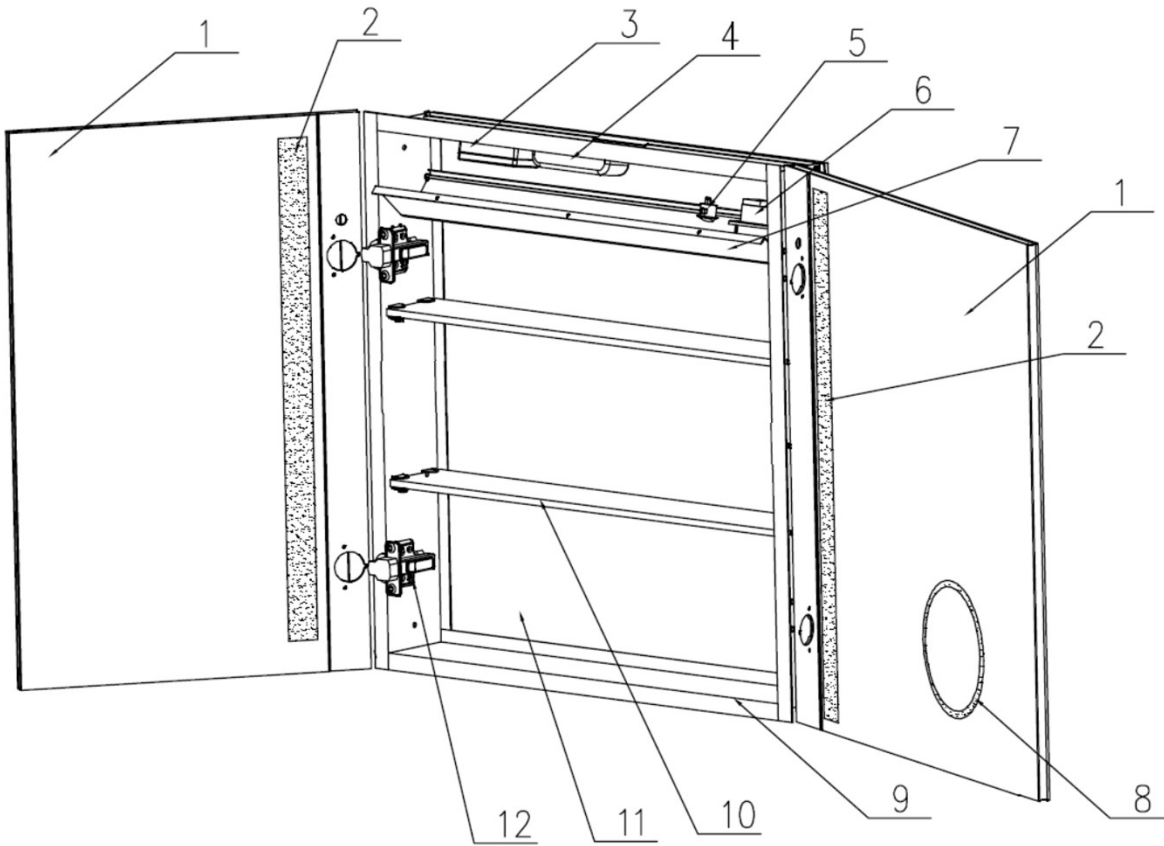

Part	Description
1	Mirror Door
2	LED Light
3	Connection Box
4	LED Driver
5	Rocker Switch
6	110V Outlet
7	Cover Plate
8	Cosmetic Mirror
9	Aluminum Frame
10	Glass Shelf
11	Mirror Back Board
12	Hinge

**innoci usa, Inc.**

14530 Best Ave.,  
Santa Fe Springs, CA 90670

[www.innoci-usa.com](http://www.innoci-usa.com)