



## TRADITIONAL CONSTRUCTION

*Enjoy the warmth and beauty of exterior wood shutters. Our wood shutters are hand crafted from the most popular wood species and can be clear coated, stained, or painted.*

*Each joint is joined with two wood dowels and glued with polyurethane exterior glue. A 3 ½" treated screw is then inserted, countersunk then plugged and sanded smooth.*

## AUTHENTIC MATERIALS

*We use only the finest species for construction of beautiful wood shutters. Available in Pine, Cedar, Redwood, and Mahogany. For painted panel shutters, we offer them available with Extria panels to give you the look of an authentic painted wood shutter, but with the durability of advanced, maintenance free, materials.*

## BEAUTIFUL FINISHES



BLACK

CHROME GREEN

COTTAGE RED

DARK GREEN

COUNTRY  
REDWOOD

TUDOR BROWN

WHITE

PRIMED

UNFINISHED

# LOUVER SHUTTERS

Louvered Window Shutters offer tasteful signature styling and a timeless accent to homes. Imagine the graceful yet enduring beauty that these exterior shutters can bring to your home. Choose from one of our many louver combinations. Custom made in a variety of sizes and lengths.



## SHUTTER DIMENSIONS

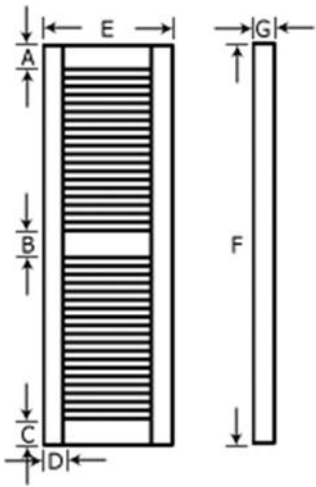

	PINE	CEDAR	REDWOOD	MAHOGANY
Louver Angle	17°	17°	17°	17°
Louver Spacing	1 ¾"	1 ½"	1 ½"	1 ½"
Louver Size	¼" x 1 ¾"	¼" x 1 ½"	¼" x 1 ½"	¼" x 1 ½"
Top Rail A	3"	3"	3"	3"
Center Rail B	3"	3"	3"	3"
Bottom Rail C	3" to 5 ½"	3" to 5 ½"	3" to 5 ½"	3" to 5 ½"
Stiles D	2 ½"	2 ½"	2 ½"	2 ½"
Width E	9" to 36"*	9" to 36"*	9" to 36"*	9" to 36"*
Height F	15" to 150"*	15" to 150"*	15" to 150"*	15" to 150"*
Thickness G	1"	1 ½"	1 ½"	1 ½"

\*Available in ½" increments.

# RAISED PANEL SHUTTERS

Raised Panel Shutters add that traditional colonial look. With a traditional 2 panel to custom 3 panel shutters, our extensive selection will surely fit your needs.



SINGLE



EQUAL



OFFSET



THREE EQUAL



SMALL TOP



SMALL CENTER

## SHUTTER DIMENSIONS

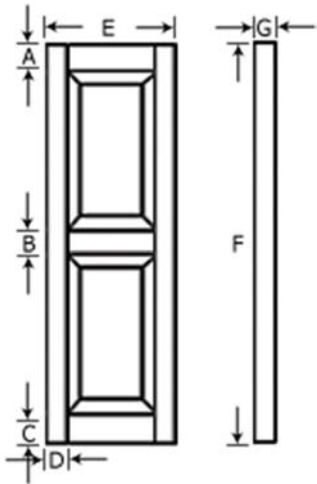

	PINE	CEDAR	REDWOOD	MAHOGANY	COMPOSITE
Top Rail A	3"	3"	3"	3"	3"
Center Rail B	3"	3"	3"	3"	3"
Bottom Rail C	3" to 5 1/2"	3" to 5 1/2"	3" to 5 1/2"	3" to 5 1/2"	3" to 5 1/2"
Stiles D	2 1/8"	2 1/8"	2 1/8"	2 1/8"	2 1/8"
Width E	9" to 36"*	9" to 36"*	9" to 36"*	9" to 36"*	9" to 36"*
Height F	15" to 150"*	15" to 150"*	15" to 150"*	15" to 150"*	15" to 150"*
Thickness G	1"	1 1/2"	1 1/2"	1 1/2"	**

\*Available in 1/8" increments.

\*\*Composite panels are available for use on all species. Dimensions will be the same as selected species.

# BOARD-N-BATTEN SHUTTERS

*In its simplest form, the Board-n-Batten shutter has been rumored to be the first style of shutter invented. The vertical members are referred to as the boards and the horizontal members are referred to as the battens. This classic style is perfect for ranch style homes or homes that want to reflect historical significance and simplicity.*



TWO BATTEN



THREE BATTEN



Z-BOARD



ARCH TOP

## SHUTTER DIMENSIONS

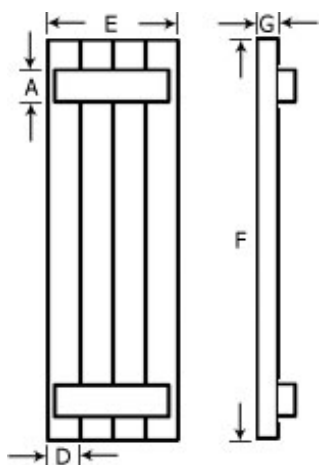

	<b>PINE</b>	<b>CEDAR</b>	<b>REDWOOD</b>	<b>MAHOGANY</b>
Cross Battens A	1" x 3 1/2"	1" x 3 1/2"	1" x 3 1/2"	1" x 3 1/2"
Board Width D	Varies	Varies	Varies	Varies
Width E	9" to 36"*	9" to 36"*	9" to 36"*	9" to 36"*
Height F	15" to 150"*	15" to 150"*	15" to 150"*	15" to 150"*
Thickness G	1"	1"	1"	1"
Thickness Total	2"	2"	2"	2"

\*Available in 1/8" increments.

# COMBINATION SHUTTERS

The Combination Shutter originated in the New Orleans area with its unique combination of both louver and raised panel. It offers the beauty of both styles, yet offers a second glance appeal to traditional styles. You can mix and match your styles with a variety of louver and raised panel combinations to make your own unique look.



LOUVER/PANEL



PANEL/LOUVER



PANEL/LOUVER/PANEL



60-40 LOUVER/PANEL



60-40 PANEL/LOUVER

## SHUTTER DIMENSIONS

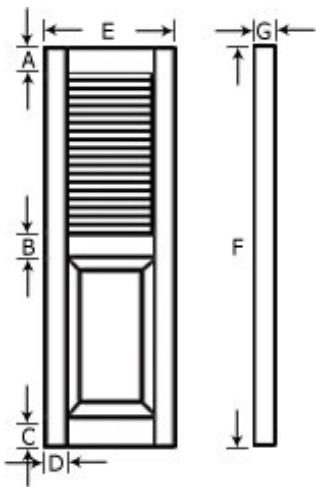

	PINE	CEDAR	REDWOOD	MAHOGANY	COMPOSITE
Louver Angle	17°	17°	17°	17°	17°
Louver Spacing	1 3/4"	1 1/2"	1 1/2"	1 1/2"	1 1/2"
Louver Size	1/4" x 1 3/4"	1/4" x 1 1/2"	1/4" x 1 1/2"	1/4" x 1 1/2"	**
Top Rail A	3"	3"	3"	3"	3"
Center Rail B	3"	3"	3"	3"	3"
Bottom Rail C	3" to 5 1/2"	3" to 5 1/2"	3" to 5 1/2"	3" to 5 1/2"	3" to 5 1/2"
Stiles D	2 1/8"	2 1/8"	2 1/8"	2 1/8"	2 1/8"
Width E	9" to 36"*	9" to 36"*	9" to 36"*	9" to 36"*	9" to 36"*
Height F	15" to 150"*	15" to 150"*	15" to 150"*	15" to 150"*	15" to 150"*
Thickness G	1"	1 1/2"	1 1/2"	1 1/2"	**

\*Available in 1/8" increments.

\*\*Composite panels are available for use on all species. Dimensions will be the same as selected species.

# FLAT PANEL SHUTTERS

Flat panel shutters are inspired after the Shaker design where clean lines and simplicity define style. These shutters are perfect for Arts & Crafts or Craftsman style homes. Like all our wood shutters, these shutters are hand crafted and assembled for authenticity and architectural correctness.



SINGLE



EQUAL



OFFSET



THREE EQUAL



SMALL TOP



SMALL CENTER

## SHUTTER DIMENSIONS

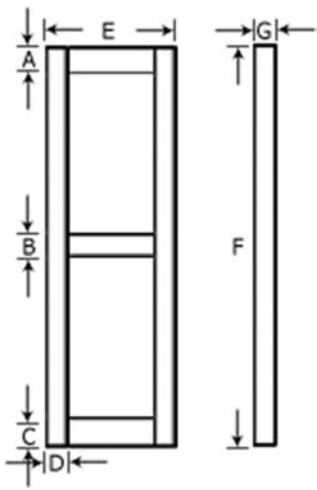

	PINE	CEDAR	REDWOOD	MAHOGANY	COMPOSITE
Top Rail A	3"	3"	3"	3"	3"
Center Rail B	3"	3"	3"	3"	3"
Bottom Rail C	3" to 5 1/2"	3" to 5 1/2"	3" to 5 1/2"	3" to 5 1/2"	3" to 5 1/2"
Stiles D	2 1/8"	2 1/8"	2 1/8"	2 1/8"	2 1/8"
Width E	9" to 36"*	9" to 36"*	9" to 36"*	9" to 36"*	9" to 36"*
Height F	15" to 150"*	15" to 150"*	15" to 150"*	15" to 150"*	15" to 150"*
Thickness G	1"	1 1/2"	1 1/2"	1 1/2"	**

\*Available in 1/8" increments.

\*\*Composite panels are available for use on all species. Dimensions will be the same as selected species.

# BAHAMA SHUTTERS

Inspired by the traditional Caribbean design, Bahama shutters provide a bold accent with smart functionality. Attached to the exterior with a top hinge, the shutters can swing out at the bottom, letting breezes and sunlight bathe the space. When the shutters are closed, open louvers reduce the sun's hot rays and enhance privacy while still allowing air to circulate.



STANDARD

w/HORIZONTAL

## Examples of Common Installation Options - Bahama Hardware

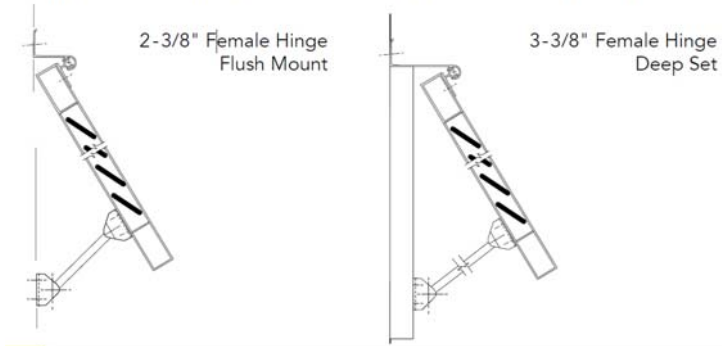

## SHUTTER DIMENSIONS

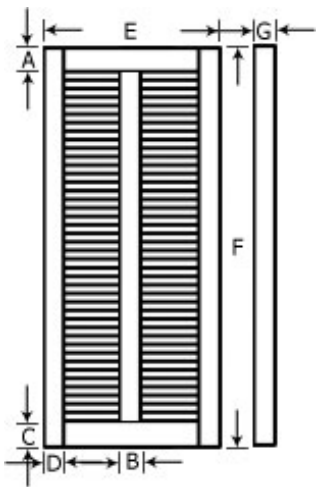

	PINE	CEDAR	REDWOOD	MAHOGANY
Louver Angle	17°	17°	17°	17°
Louver Spacing	1 3/4"	1 1/2"	1 1/2"	1 1/2"
Louver Size	1/4" x 1 3/4"	1/4" x 1 1/2"	1/4" x 1 1/2"	1/4" x 1 1/2"
Top Rail A	3"	3"	3"	3"
Bottom Rail C	3" to 5 1/2"	3" to 5 1/2"	3" to 5 1/2"	3" to 5 1/2"
Stiles B & D	2 1/8"	2 1/8"	2 1/8"	2 1/8"
Width E	10" to 120"*	10" to 120"*	10" to 120"*	10" to 120"*
Height F	15" to 150"*	15" to 150"*	15" to 150"*	15" to 150"*
Thickness G	1"	1 1/2"	1 1/2"	1 1/2"

\*Available in 1/4" increments.  
Vertical Stiles (or mullions) are recommended every 30".

# SHUTTER OPTIONS

Add a unique look to your shutters that will help them really stand out. Choose from one of our most popular shapes, or give us a call if you have your own design in mind.



**None (No Cutout)**  
Factory Shutter Cutout



**Anchor**  
Factory Shutter Cutout



**Diamond**  
Factory Shutter Cutout



**Heart**  
Factory Shutter Cutout



**Moon**  
Factory Shutter Cutout

Have a design you would like to see? We can do it.  
Custom designs available.



**Palm Tree**  
Factory Shutter Cutout

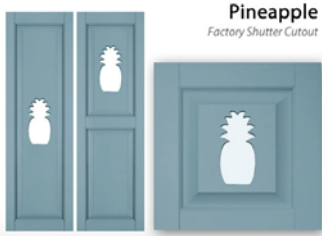

**Pineapple**  
Factory Shutter Cutout



**Sailboat**  
Factory Shutter Cutout



**Star**  
Factory Shutter Cutout



**Tree**  
Factory Shutter Cutout

# SHUTTER HARDWARE

Complete your shutter installation with beautiful shutter hardware. Our shutter hardware is available for both decorative and functional shutter applications. Here are a view examples available in a variety of sizes.



L-HINGE



STRAP-HINGE



FLAT HINGE



SHUTTER HOLDBACKS



SLIDE BOLT



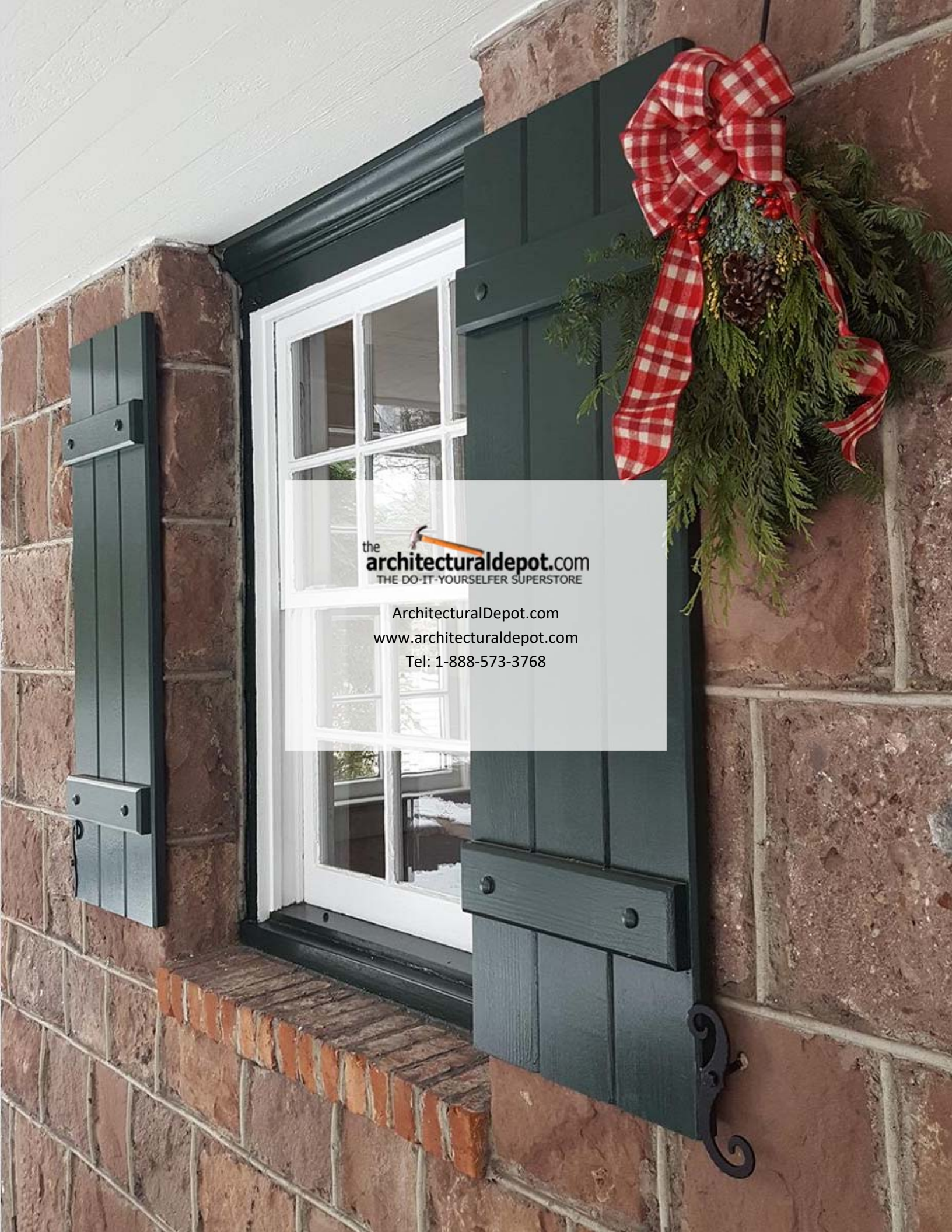

the  
**architecturaldepot.com**  
THE DO-IT-YOURSELF SUPERSTORE

ArchitecturalDepot.com  
[www.architecturaldepot.com](http://www.architecturaldepot.com)  
Tel: 1-888-573-3768