

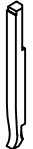

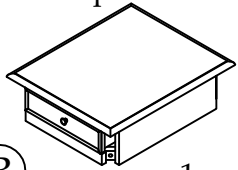

Components and Hardware List

<p>Leg</p>  <p>(A) 4 pcs.</p>	<p>Table Top</p>  <p>(B) 1 pc.</p>	<p>Shelf</p>  <p>(C) 1 pc.</p>	<p>L-Bracket</p>  <p>(D) 4 pcs.</p>
<p>M5/16"-18 x 2-1/4" Long Allen Head Bolt</p>  <p>(E) 4 pcs.</p>	<p>M5/16"-18 x 5/8" Allen Head Bolt</p>  <p>(F) 8 pcs.</p>	<p>5/16" Spring Washer</p>  <p>(G) 12 pcs.</p>	<p>5/16" *19*2mm Flat Washer</p>  <p>(H) 12 pcs.</p>
<p>5mm Allen Wrench</p>  <p>(I) 1 pc.</p>			

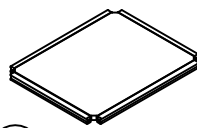

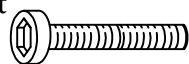
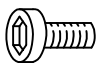
#51709

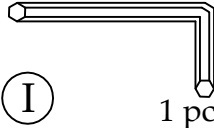
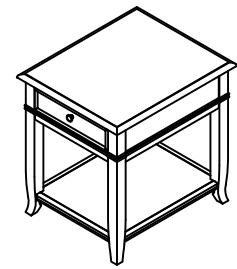
End Table

Be sure to check all packing material carefully for small parts, which may have come loose inside the carton during shipment.

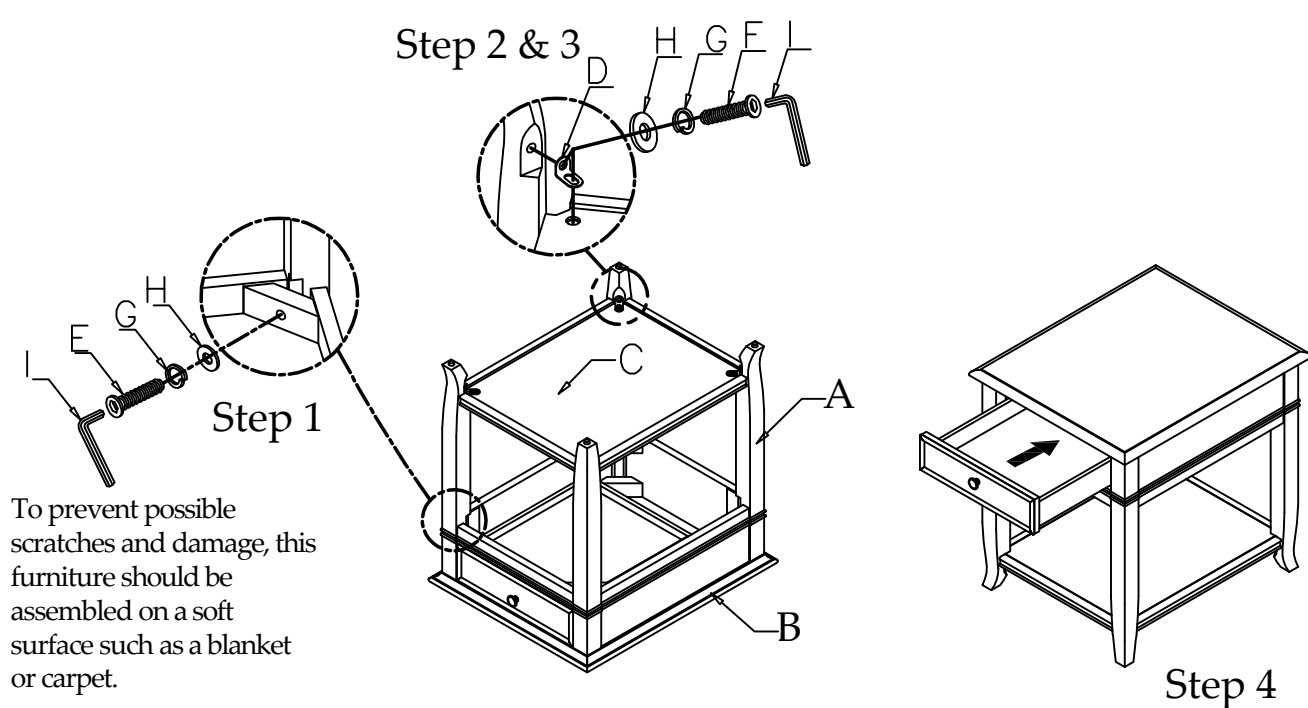

To prevent possible scratches and damage, this furniture should be assembled on a soft surface such as a blanket or carpet.

- Step 1: Place the Table Top upside down. Attach three Legs (A) into corners of the Table Top using the Long Allen Head Bolts (E), Spring Washers (G) and Flat Washers (H). Do not fully tighten until after Step 3.
- Step 2: Position the Shelf (C) into the notches of the three Legs already attached. Position the fourth Leg into the corner of the Table Top and Shelf. Attach the leg to the table top using the same Bolts and Washers as in previous step.
- Step 3: Attach the Shelf to the Legs using the L-Brackets (D) and the Long Bolts (F), Spring Washers (G) and Flat Washers (H). While pulling the Legs into the notch, tighten the Bolts with the Allen Wrench (I).
- Step 4: Carefully set the completed Table upright.