

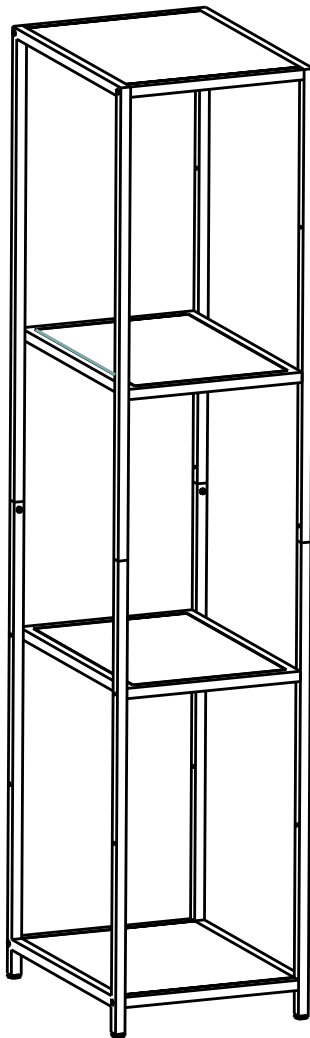

OWNER'S MANUAL



**TRINITY 4-TIER 15" X 20" X 72" BAMBOO SHELVING
- BRONZE ANTHRACITE
Model # TBFPA-2703**

PARTS LIST

Your TRINITY 4-Tier 15" x 20" x 72" Bamboo Shelving should include the following parts. Please inspect box contents to ensure you have received all components.

If you are missing any parts, need assistance with assembly or have questions, please contact TRINITY Customer Service: 800.985.5506 or customerservice@trinityii.com. Parts can also be requested online at www.trinityii.com (Help & More, Contact Us).

A

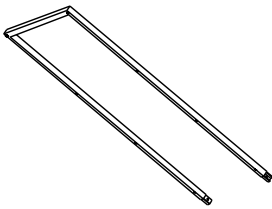

**TOP SIDE
FRAME (2)**

B

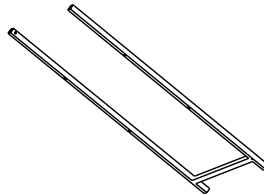

**BOTTOM SIDE
FRAME (2)**

C

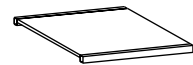

**FIXED SHELF
(2)**

D

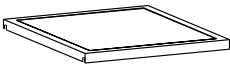

**ADJUSTABLE SHELF
(2)**

E



SCREW (8)

F



**FRAME
CONNECTING
SCREW (4)**

G



**ADJUSTABLE
SHELF REST (8)**

H

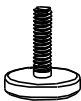

**FEET
LEVELER (4)**

I



HEX KEY (1)

J

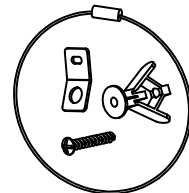

**ANTI-TIPPING
KIT (2)**

ASSEMBLY INSTRUCTIONS

STEP 1

Screw FEET LEVELERS (H) into the bottoms of each BOTTOM SIDE FRAME (B). Turn clockwise to screw in place.

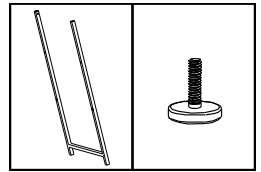

B (2)

H (4)

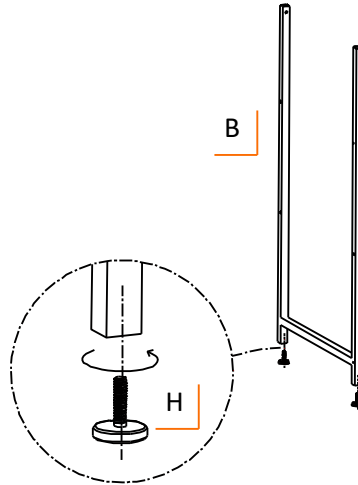

STEP 2

Connect TOP SIDE FRAME (A) to BOTTOM SIDE FRAME (B). Using the included HEX KEY (I), screw 1 FRAME CONNECTING SCREW (F) into each hole where BOTTOM SIDE FRAME (B) is connected with TOP SIDE FRAME (A). Repeat for remaining FRAME CONNECTING SCREWS (F).

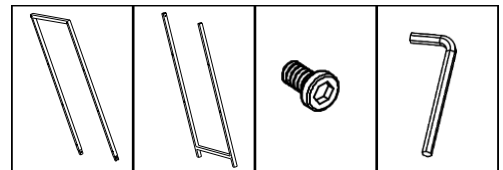

A (2)

B (2)

F (4)

I (1)

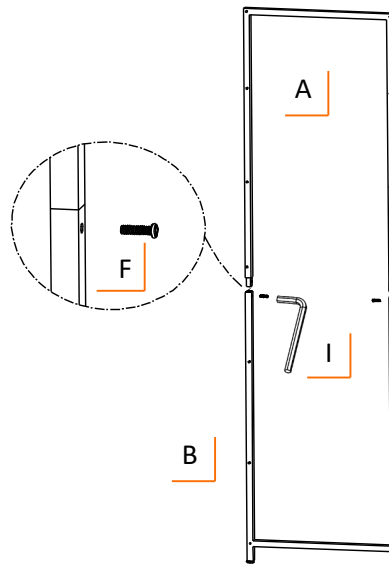

ASSEMBLY INSTRUCTIONS

STEP 3

Lay SIDE FRAMES (TOP + BOTTOM SIDE FRAMES assembled in Step 2) on its side.

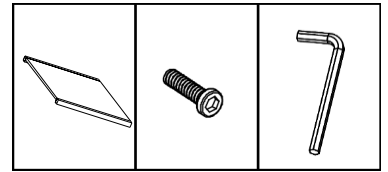

C (2)

E (8)

I (1)

Place FIXED SHELVES (C) on their sides and connect them to TOP & BOTTOM SIDE FRAMES (A & B). Tighten SCREWS (E) with HEX KEY (I).

Stand the unit upright.

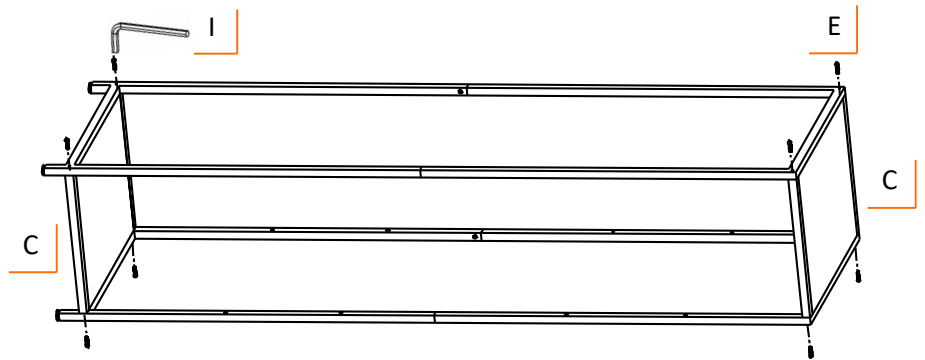

STEP 4

Tighten 4 ADJUSTABLE SHELF RESTS (G) into shelf frame by hand and make sure they are on the same level.

Do the same for the other 4 ADJUSTABLE SHELF RESTS (G).

Place 2 ADJUSTABLE SHELVES (D) on each set of ADJUSTABLE SHELF RESTS (G). Make sure the shelf notches are resting on ADJUSTABLE SHELF RESTS (G).

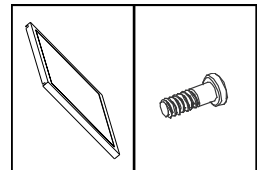
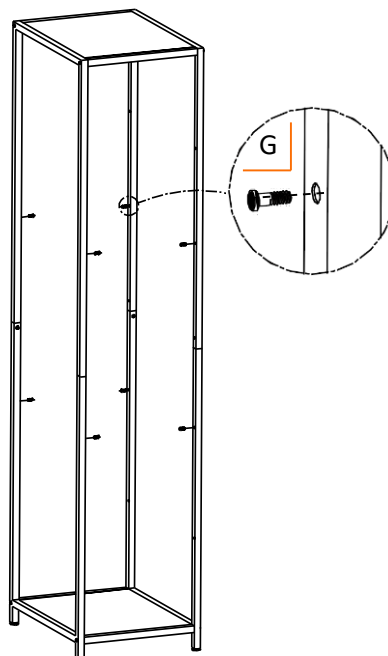

D (2)

G (8)

ASSEMBLY INSTRUCTIONS

STEP 5

To install the ANTI-TIPPING KIT (J), place 4-Tier Bamboo Shelving against the wall. Mount bracket to the wall, next to outer TOP SIDE FRAME (A) just below the top FIXED SHELF (C).

First, fully secure ANTI-TIPPING KIT (J) to the wall.

Next, close cable loop through TOP SIDE FRAME (A) as shown.

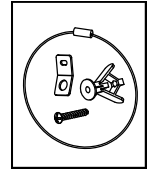

J (2)

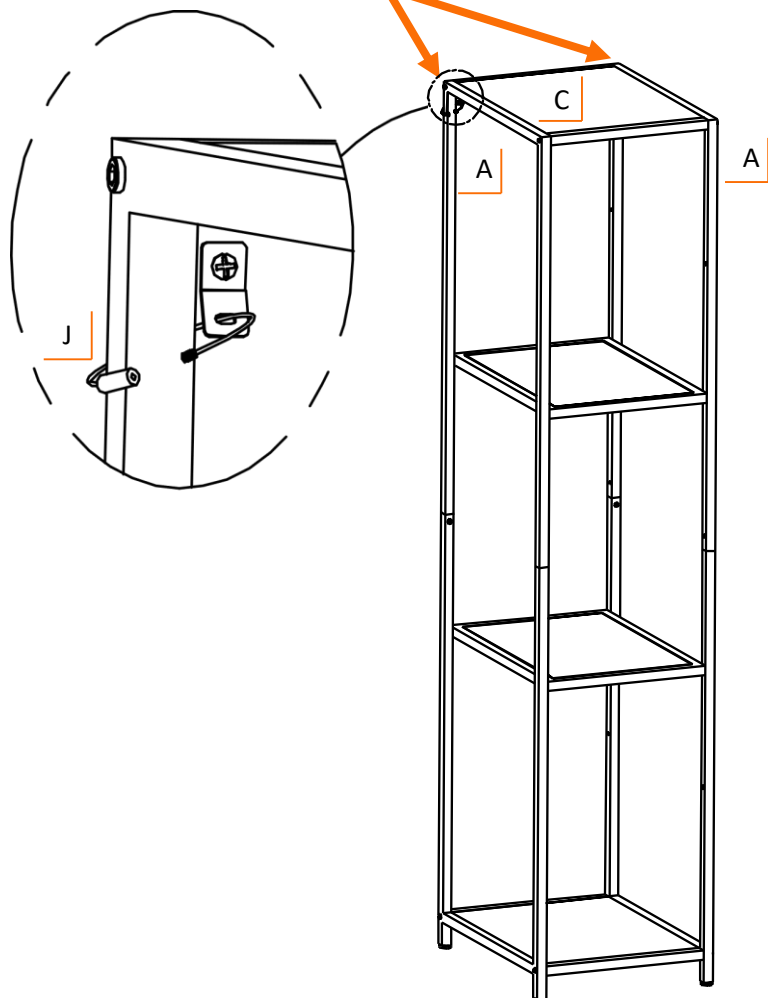
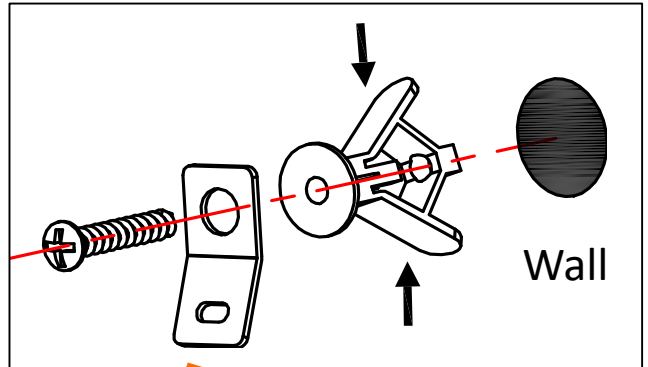

PRODUCT EXTRA SHELF OPTIONS

There are extra screw holes in this product for more ADJUSTABLE SHELVES. You will need 1 ADJUSTABLE SHELF and 4 ADJUSTABLE SHELF RESTS to add one extra shelf to the product.

Extra ADJUSTABLE SHELVES (PRA-03-046-1320) and ADJUSTABLE SHELF RESTS (ZBK-01-031-0620) are available for purchase. Please visit our website www.trinityii.com or contact our Customer Service (see last page of the manual) to place your order.

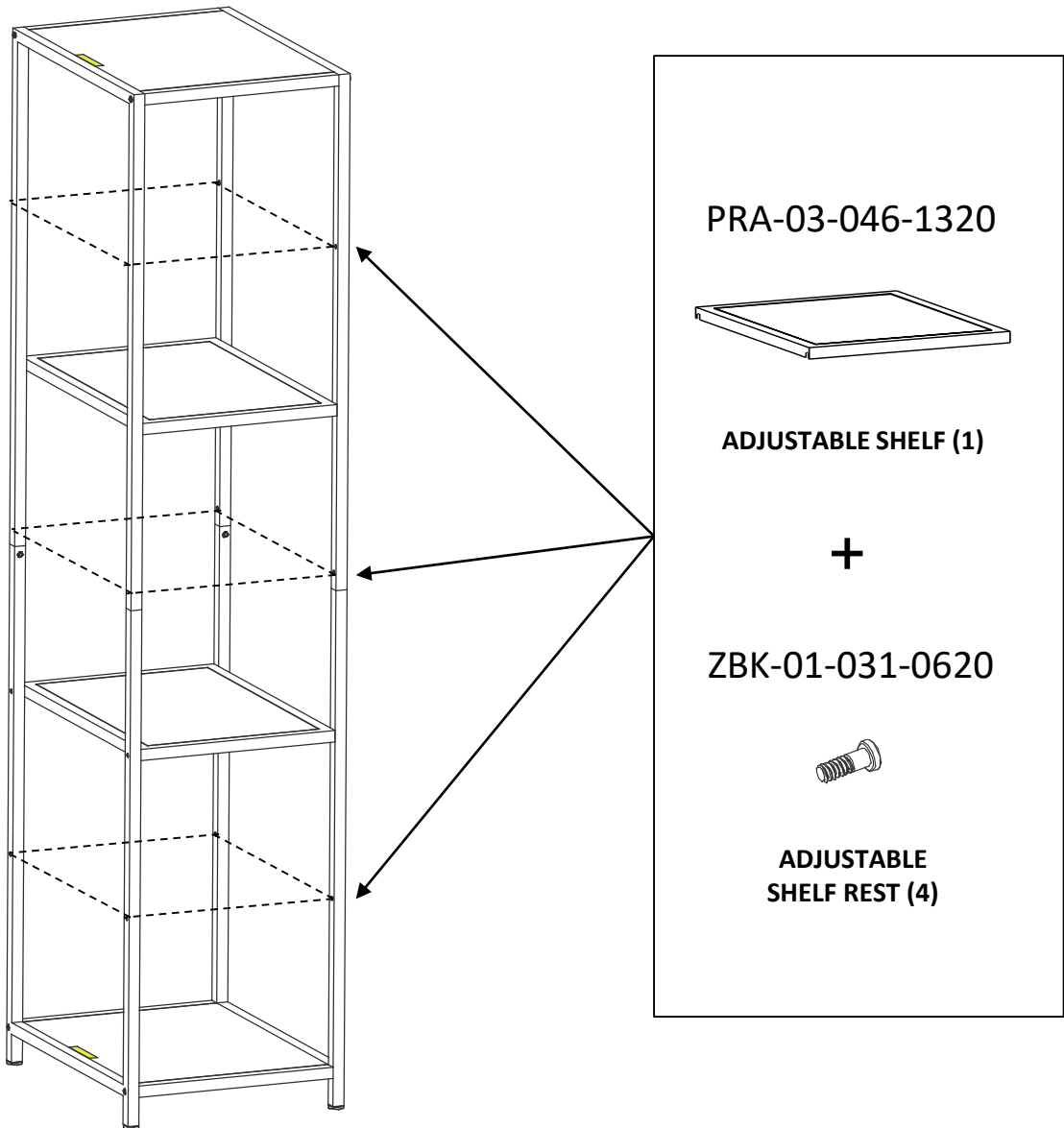

SERVICE PARTS LIST – TBF PRA-2703

TRINITY Customer Service provides the following replacement parts:

Part Number	Description	Part Number	Description
1) XSV-02-011-0007	Anti-tipping kit	6) ZBK-01-002-0635	Screw
2) PRA-14-019-2036	Top Side Frame	7) ZBK-01-031-0620	Adjustable Shelf Rest
3) ZBK-01-002-0615	Frame Connecting Screw	8) PRA-03-046-1320	Adjustable Shelf
4) PRA-14-020-2036	Bottom Side Frame	9) PRA-03-045-1320	Fixed Shelf
5) XBK-98-006-2525	Feet leveler	10) XXX-97-001-0001	Hex Key

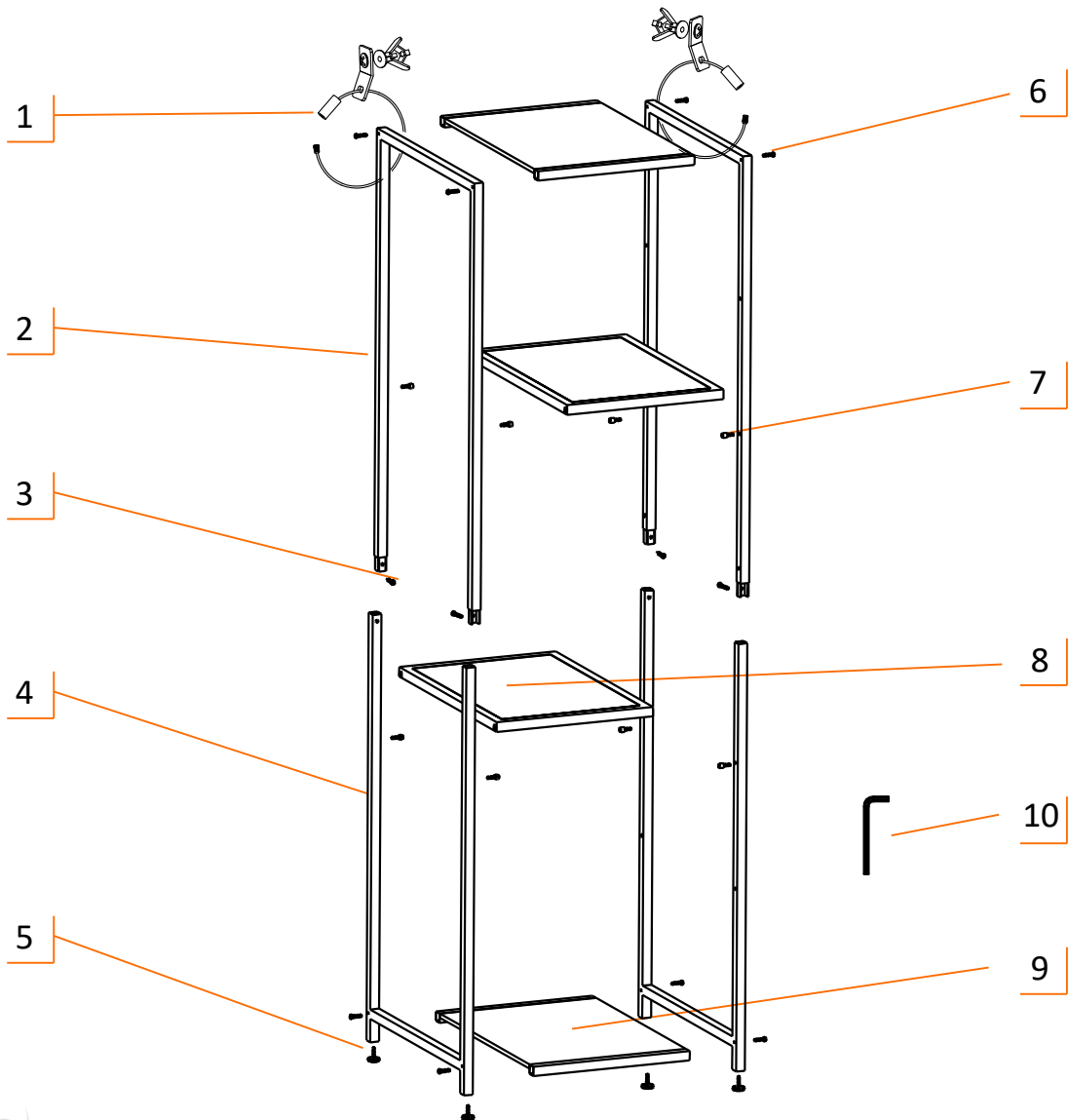

WARNINGS

1. **Read and understand all instructions.** Failure to follow all instructions may result in injury and/or damage.
2. **Use the provided anti-tipping kits to secure the product to the wall to prevent the product from tipping over.**
3. **The warnings, cautions, and instructions discussed in this manual cannot cover all possible conditions or situations that may occur.** The user must always be aware of their environment and ensure that they use the product in a safe and responsible manner.
4. **Do NOT modify the product in any way.** Unauthorized modification may impair the function and/or safety of the product, and may affect the life of the product.
5. **Check for damaged parts.** Before using this product, carefully check that all parts are in good condition, and that the product will operate properly and perform its intended function. Check for damaged parts and any other conditions that may affect the operation of this product. Replace damaged or worn parts, and never use this product with a damaged part.
6. **Do NOT overload the product.**

Weight capacity per shelf (evenly distributed)	50 lb
--	-------

7. **Do NOT allow children to climb or play around the product.**

CARE AND MAINTENANCE

- Bamboo can be maintained with mineral oil for best results.
- Avoid harsh, abrasive cleaners, and other corrosive chemicals.
- The product is designed for indoor use. Wipe dry and keep out of direct sunlight.

1 YEAR LIMITED WARRANTY

TRINITY 4-Tier 15" x 20" x 72" Bamboo Shelving Model # TBFRA-2703

Trinity International Industries ("Trinity") warrants to the original consumer purchaser ("Purchaser") of the TRINITY 4-Tier 15" x 20" x 72" Bamboo Shelving ("Product") that each Product shall be free from defects in workmanship and materials for a period of 1 year from the date of original purchase. Trinity's obligation under this warranty shall be limited to repair or replacement of, or adequate compensation for the Product which shall not be greater than the amount of the purchase price of the Product, at the option of Trinity, during the warranty period. All replaced parts and Products become the property of Trinity and must be returned to Trinity.

This warranty excludes normal wear and tear of the Product and its parts or components, and damage arising from any of the following: negligent use or misuse of the Product, use contrary to this User's Manual, or alteration by anyone other than Trinity. The warranty period of 1 year shall not be extended or renewed by the repair or replacement of, or compensation for, the Product. Any warranty implied by applicable law is limited in duration to one year from the date of purchase and is subject to the same conditions and limitations as is provided for our express warranty.

Except as set forth herein, and to the extent of applicable there are no warranties on this Product either express or implied, and Trinity disclaims all warranties including, but not limited to, any implied warranties of merchantability, infringement or fitness for a particular purpose. No warranty or guarantee given by any person, firm, or corporation with respect to this product shall be binding on Trinity.

If your Product is defective or otherwise requires service or parts, please call TRINITY Customer Service toll-free at (800) 985-5506, between 5:00 a.m. and 5:00 p.m., PST. Please tell us which model you purchased, the date of the purchase, and the problem with your Product. A copy of your original purchase receipt must accompany your service request.

LIMITATION OF REMEDIES AND LIABILITY

Trinity (and its employees, officers, members, managers, affiliates and assigns) shall not be liable for any incidental, consequential, special, indirect, remote, special or punitive damages for breach of any warranty, express or implied, including, but not limited to, lost profits, lost savings, loss of anticipated benefits and attorneys' fees, which arise out of the purchase, use or inability to use the Product, whether arising out of contract, negligence, strict tort, product liability, or any other legal theory on which a claim is based. As noted above, to the extent damages are allowed by our express warranty or by applicable law, those damages may not exceed the purchase price paid for the Product. Without limiting the foregoing Purchaser assumes all risk and liability for loss, damage or injury to Purchaser and Purchaser's property and to others and their property arising out of the use, misuse, or inability to use this Product. This limited warranty shall not extend to anyone other than the original purchaser of this product, is nontransferable and states your exclusive remedy.

Some states do not allow the exclusion or limitation of incidental, consequential, special, or punitive damages, so the above limitation or exclusion may not apply to you. The above warranty gives you specific legal rights, and you may have other rights which vary from state to state.

CONTACT US

**QUESTIONS? NEED PARTS?
WE ARE HERE TO HELP!**

Please feel free to contact us. There are no questions too small, or any problems too big. We're committed to providing our customers with the highest level of service.

TRINITY Customer Service

TEL: 800.985.5506

FAX: 310.347.4134

EMAIL: customerservice@trinityii.com

**Monday through Friday
5:00 AM – 5:00 PM (PST)**

www.trinityii.com