

ASSEMBLY INSTRUCTION

E296-12S 33"W BOOKCASE

A Top Panel	B Bottom Panel	C Shelf	D Side Frame
			
1PC	1PC	4PCS	2PCS
E Cross Bar	F Bolt 1/4"*3/4"	G Allen Wrench 4MM	H Anti-Tipping HW
			
1PC	28PCS	1PC	2SETS

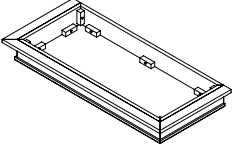
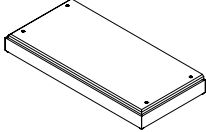
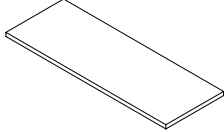
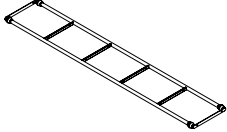
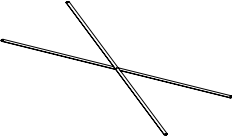
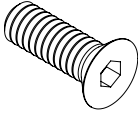
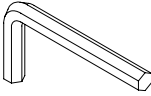
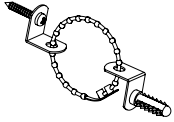
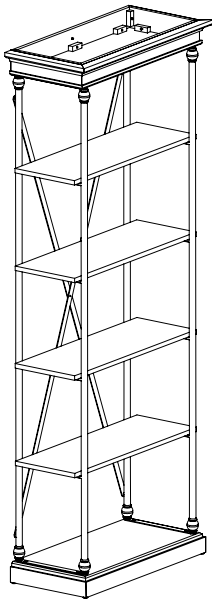

This page lists all the contents included in the box. Please take the time to identify the hardware as well as the individual components to this product. As you unpack and prepare for assembly, place the contents on a carpeted or padded area to protect them from damage.

***Do not tighten screws & bolts until the entire unit is completely assembled.

- 1 Assembly the Top Panel (A) and Bottom Panel (B) onto the Side Frame (D), then using the Bolt (F) by Allen Wrench (G).

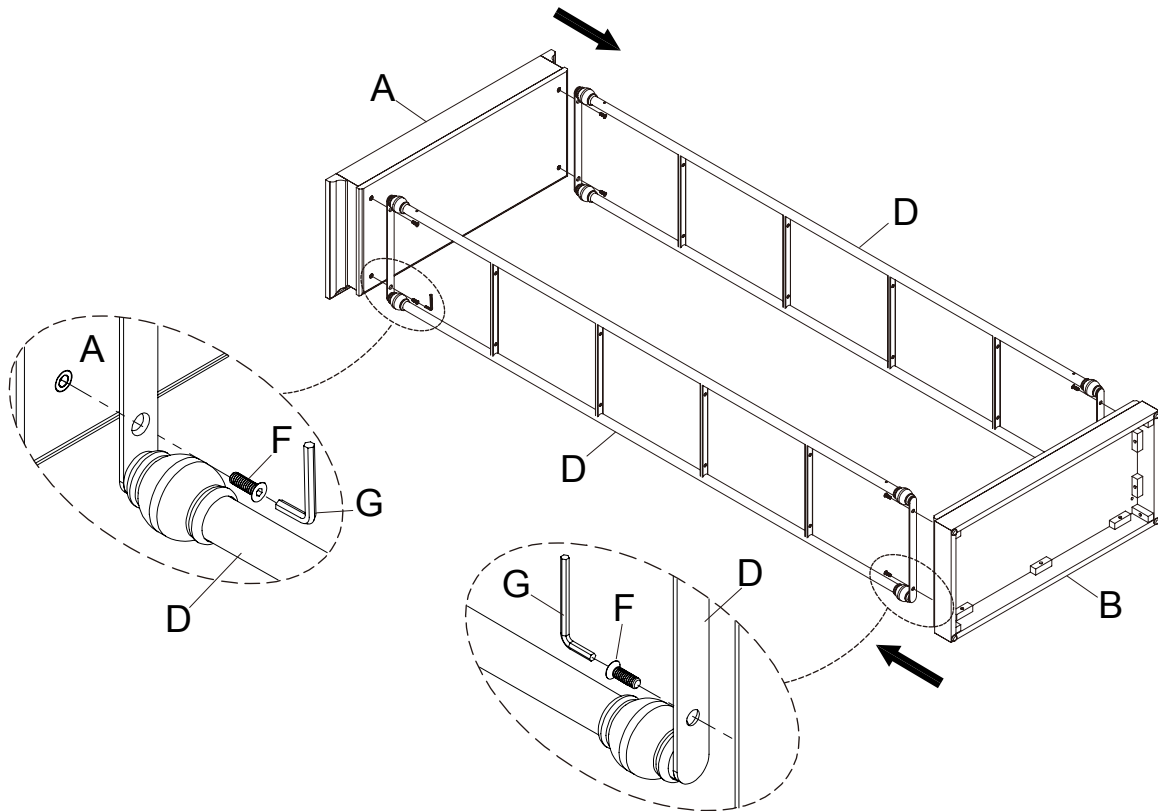

- 2 Assembly the Shelf (C) onto the Side Frame (D) and using the Bolt (F) by Allen Wrench (G).

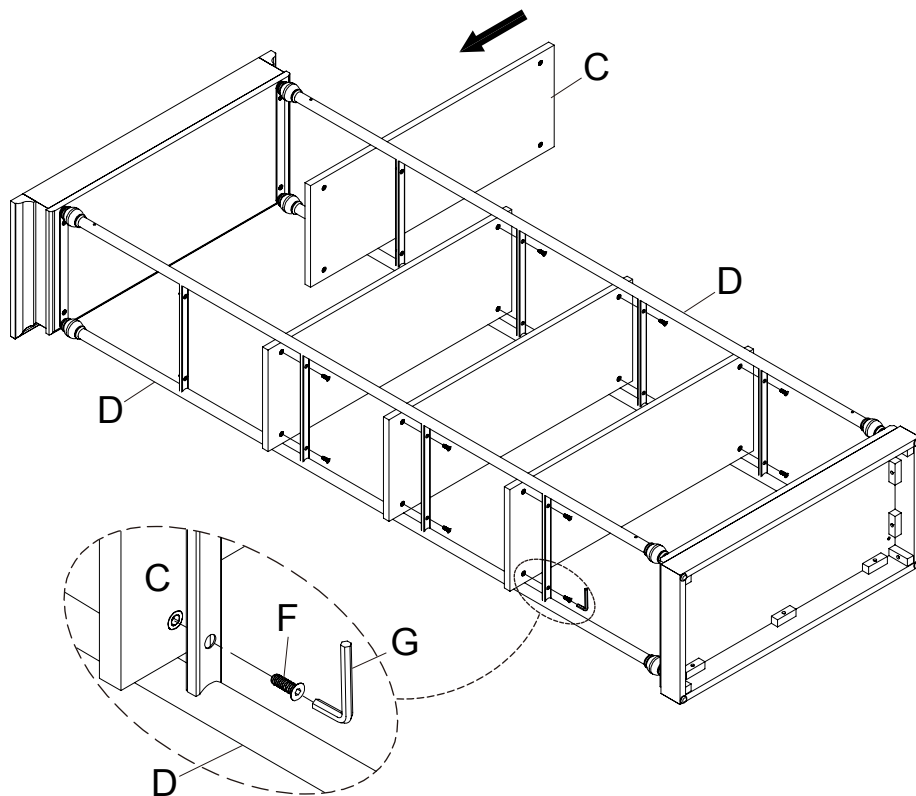

3

Assembly the Cross Bar (E) onto the Side Frame (D) and using the Bolt (F) by Allen Wrench (G).

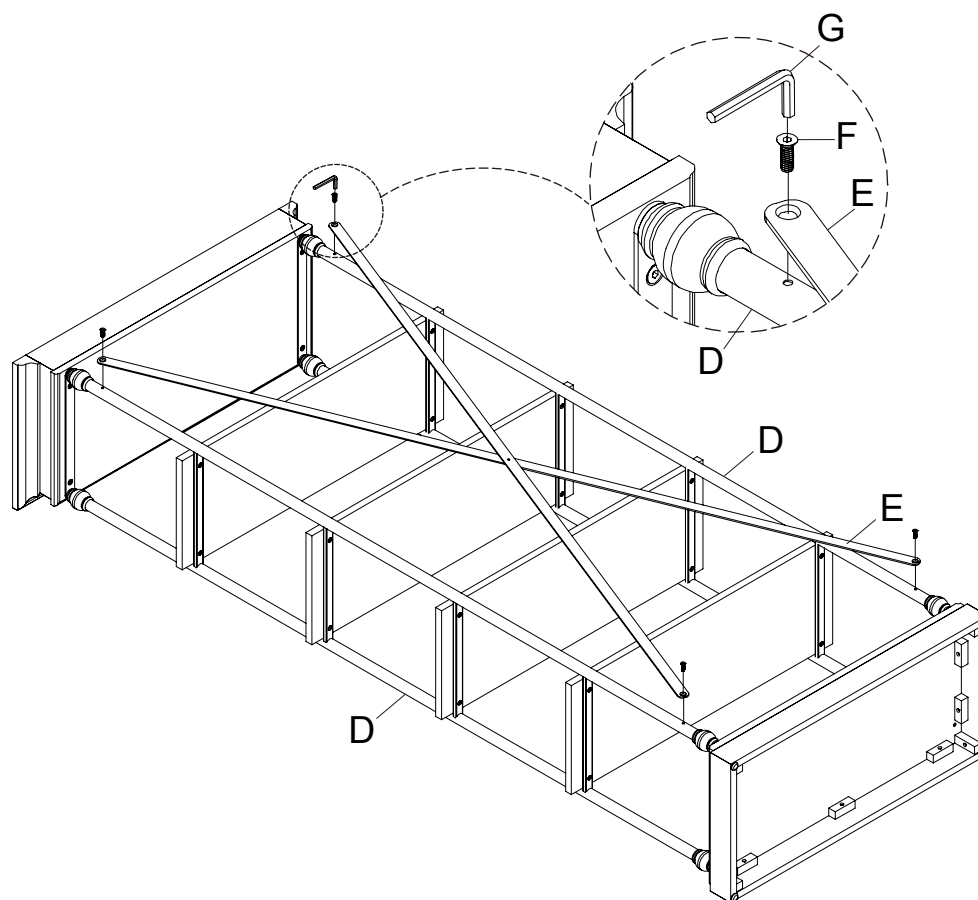

4

***NOTE: WE RECOMMEND THAT YOU ATTACH THE PRODUCT TO YOUR WALL AS A SAFETY PRECAUTION USING ANTI-TIPPING HW (H) AS BELOW INSTRUCTION.**

Attach Mounting Plate to the Top Panel (A) by using Wood Screw, make sure the Mounting Plate extend **DOWNWARD**.

Drill 2 holes in your wall approximately 2" (Inches) **BELOW** the corresponding positions of Mounting Plate and insert Wall Anchor as shown.

***NOTE:** You may need to tap **LIGHTLY** with a rubber mallet.

Now connect the corresponding Mounting Plate with Connection Strap and tighten as described before locking in place.

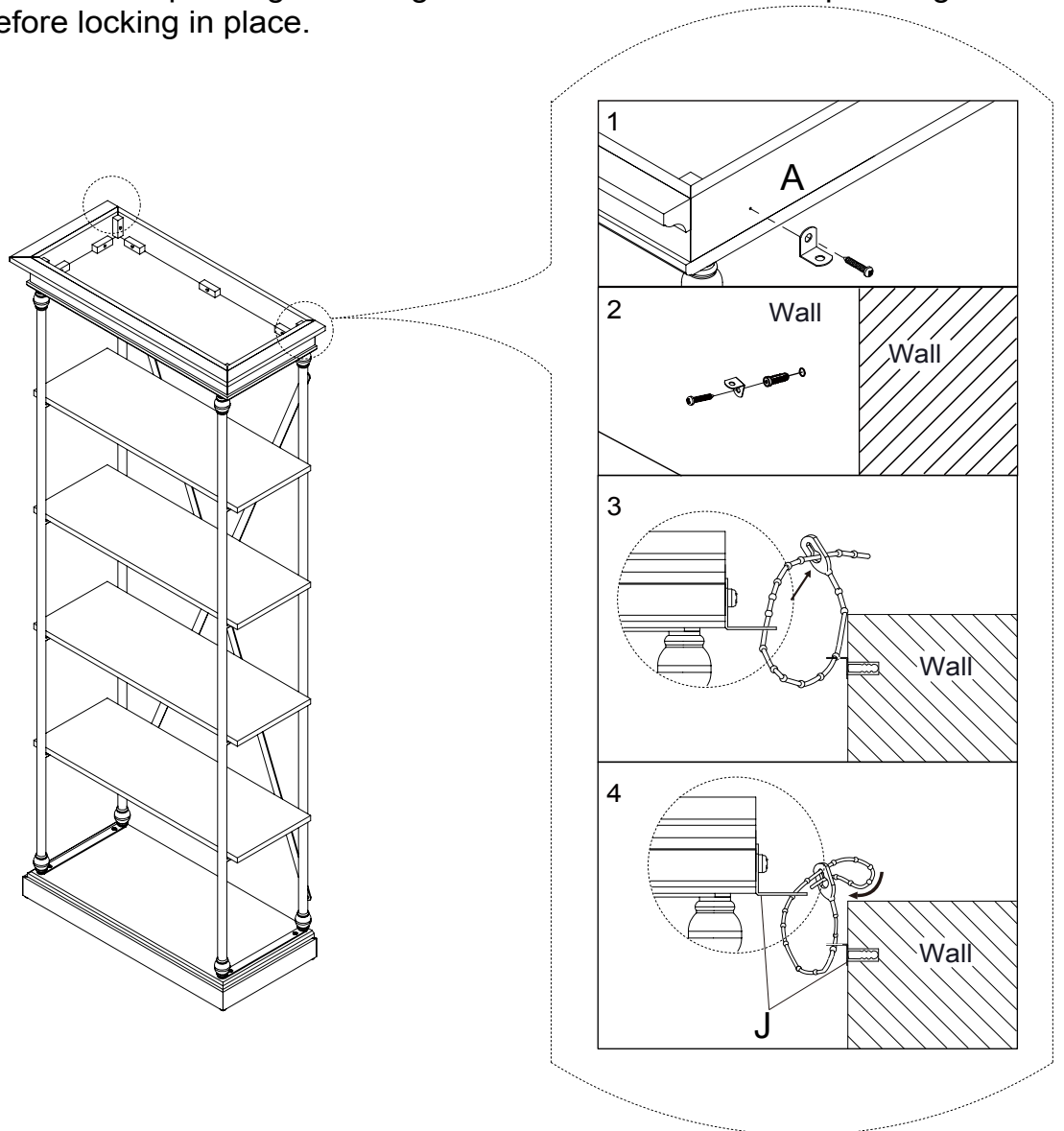

Cleaning & Care

Treat surface with care. Surface is resistant to scratches but is not scratch resistant. Clean surfaces with a dry or damp soft cloth. Do not use abrasive cleaners. Hardware may loosen over time. Periodically check that all connections are tight.