

www.technimobili.com

L-SHAPE OR STRAIGHT-LINE COMPUTER DESK

# MODEL RTA-3806

## ASSEMBLY INSTRUCTIONS

REV.OL-1-8023-0423

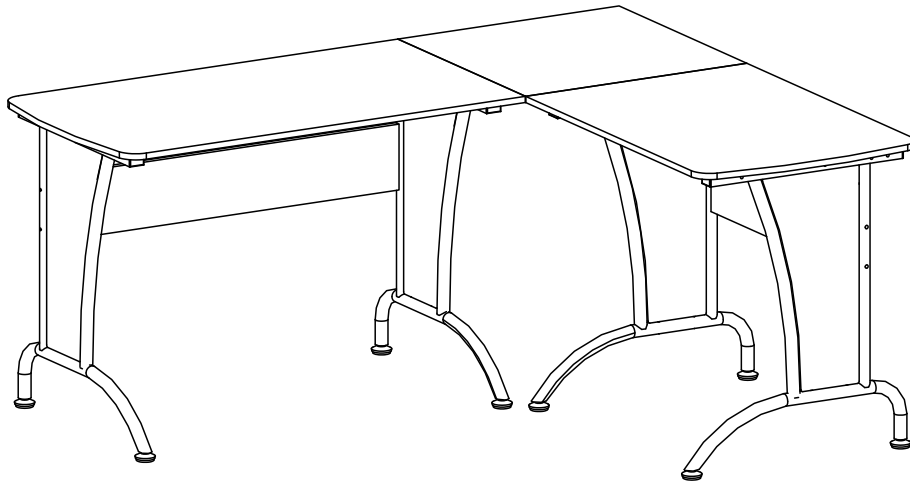

Thank you for purchasing our product



Do a quick inventory of all the parts and hardware listed below.



**For Support, assembly questions & Replacement Parts within the 48 Contiguous United States:**

Please email us at: [support@rtaproducts.com](mailto:support@rtaproducts.com)



Replacement Parts for International Customers & **AK-HI-PR** orders: RTA Products will replace the part free of charge, while **the customer is responsible for shipping costs plus any International local taxes or duties.**



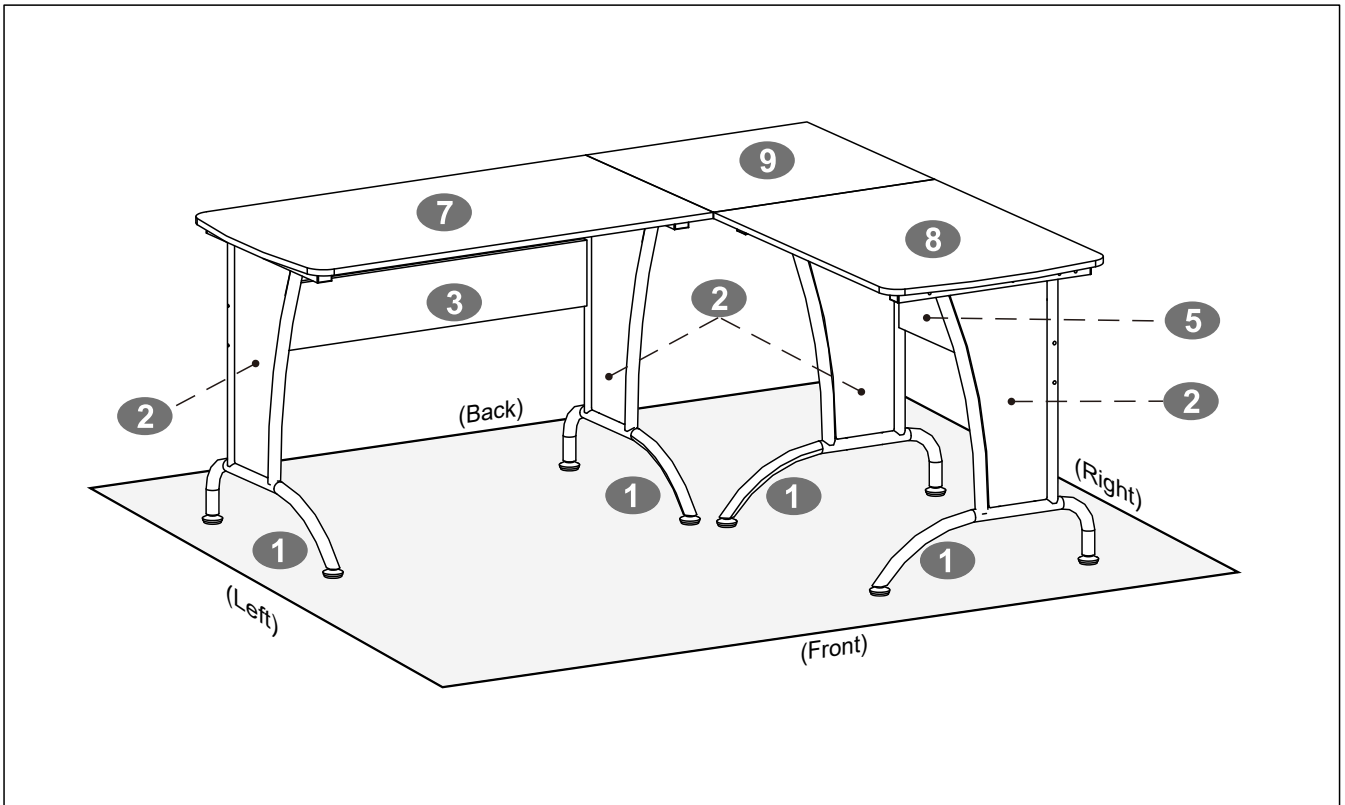

## MAIN PARTS LIST

<p><b>#1 Metal legs</b></p> <p>x4</p>	<p><b>#2 Side panels</b></p> <p>x4</p>	<p><b>#3 Long back panel</b></p> <p>37"</p>
<p><b>#5 Short back panel</b></p> <p>27"</p>		<p><b>#4 Long metal bar</b></p> <p>36.75"</p>
<p><b>#7 Long tabletop</b></p> <p>43.25"</p>		<p><b>#6 Short metal bar</b></p> <p>26.75"</p>
<p><b>#9 Middle tabletop</b></p> <p>24"</p>		<p><b>#8 Short tabletop</b></p> <p>35.5"</p>
<p><b>#11 Glide studs</b></p> <p>x8</p>		<p><b>#10 Middle metal support</b></p>
		<p><b>#12 Metal support brackets</b></p> <p>x4</p>

**MAIN PARTS LAYOUT (For reference)**

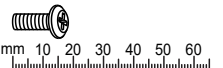

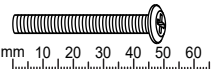
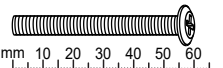
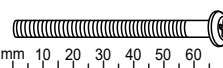
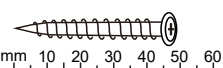
**HARDWARE LIST**

PART	QTY	SIZE / DESCRIPTION	ITEM
A	8	M6x12	
B	13	M6x35	
C	6	M6x45	
D	4	M6x55	
E	8	M6x65	
F	16	5x45mm	
G	4	M6	
H	8	M6, Ø10mm	

**INCLUDED TOOLS**

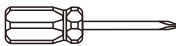
Phillips Screwdriver  

If you decide to use your own power driver:

- Make sure to have the appropriate Phillips bits.
- Start using at a low power or speed to avoid stripping the screws.

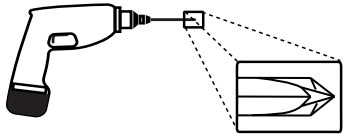
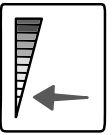
**BEFORE YOU START THE ASSEMBLY, PLEASE READ THE FOLLOWING TIPS AND WARNINGS.**

- Do not discard this manual or any of the packaging material until the unit is completely assembled.
- Please read the assembly instructions thoroughly and follow step by step.



- The assembly might require of 2 persons for certain steps. Before you start the installation, make sure there is someone else nearby to help you.



- Make sure you understand which hardware will be used on each step. Using the wrong size of screw, bolt or pin might strip the threads or cause damage to the part in which it is being used.

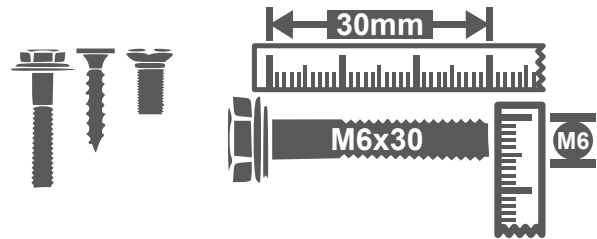

- To avoid misalignments, always leave the screws loosely and do not tighten them until all the pieces are positioned correctly.
- Do not overtighten or force the screws as they might break, strip, damage the threads of the holes, or get stuck inside the parts.

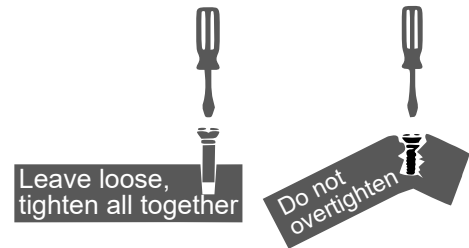

- If the hole seems to small for the screw, make sure you are using the correct size of screw and/or that you are installing it in the correct hole.



- Sometimes on the wood panels the laminate or material might be covering the hole partially or entirely, if there is no visible hole or if it looks too small, pass and press the tip of your finger over the area to feel its indentation, and carefully pierce the laminate to uncover the hole underneath.

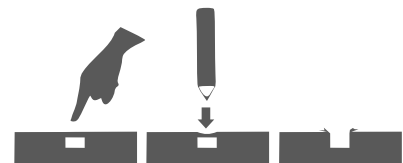

- Please be kind to our planet, when done with the assembly, recycle any of the packaging materials that is accepted by your city or recycling service.



Thank you!



## ASSEMBLY STEPS

WE RECOMMEND TO PLACE THE PIECES OVER BLANKETS OR TABLECLOTHS TO PROTECT THEIR FINISH DURING ASSEMBLY.

### STEP 1

Insert the glide studs #11 into the legs #1.

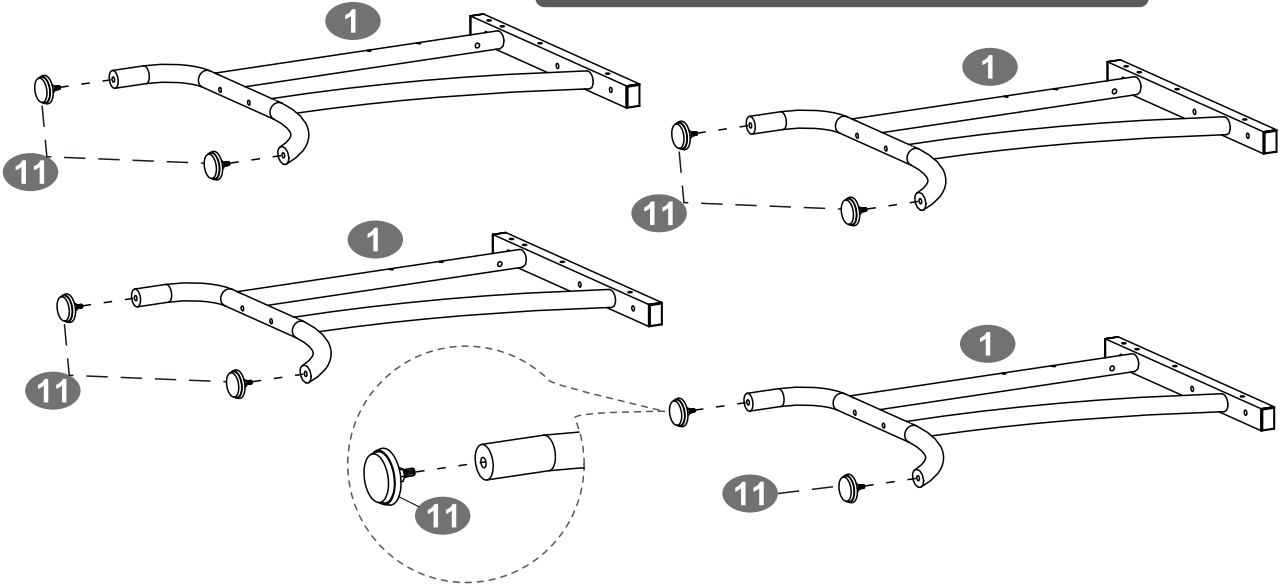

### STEP 2

#### Hardware

F  16 Pcs  
5x45mm

Tools (included)



Attach the side panels #2 to the legs #1 with screws F.

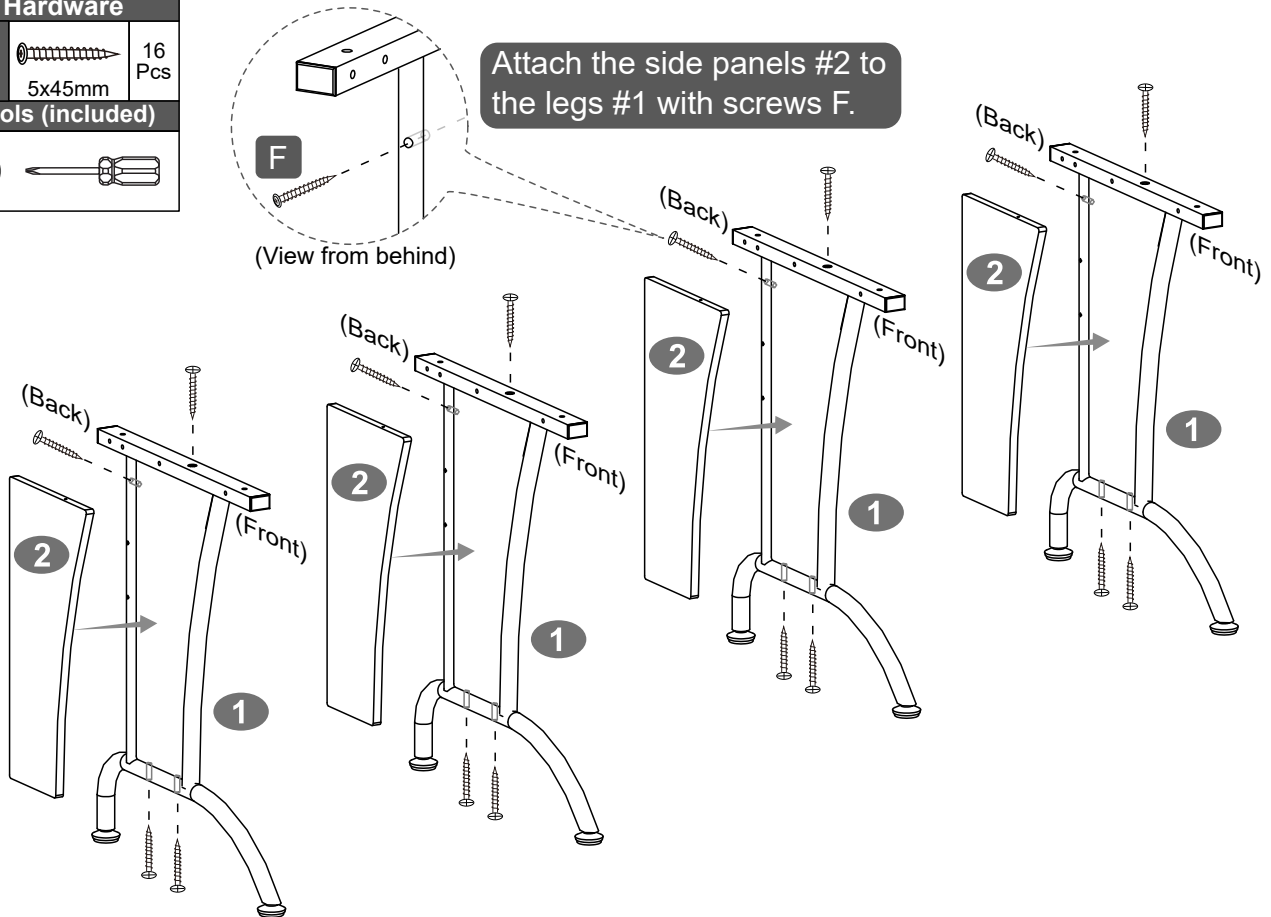

**STEP 3**

This step requires of 2 persons



**Hardware**

**E**  8 Pcs  
M6x65

**H**  8 Pcs  
M6, Ø10mm

**Tools (included)**



• **FIRST:** Assemble the back panels #3 and #5 in between the legs #1 with screws E and barrell nuts H.

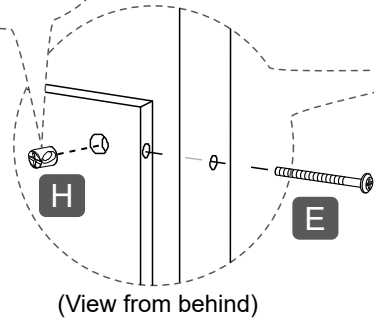
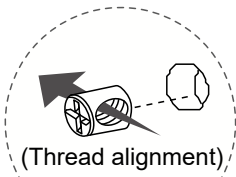
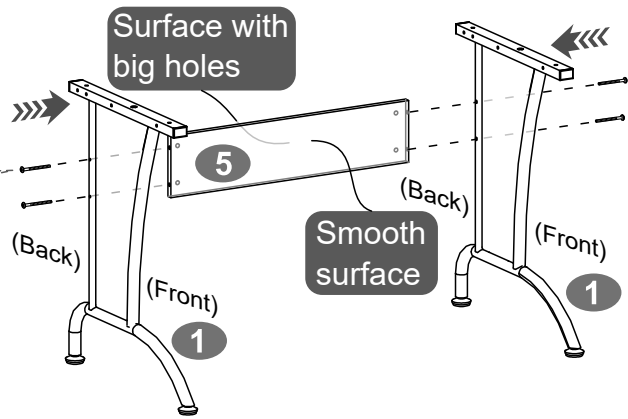
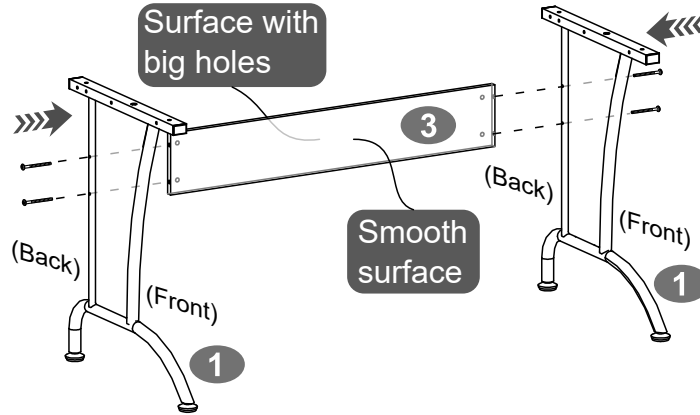

**STEP 4**

This step requires of 2 persons



**Hardware**

**D**  4 Pcs  
M6x55

**Tools (included)**



Use screws D to attach the long bar #4 to the legs #1 on the long frame, and the short bar #6 to the short frame.

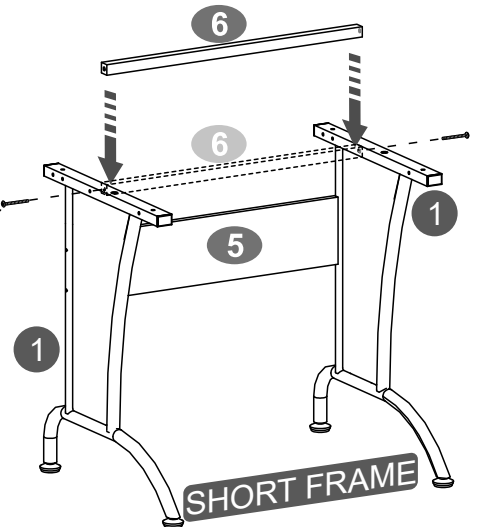
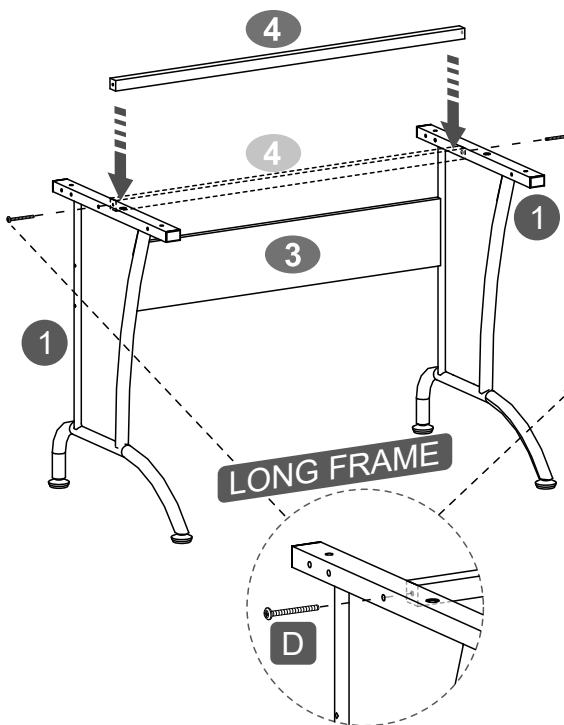

**STEP 5**

This step requires of 2 persons



You must now choose the configuration you want for the desk. Choose an option below, place the frames as instructed for your option, and go to the pages with the specific set of instructions.

**Option A:**

**STRAIGHT** with the long table on the **LEFT**.

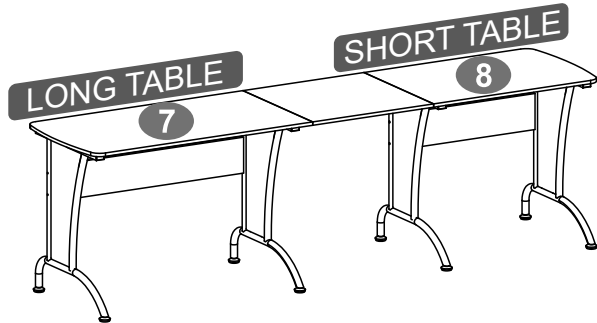

For this option, place the frames as shown below and follow the instructions A1 through A3 in pages 7 and 8.

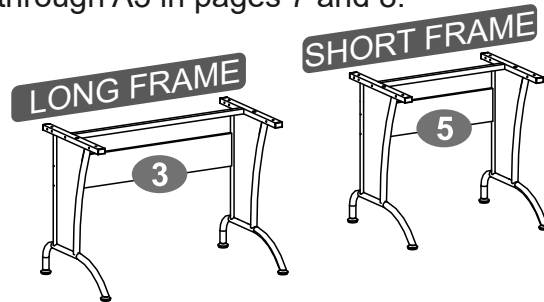

**Option B:**

**STRAIGHT** with the long table on the **RIGHT**.

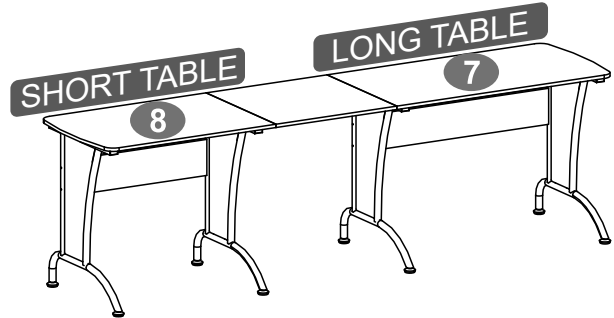

For this option, place the frames as shown below and follow the instructions B1 through B3 in pages 9 and 10.

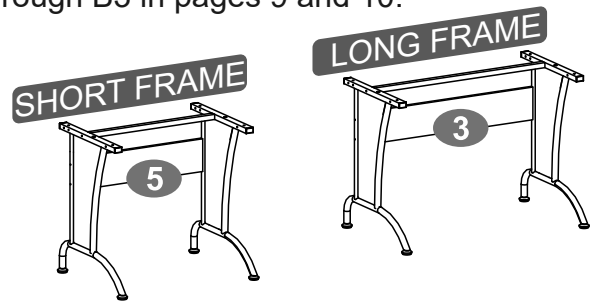

**Option C:**

**"L" shape** with the long table on the **LEFT**.

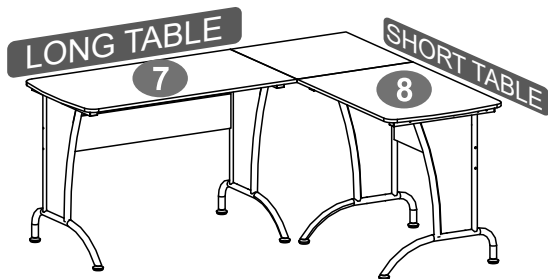

For this option, place the frames as shown below and follow the instructions C1 through C3 in pages 11 and 12.

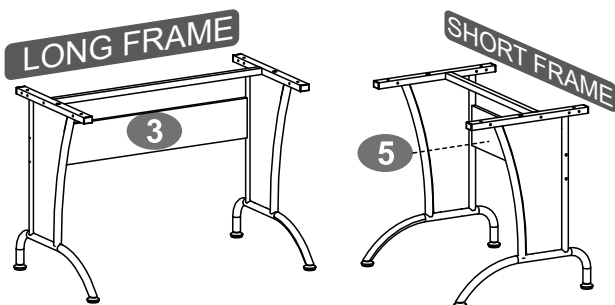

**Option D:**

**"L" shape** with the long table on the **RIGHT**.

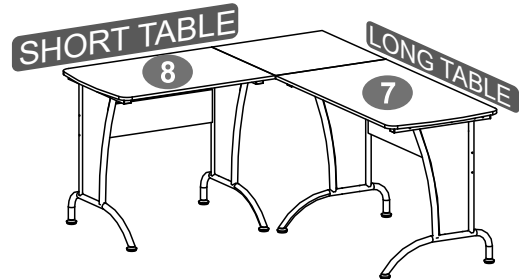

For this option, place the frames as shown below and follow the instructions D1 through D3 in pages 13 and 14.

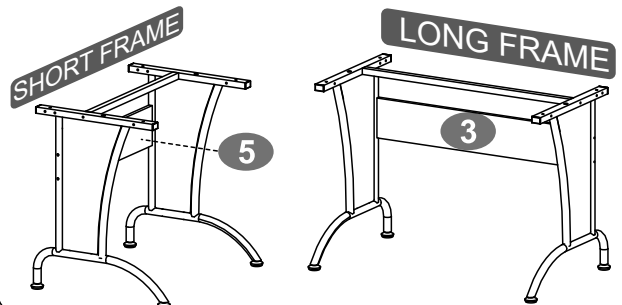

**STEP A1**

**Hardware**

<b>C</b>		4 Pcs
	M6x45	

<b>G</b>		4 Pcs
	M6	

**Tools (included)**

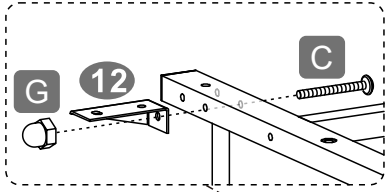
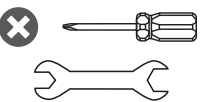

Attach the brackets #12 to the outside of the legs #1 with screws C and nuts G as shown.

The brackets attach:

- On the RIGHT leg of the LONG frame.
- On the LEFT leg of the SHORT frame.

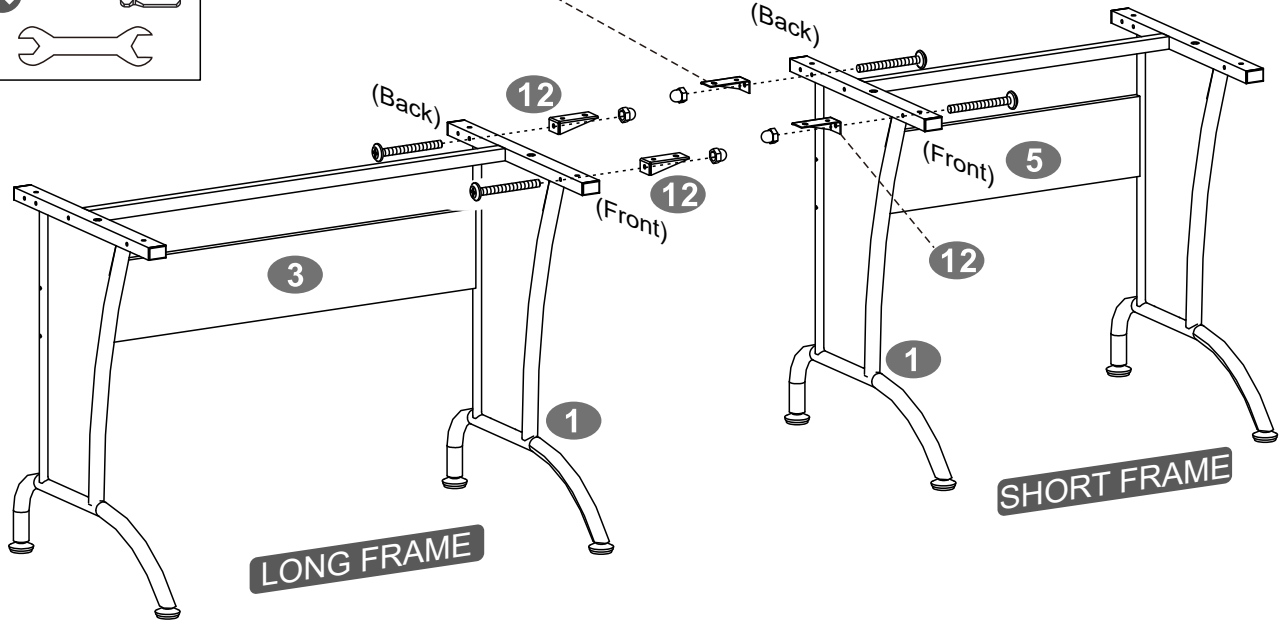

**STEP A2**

This step requires of  2 persons

**Hardware**

<b>B</b>		8 Pcs
	M6x35	

**Tools (included)**

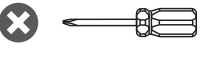

Assemble the tabletops #7 and #8 to the legs #1 of their respective frames with screws B (leave them loose).

**DO NOT TIGHTEN THE SCREWS UNTIL AFTER STEP A3!**

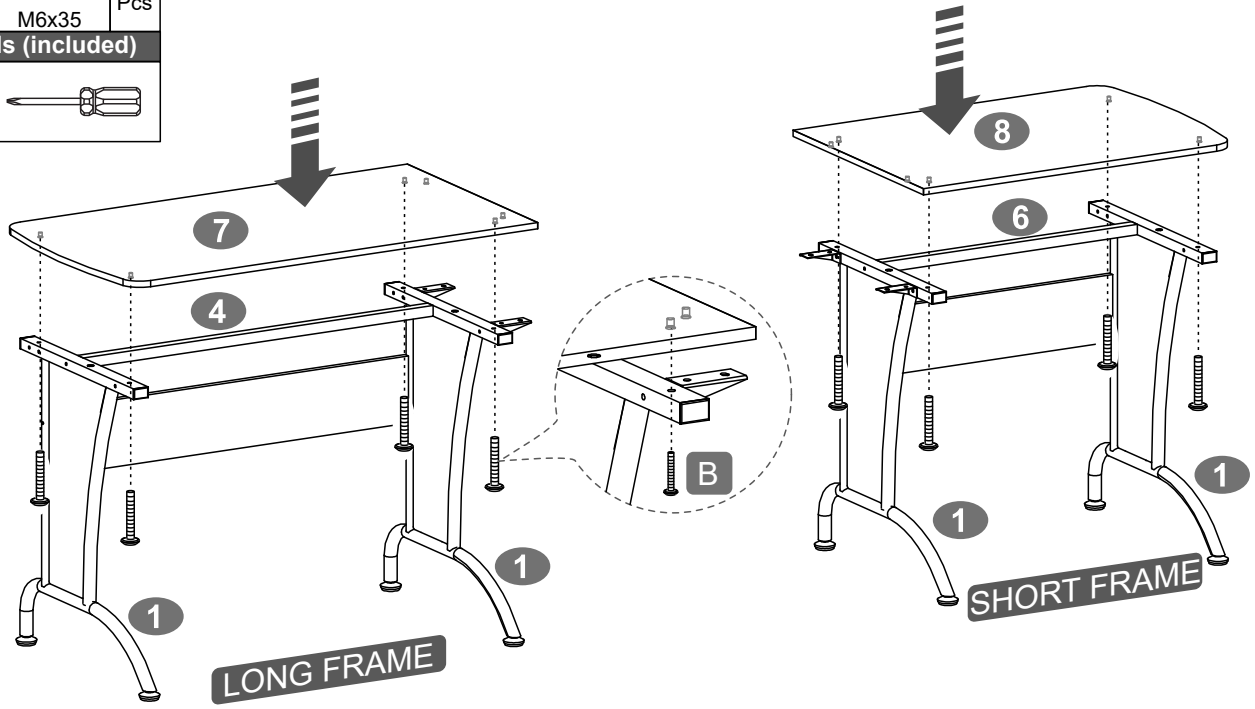



## STEP A3

This step  
requires of  
2 persons



## Hardware

A



M6x12

8  
Pcs

## Tools (included)

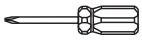

• FIRST assemble the middle tabletop #9 to the brackets #12 with screws A.

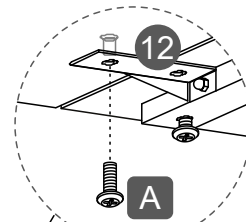

(View from underneath)

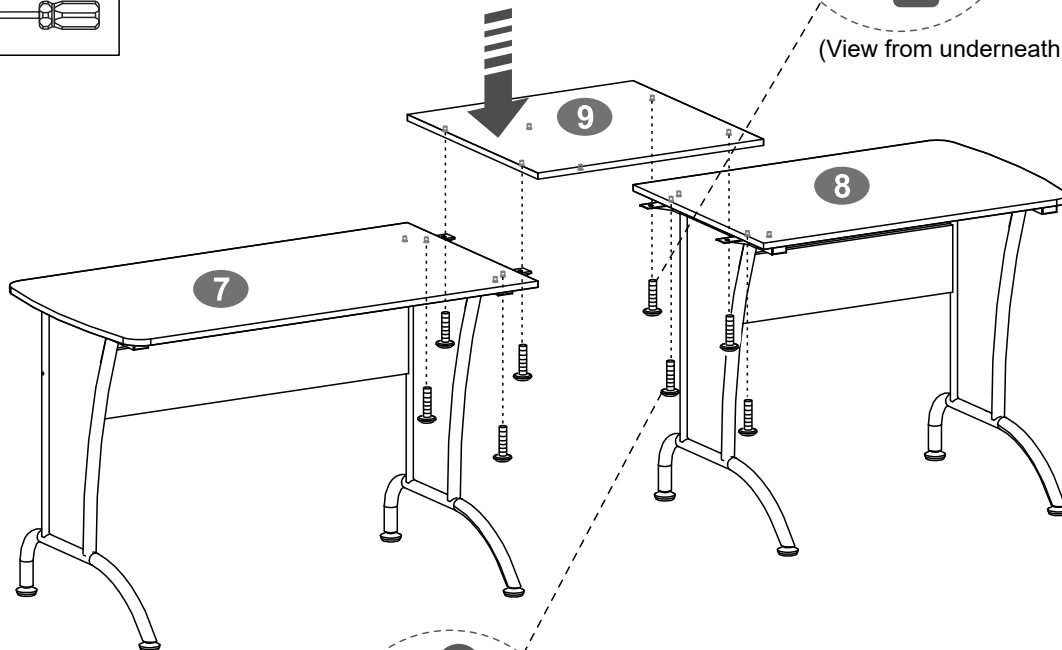

• THEN secure the tabletops #7 and #8 to the brackets #12 with screws A.

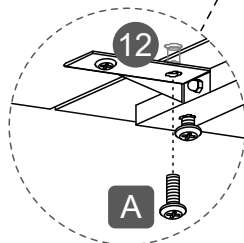

(View from underneath)

• LASTLY, proceed to tighten all the loose screws B from step A2.

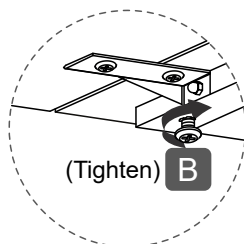

(View from underneath)

**ALL DONE!**

Please skip pages 9 through 14 and continue reading important information on pages 15 and 16.

**STEP B1**

**Hardware**

<b>C</b>		4 Pcs
	M6x45	

<b>G</b>		4 Pcs
	M6	

**Tools (included)**

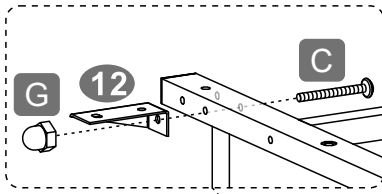
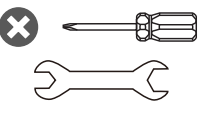

Attach the brackets #12 to the outside of the legs #1 with screws C and nuts G as shown.

The brackets attach:

- On the RIGHT leg of the SHORT frame.
- On the LEFT leg of the LONG frame.

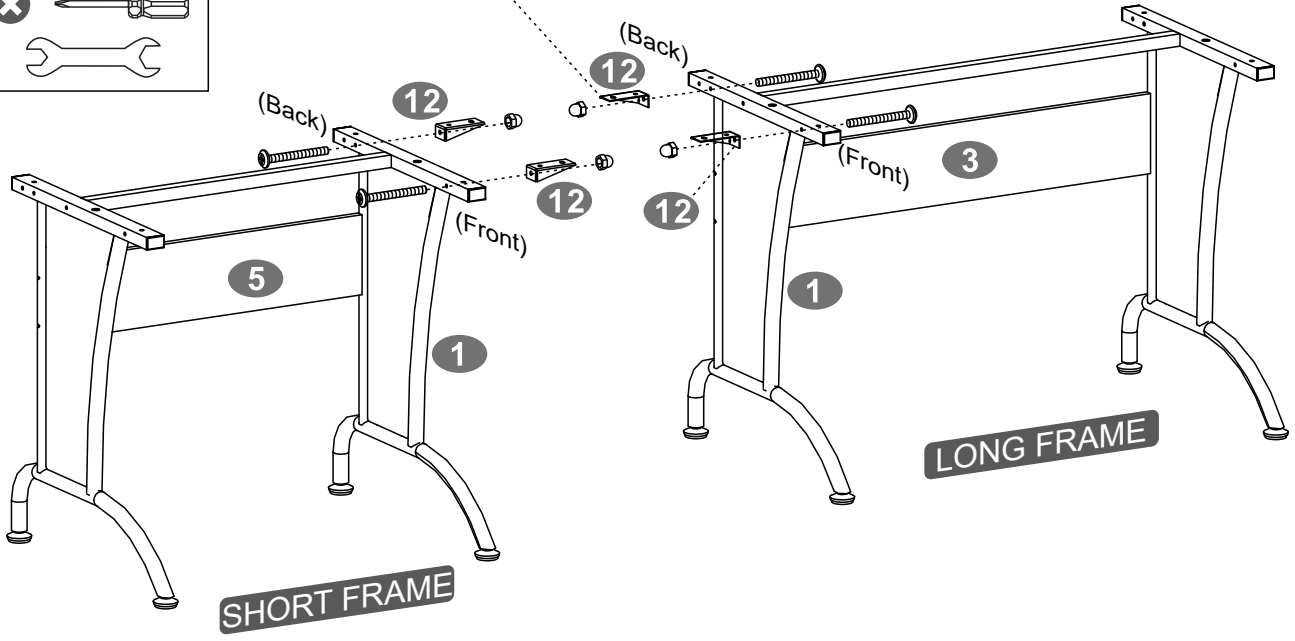

**STEP B2**

This step requires of  2 persons

**Hardware**

<b>B</b>		8 Pcs
	M6x35	

**Tools (included)**

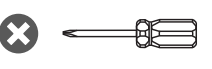

Assemble the tabletops #7 and #8 to the legs #1 of their respective frames with screws B (leave them loose).

**DO NOT TIGHTEN THE SCREWS UNTIL AFTER STEP B3!**

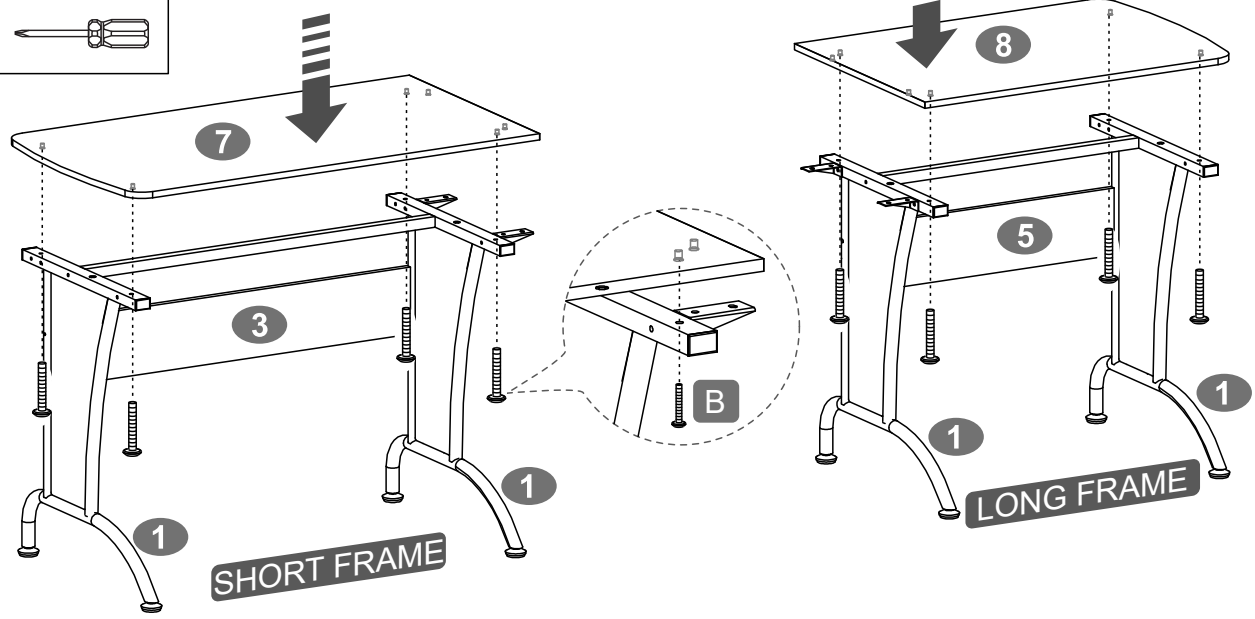

## STEP B3

This step  
requires of  
2 persons



## Hardware

A  8  
M6x12 Pcs

## Tools (included)



• FIRST assemble the middle tabletop #9 to the brackets #12 with screws A.

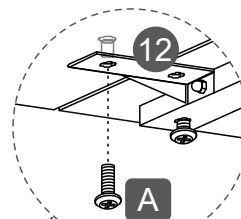

(View from underneath)

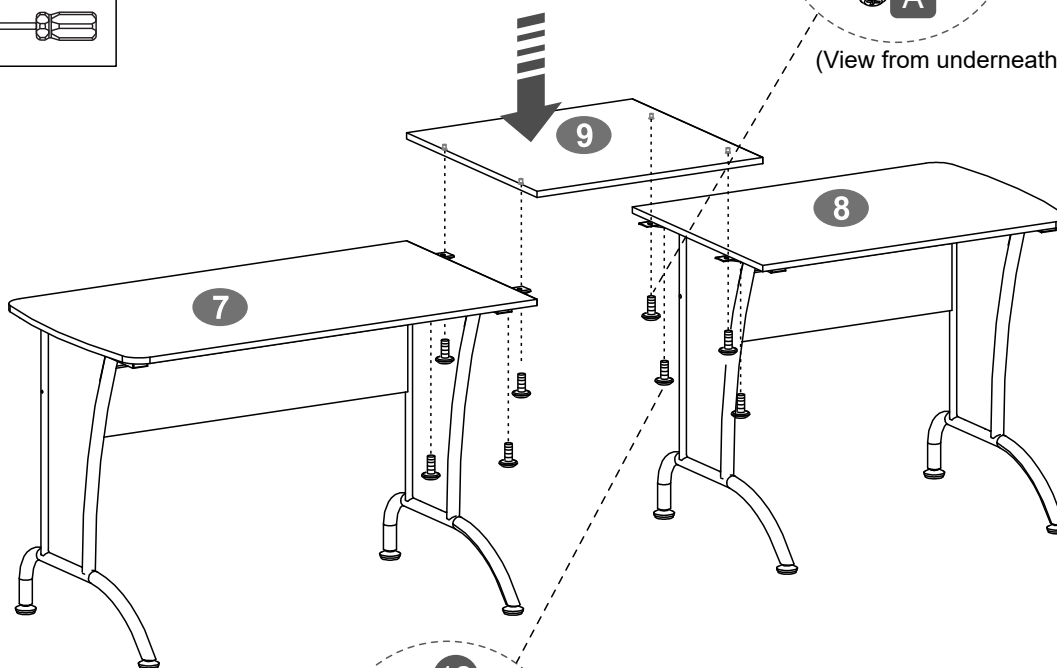

• THEN secure the tabletops #7 and #8 to the brackets #12 with screws A.

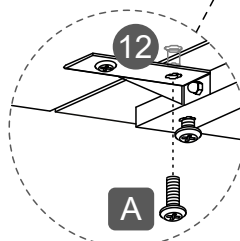

(View from underneath)

• LASTLY, proceed to tighten all loose screws B from step B2.

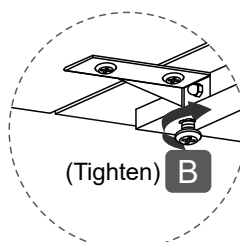

(View from underneath)

**ALL DONE!**

Please skip pages 11 through 14 and continue reading important information on pages 15 and 16.

**STEP C1**

**Hardware**

<b>C</b>		2 Pcs
	M6x45	

<b>G</b>		2 Pcs
	M6	

**Tools (included)**

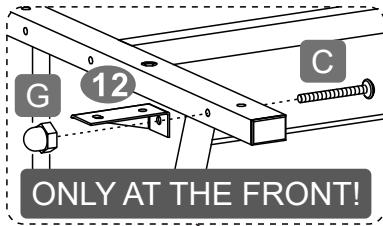
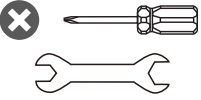

Attach **ONLY 2** of the brackets #12 to the outside of the legs #1 with screws C and nuts G, but **ONLY** at the **FRONT**.

The brackets attach:

- On the **RIGHT** leg of the **LONG** frame.
- On the **LEFT** leg of the **SHORT** frame.

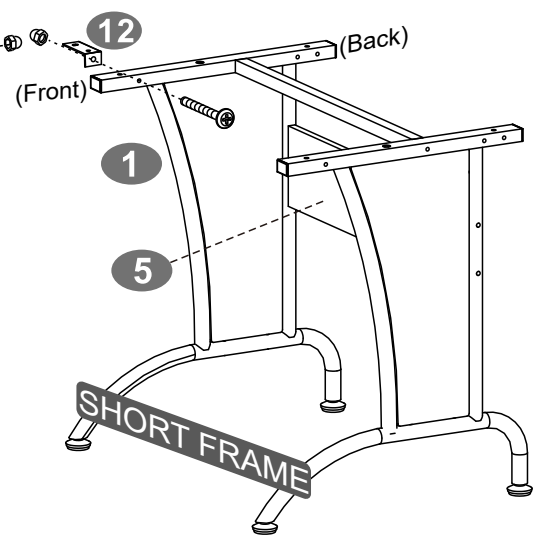
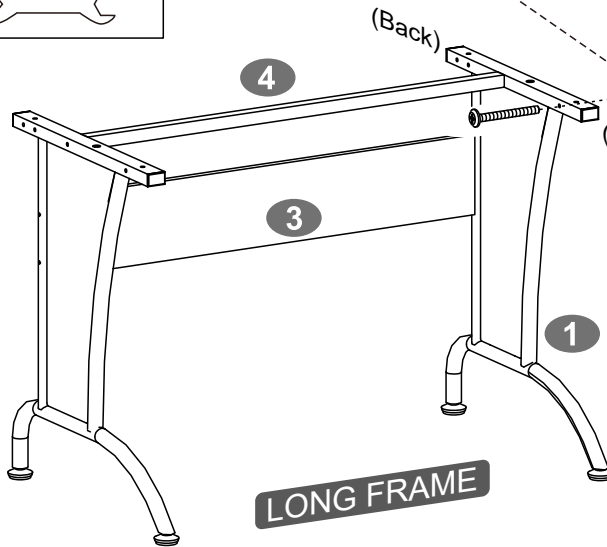

**STEP C2**

**Hardware**

<b>C</b>		4 Pcs
	M6x45	

<b>G</b>		2 Pcs
	M6	

**Tools (included)**

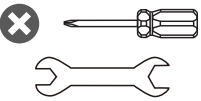

**DO NOT TIGHTEN THE SCREWS UNTIL AFTER STEP C3!**

- **FIRST** assemble the corner support #10 to the legs #1 at the back of the frames with screws C from **INSIDE** the leg (leave them loose).
- **THEN** secure the corner frame #10 to the legs #1 with screws C from **OUTSIDE** the leg and nuts G from **INSIDE** (leave them loose).

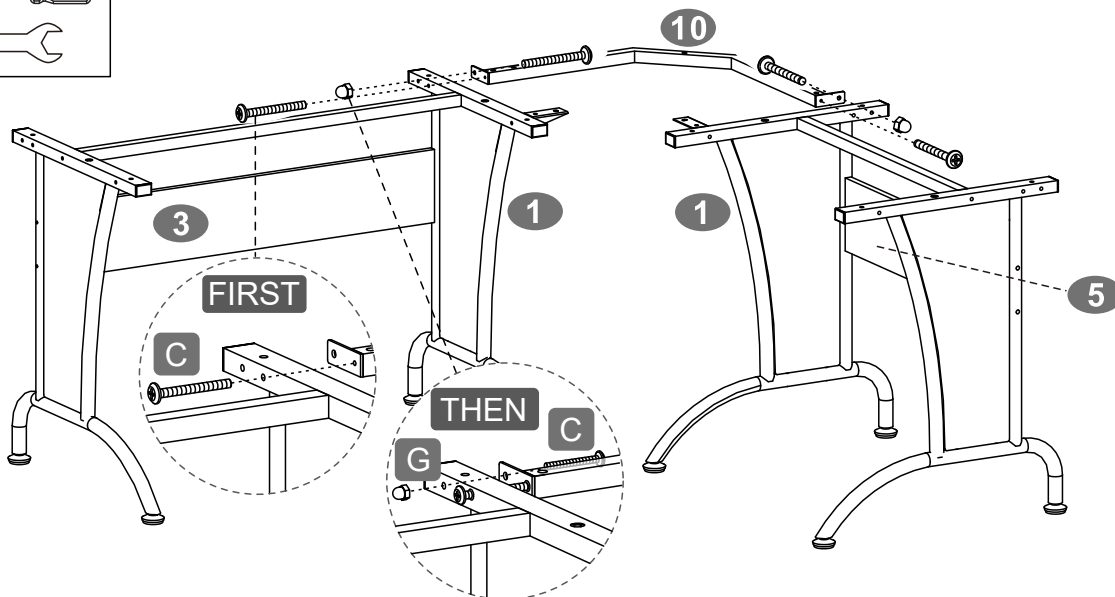

**STEP C3**

This step requires of 2 persons



**Hardware**

A		4 Pcs
B		13 Pcs

**Tools (included)**

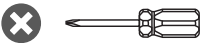

**FIRST:** Use qty. 10 screws B to assemble the tabletops #7 and #8 to the legs #1 of their respective frames and to the support #10.

**DO NOT TIGHTEN THE SCREWS YET!**

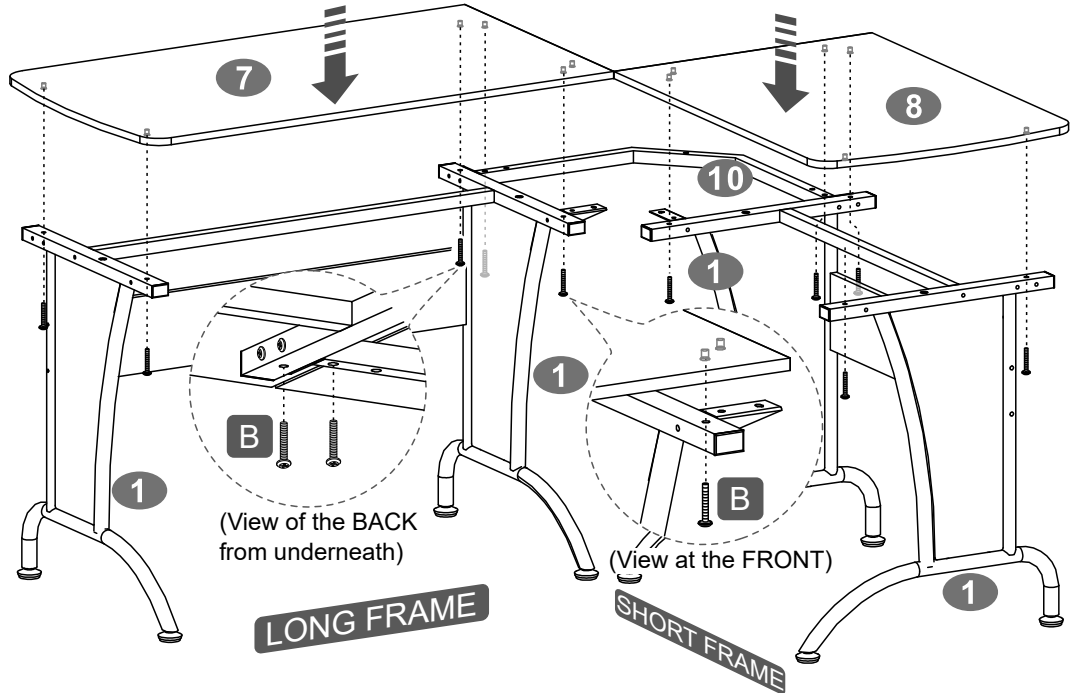

**THEN:** Use screws B to assemble the middle tabletop #9 to the support #10, but **DO NOT TIGHTEN THE SCREWS.**

**LASTLY:** Use screws A to secure all 3 tabletops to the brackets #12, and proceed to tighten all the loose screws.

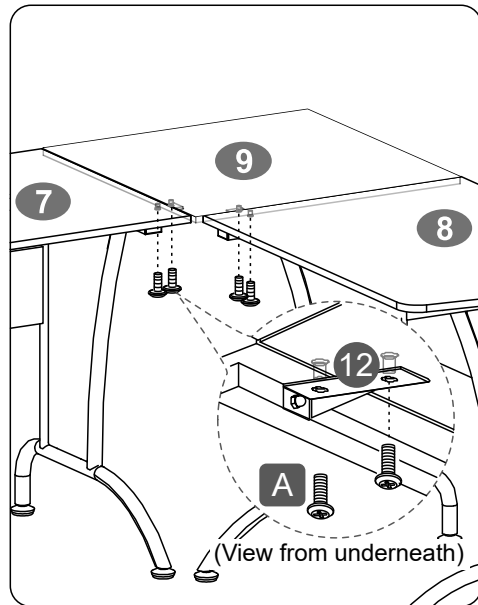
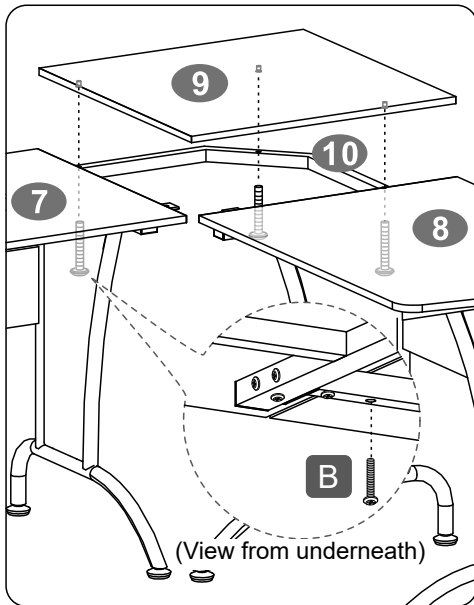

**ALL DONE!**

**Please skip pages 13 and 14, and continue reading important information on pages 15 and 16.**

**STEP D1**

**Hardware**

<b>C</b>	 M6x45	2 Pcs
----------	--	----------

<b>G</b>	 M6	2 Pcs
----------	---	----------

**Tools (included)**

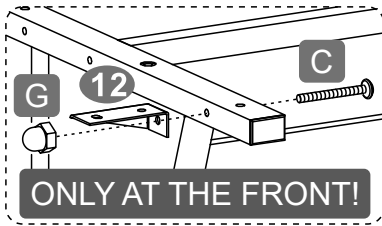
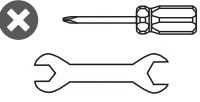

Use screws C and nuts G to attach ONLY qty 2 of the brackets #12 to the outside of the legs #1 and ONLY at the FRONT.

The brackets attach:

- On the RIGHT leg of the SHORT frame.
- On the LEFT leg of the LONG frame.

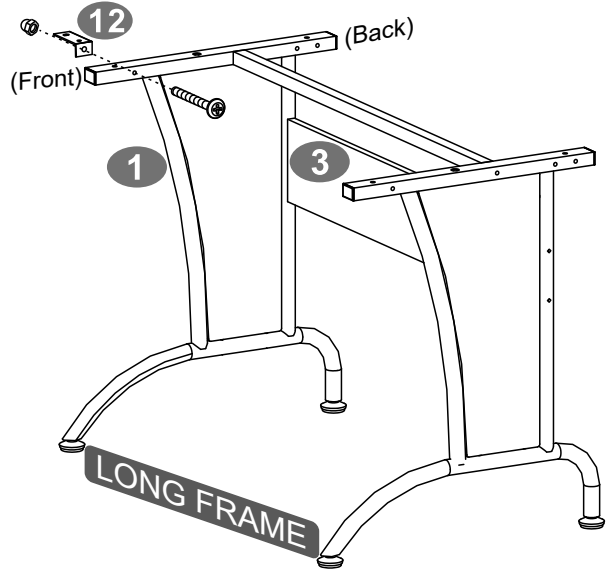
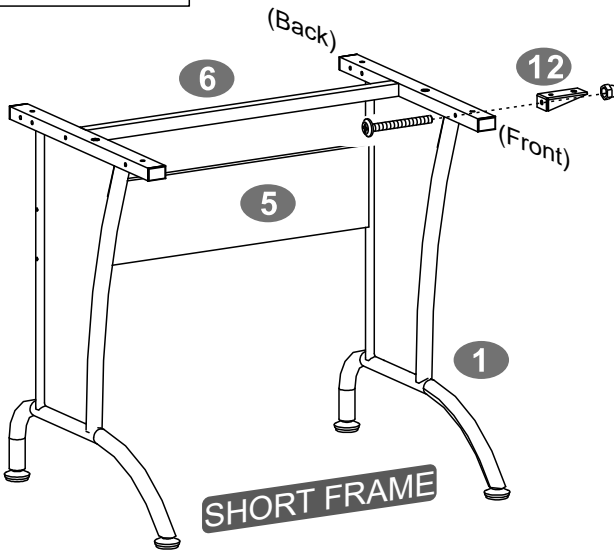

**STEP D2**

**Hardware**

<b>C</b>	 M6x45	4 Pcs
----------	--	----------

<b>G</b>	 M6	2 Pcs
----------	---	----------

**Tools (included)**

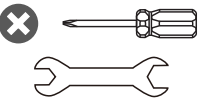

**DO NOT TIGHTEN THE SCREWS UNTIL AFTER STEP C3!**

- FIRST assemble the corner support #10 to the legs #1 at the back of the frames with screws C from INSIDE the leg (leave them loose).
- THEN secure the support #10 to the legs #1 with screws C from OUTSIDE the leg and nuts G from INSIDE (leave them loose).

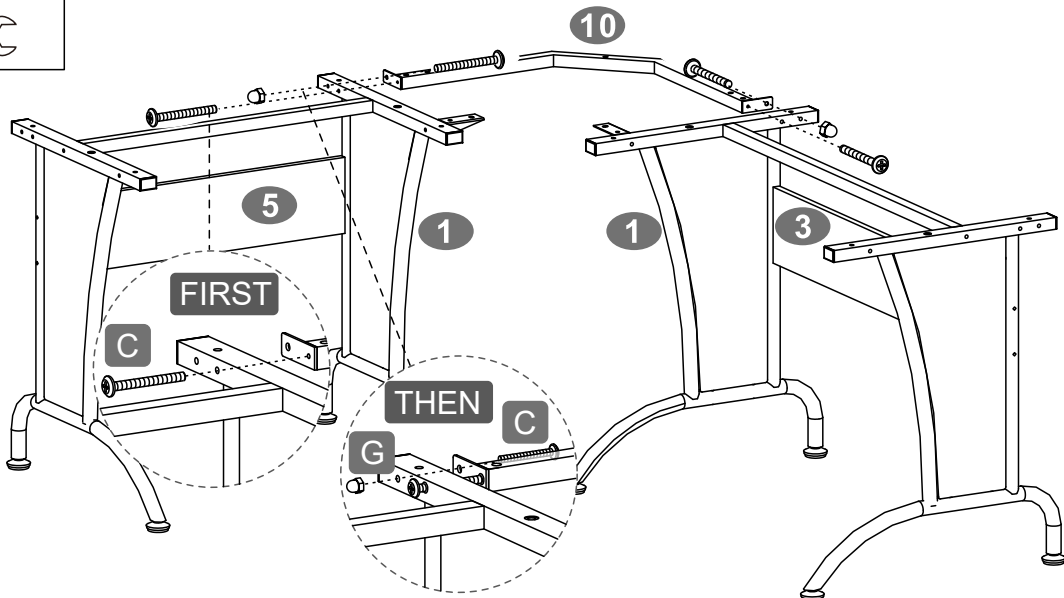

**STEP D3**

This step requires of 2 persons



**Hardware**

A		4 Pcs
B		13 Pcs

**Tools (included)**



**FIRST:** Use qty. 10 screws B to assemble the tabletops #7 and #8 to the legs #1 of their respective frames and to the support #10.

**DO NOT TIGHTEN THE SCREWS YET!**

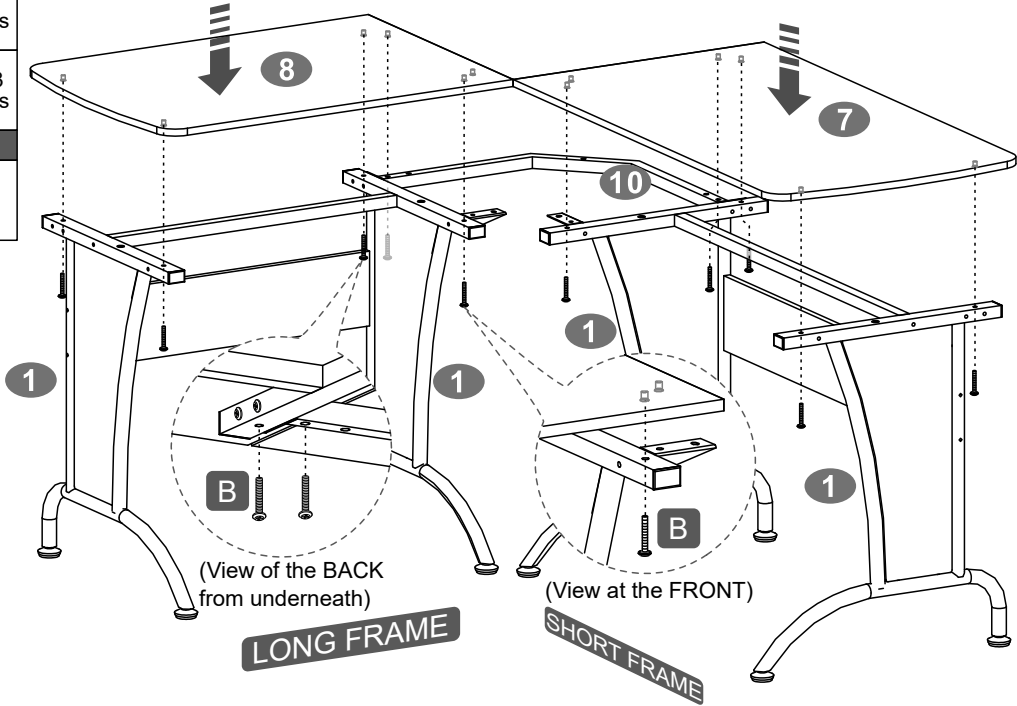

**THEN:** Use screws B to assemble the middle tabletop #9 to the support #10, but **DO NOT TIGHTEN THE SCREWS.**

**LASTLY:** Use screws A to secure all 3 tabletops to the brackets #12, and proceed to tighten all the loose screws.

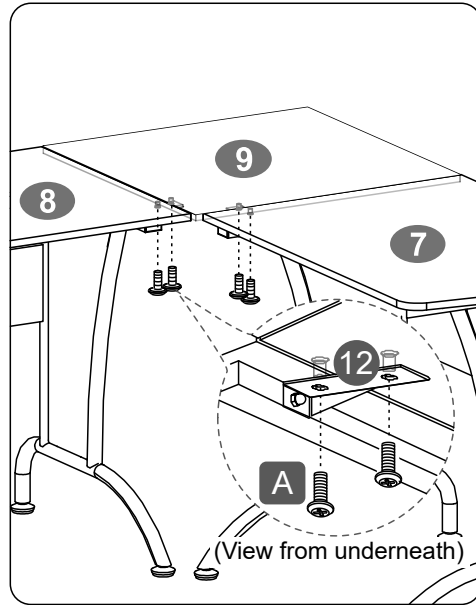
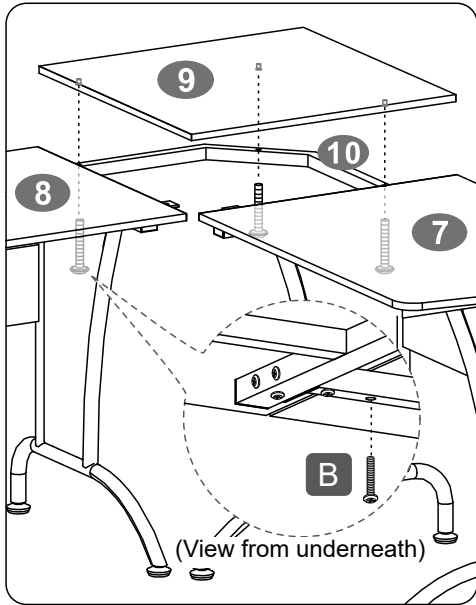

**ALL DONE!**

**Please continue reading important information on the next pages.**

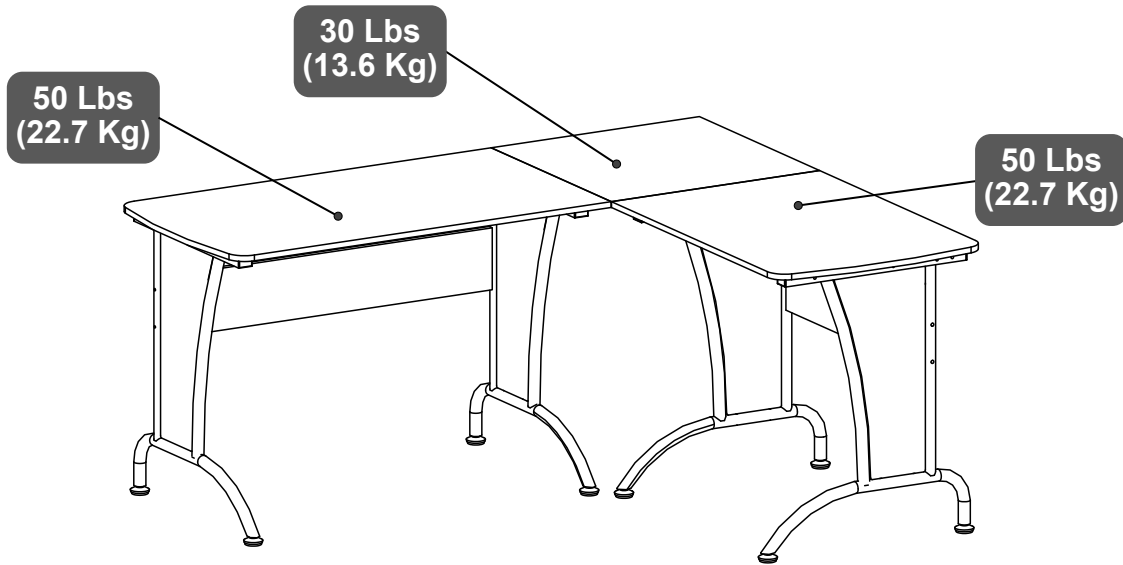
**WEIGHT LIMITS****WARNINGS**

- Do not exceed the indicated weight limits.
- Do not expose the surfaces to direct sunlight or to extreme environmental conditions.
- Do not use solvents or abrasive materials to clean the unit.
- Do not sit on the unit.
- Do not allow small children to play under or over the unit.
- Do not pull, push or drag the unit to move it for more than 1 feet. The unit must be lifted by at least 2 persons when moving in the same or adjacent rooms.
- Before moving the unit, make sure to secure or remove any object that is heavy or might fall off.
- When lifting the unit, use both hands and bend your knees, not your backs.
- Do not use the product if screws are loose or missing, or if you notice damaged parts.
- The warranty does not extend to regular wear and tear, nor the manufacturer assumes liability for damages or consequences due to accidents, incorrect assembly, negligence, improper use, modifications, or not heeding the above warnings.

**CARE AND MAINTENANCE**

- Clean the surfaces preferable with a clean cloth damped in a solution of mild soap and water, then dry with a clean towel.
- If you decide to use a cleaning agent, test first on an area hidden from view such as underneath the tabletop.
- Every 4 months, inspect the unit completely and make sure that all screws are tighten.
- When transporting the unit to places far away, protect and secure the unit to avoid damage in transit.



**TECHNI MOBILI WARRANTY****DESKS: LIMITED 5-YEAR WARRANTY**

RTA Products, LLC warrants to the Original Purchaser who acquired a new product from RTA Products or its authorized resellers that this product will be free from defects in its workmanship and materials, under normal use and service conditions, as described herein. "Defects" as used in this warranty, is defined as any imperfections that impair the use of the furniture or product. RTA Products LLC will replace any defective part, at its discretion, and without charge to the original purchaser other than the freight from the end consumer to RTA Products.

Replacement parts can only be supplied if parts are available. Items out of production may be unavailable. This warranty will be effective for the applicable time period beginning the date of purchase on your original sales receipt. RTA product's obligation under this warranty is limited to repairing or replacing products or parts as provided herein. This product has been designed for and is intended for office and home-office use only. This warranty is Original Purchaser's sole remedy for product defects, and this warranty does not extend to any product, or damage to any product, caused by or attributed to abuse or misuse, products used for commercial or rental purposes, use modifications of, or attachments to the product, and products or parts not used, maintained, or extended hereunder is in lieu of any and all other warranties, express or implied, including without limitations any implied warranty or merchantability or of fitness for a particular purpose. Please note, all desks made with PVC Laminate surface should not be exposed to direct sunlight, as it may damage the material. Damage of this nature is not covered under this warranty.

RTA Products will not be responsible for indirect, special, incidental or consequential damages. This warranty is limited to merchandise purchased in the Continental United States, excludes AK, HI and PR. Some States do not allow the exclusion or limitation of incidental or consequential damages, so the above limitations or exclusions may not apply to you. This warranty gives you specific legal rights. You may also have other rights that may vary from state to state.

**To file a Claim within the 48 contiguous United States:**

Email us to [warranty@rtaproducts.com](mailto:warranty@rtaproducts.com) to explain the defect and provide your name, address, phone number, model number of our product, date and place, and proof of purchase. Please provide pictures of the damage or defect. If we determine that a replacement will remedy the situation, and in order to determine the extent or the cause of the defect, purchaser may be requested to send the part in question at purchaser's expense. Once we receive the part, we will examine it and determine whether the claim is valid (or not), and then proceed to send the replacement. We will ship the replacement at our expense.

**Replacement Parts for International Customers & AK-HI-PR orders:**

RTA Products will replace the part free of charge, while **the customer is responsible for shipping costs plus any International local taxes or duties.**