

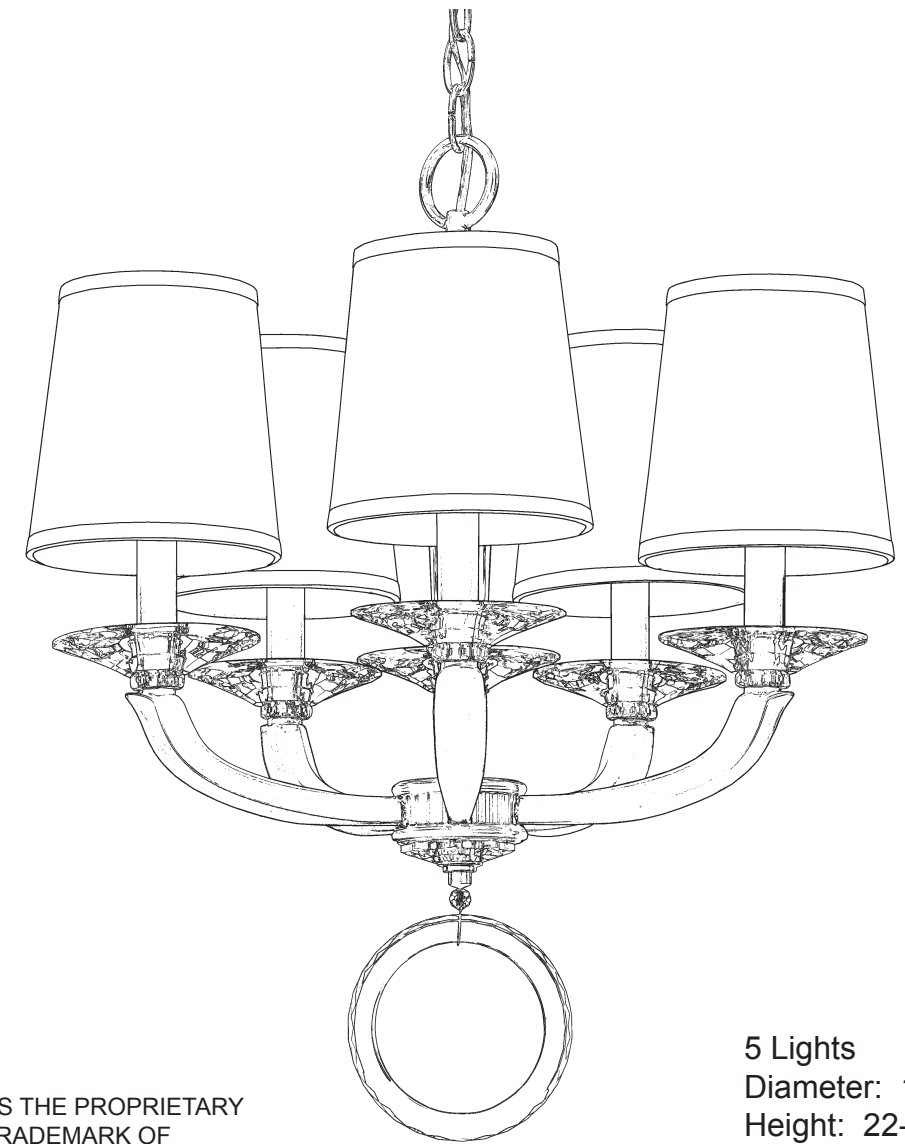

SCHONBEK®

EMILEA MA1005N- __ __ O



THIS DESIGN IS THE PROPRIETARY TRADE DRESS/TRADEMARK OF SWAROVSKI LIGHTING, LTD.

5 Lights
Diameter: 19-1/2"
Height: 22-1/2"
Hanging Weight: 14lbs.



SCHONBEK®

MAX <u>40</u> W	110-120 V							

SCHONBEK® is a member of the Swarovski group.

WARNING:

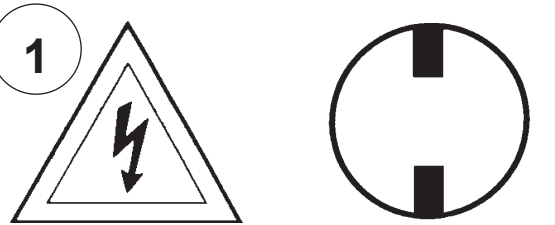
1 

Electrical Danger Turn Power Off

All electrical components must be installed by a licensed electrician in accordance with the National Electric Code and the appropriate local electrical codes.

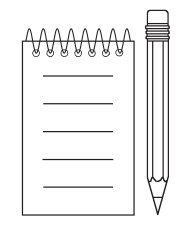
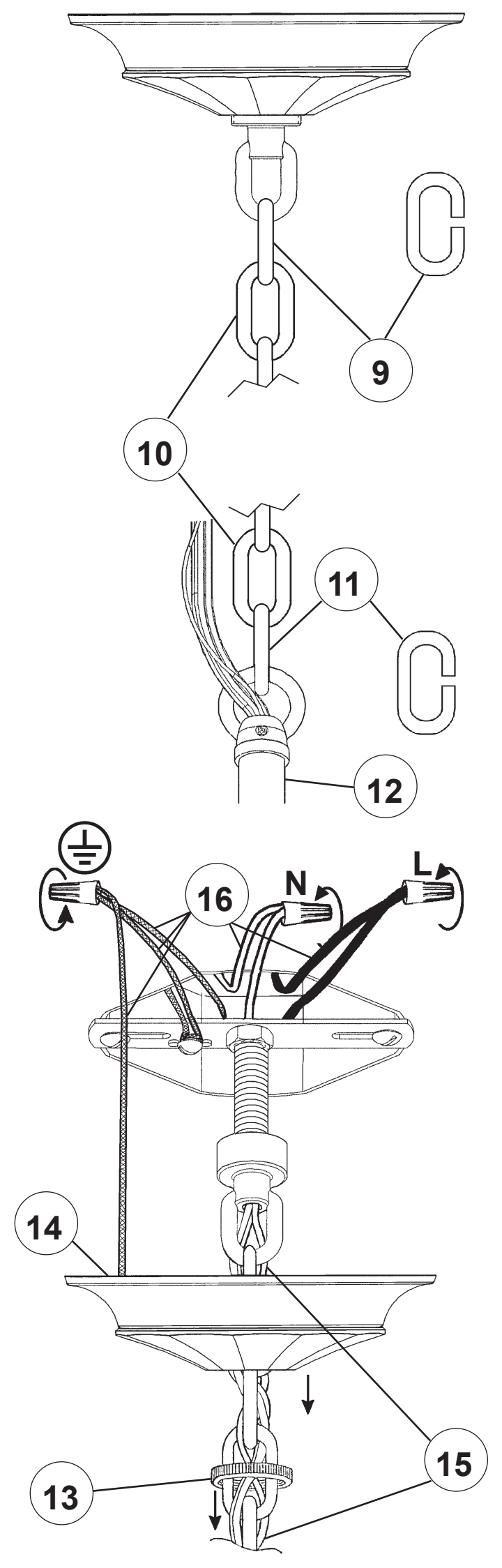
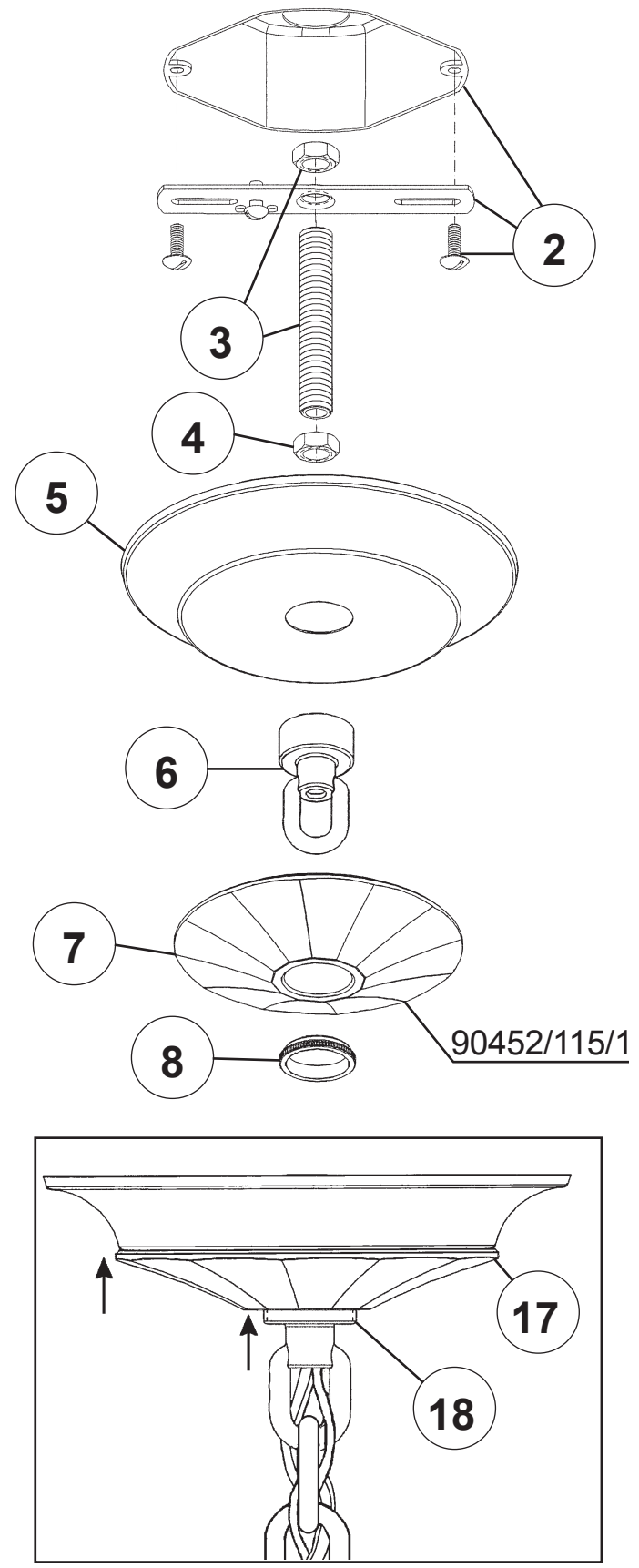

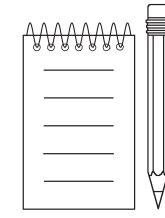
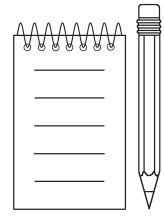

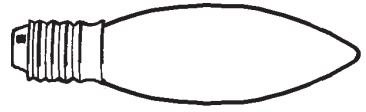

You will need 5 - B10
25 Watts Recommended
40 Watts Max

**Install bulbs and be sure
to test fixture BEFORE
trimming.**

