

## **NOTICE**

- \* Please make sure that you have all parts indicated and they are in good condition before you begin assembly of this item. Refer to part list and hardware list below for guidance.
- \* This item should be assembled on a soft surface to prevent scratching the finish during assembly.
- \* This item may require periodic tightening.
- \* If you are having difficulty, our friendly Customer Care team is always here to help. Please email [customersupport@safavieh.com](mailto:customersupport@safavieh.com)

## **PREPARATION**

- \* Before beginning assembly of product, make sure all parts are present. Compare parts with part contents list and hardware contents list.
- \* If any part is missing or damaged, do not attempt to assemble the product.
- \* Estimated Assembly Time: 10 minutes.

## **CARE AND MAINTENANCE**

Always use felt pads under all articles to prevent discoloration or softening of the lacquer. Plastic and rubber bases on items can discolor wood. Wipe up spills immediately and avoid common hazards such as hot dishes, harsh solvents, and abrasives. Cleaning should be done with a soft lint free cotton cloth dampened with water.

### **Part List and Hardware List**

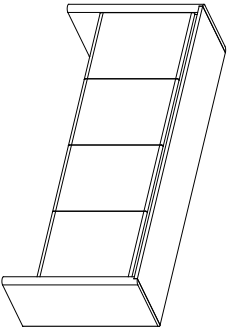
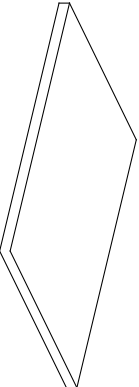
<b>PIECE</b>	<b>DESCRIPTION</b>	<b>PICTURE</b>	<b>QUANTITY</b>
<b>A</b>	Top Table		1X
<b>B</b>	Shelf		4X

# SAFAVIEH CO U T U R E

**Model #: SFV7229A**

**Product Dimensions: 75.0"D x 18.0"W x 31.0"H**

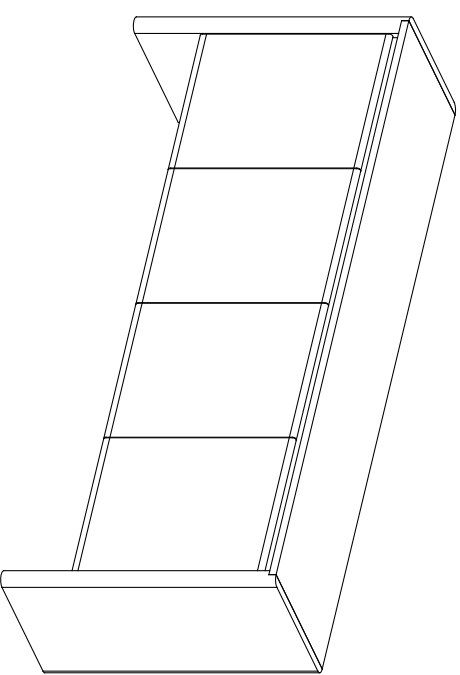

### **▲ WARNING ▲**

Weight capacity - 200LBS  
Warning: Do not stand on Table  
Warning: Do not over torque bolts

# PREPARATION

- \* Before beginning assembly of product, make sure all parts are present. Compare parts with part contents list and hardware contents list.
- \* If any part is missing or damaged, do not attempt to assemble the product.
- \* Estimated Assembly Time: 10 minutes.
- \* If you are having difficulty, our friendly Customer Care team is always here to help. Please email [customersupport@safavieh.com](mailto:customersupport@safavieh.com)

(OPEN THE DOORS)

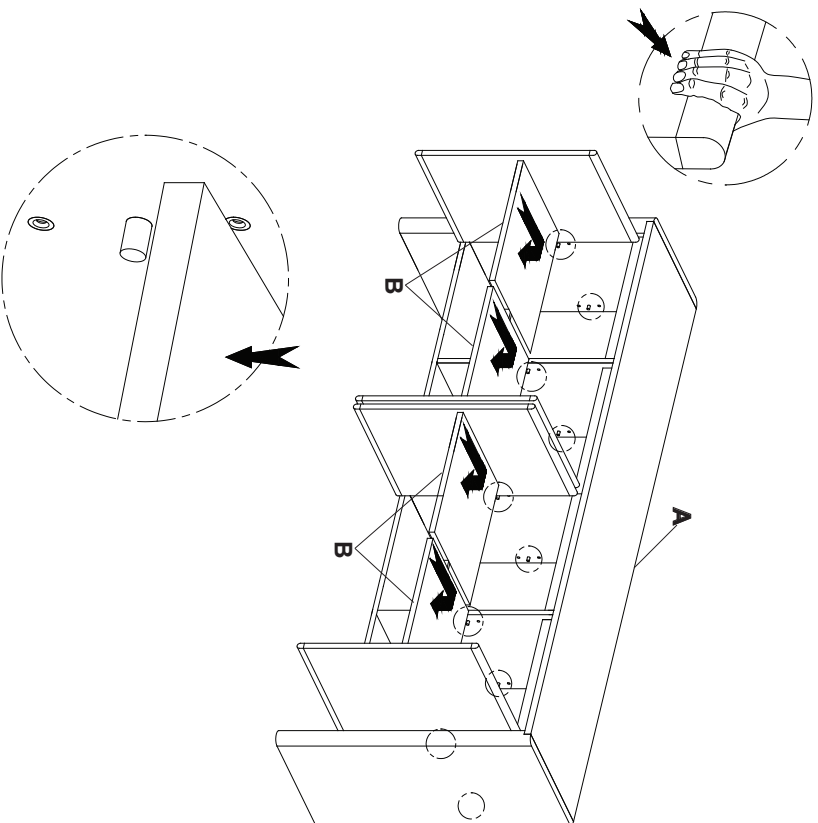

**STEP1:** Push to open door. Next, insert the Shelves (B), making sure each shelf rests evenly on the Shelf Pin as shown.

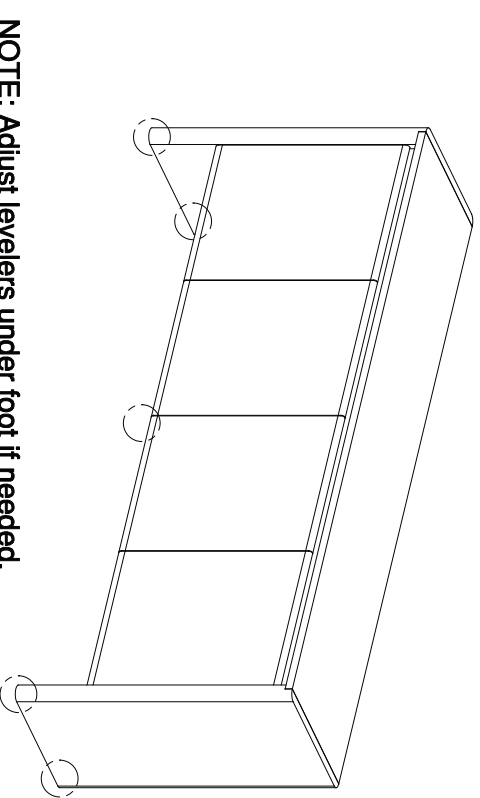

**NOTE:** Adjust levelers under foot if needed.

**STEP2:** Assembly is now complete and the Product is ready for use.