

## Coconino Wicker Chat Set

Item#: 62966

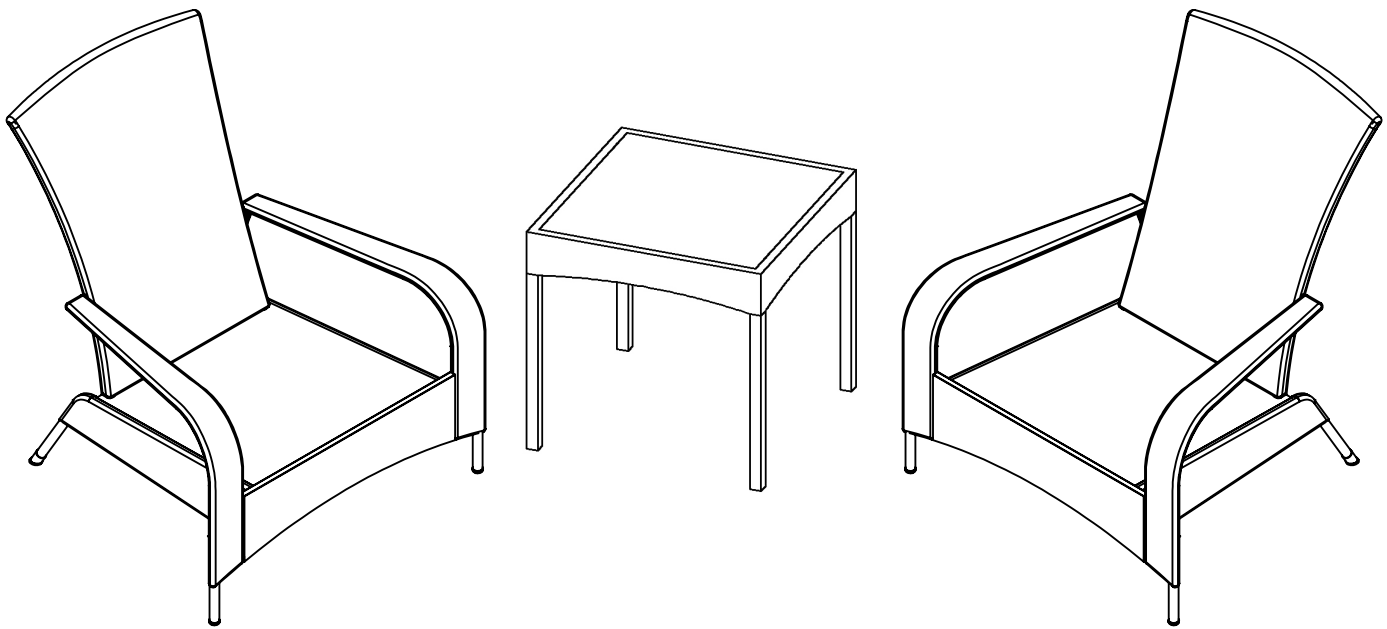

**SAVE THESE  
INSTRUCTIONS FOR  
FUTURE REFERENCE.**



**ATTACH YOUR  
RECEIPT HERE.**

Keep a copy of your proof of purchase or order confirmation which will be needed if you need to contact us about warranty coverage.

Purchase Date: \_\_\_\_\_



### **Questions, problems, missing parts?**

Before returning to your retailer, our exceptional customer service is available.

Call us toll-free at **(866) 985-7877**, email us at **[cservice@welltraveled.net](mailto:cservice@welltraveled.net)**, or go online and live chat at **[www.wtliving.com](http://www.wtliving.com)**. Our hours are: **9 a.m. – 6 p.m., EST, Monday – Friday**



## BEFORE YOU BEGIN

Before beginning assembly, make sure all parts are present. Compare parts received with the “Parts List.” If any part is missing or damaged, do NOT attempt to assemble the product. Please read and understand this entire manual before attempting to assemble, operate or install this product. If you have any questions regarding the product, please call us toll-free at **(866) 985-7877**, email us at [cservice@welltraveled.net](mailto:cservice@welltraveled.net), or go online and live chat at [www.wtliving.com](http://www.wtliving.com). Our hours are: **9 a.m. – 6 p.m., EST, Monday – Friday**



## GENERAL INFORMATION

Your new furniture is made from the finest materials available. It should provide many years of enjoyment with minimal care.

Keep your furniture clean. For best results, clean the chair with a soft, damp cloth. If you use furniture covers, always make sure the chair is clean and completely dry before covering as mold may form in dark, wet places. Remove cushions prior to covering and store them in a dry, temperature controlled place. Check the hardware on your furniture regularly to make sure it is secure.

The weight limit for each chair is 220 lbs.



## SAFETY INFORMATION

### WARNING

DO NOT stand or allow children to stand on the assembled furniture.

DO NOT tighten hardware completely until instructed to do so. After final alignment, make sure all hardware is securely fastened. NEVER use a power tool to assemble or tighten your furniture. Perform periodic checks to make sure the hardware is secure and tighten if needed.

### CAUTION

READ all instructions before beginning assembly. Failure to do so may result in faulty assembly and potential injury. Assemble the items on a soft, non-abrasive surface such as a carpet or cardboard to avoid damaging the items.

**CHAIRS**

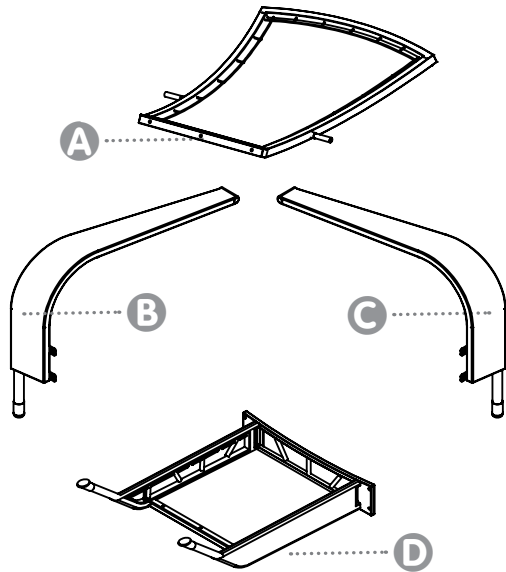

PART	DESCRIPTION	QUANTITY (per chair)
A	Seat Back	1
B C	Arms	2
D	Seat	1



**HARDWARE CONTENTS**

(per chair)

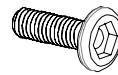

**E**  
M6x20 Bolts  
Qty: 6

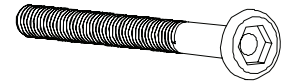

**F**  
M6x40 Bolts  
Qty: 3



**G**  
M6 Washers  
Qty: 9



Hex Wrench  
Qty: 1

**TABLE**

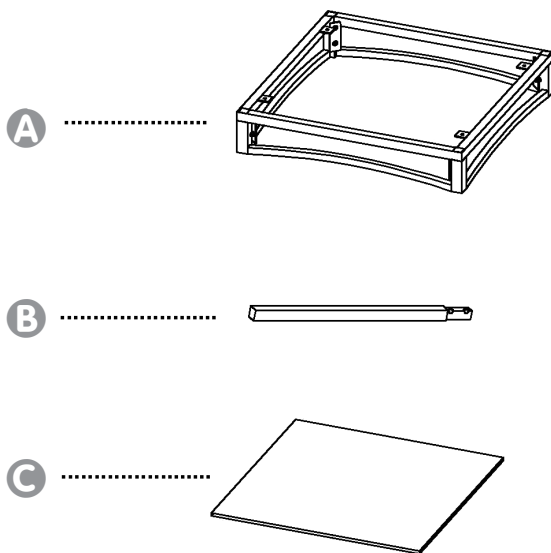

PART	DESCRIPTION	QUANTITY
A	Table Top	1
B	Leg	4
C	Glass Top	1



**HARDWARE CONTENTS**

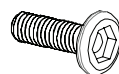

**D**  
M6x20 Bolts  
Qty: 8



**E**  
M6 Washers  
Qty: 8

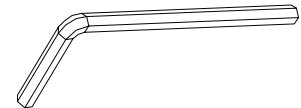

Hex Wrench  
Qty: 1

# CHAIR ASSEMBLY



Before you begin, place all parts on a nonabrasive, level surface. We recommend that you unpack and assemble one piece of furniture at a time to avoid hardware mix-ups.

- 1** Attach the **arms B** and **C** to the front of the **Seat D** with 4 **Bolts E** and **Washers G** as shown. Tighten using the **Hex Wrench**.

**Hardware Used:** **E** Bolts (6x20mm) x 4  
**G** Washers (6mm) x 4

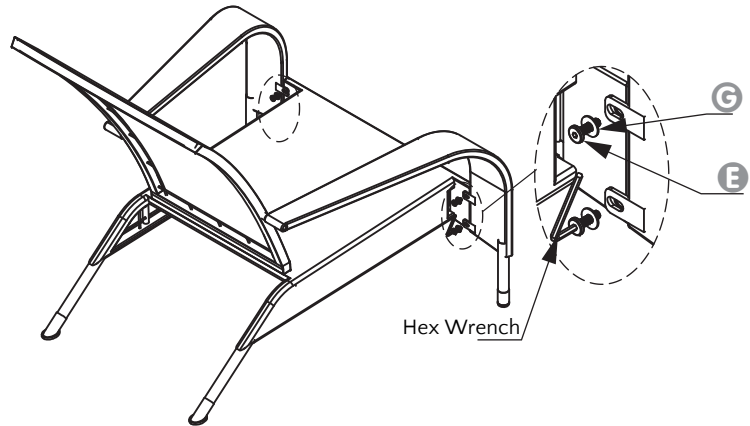

- 2** Attach the **arms B** and **C** to the **Seat Back A** by sliding the arms onto the pegs on the sides of the **Seat Back**, then using a **Bolt E** with a **Washer G** to fasten each **Arm** as shown. Tighten using the **Hex Wrench**.

**Hardware Used:** **E** Bolts (6x20mm) x 2  
**G** Washers (6mm) x 2

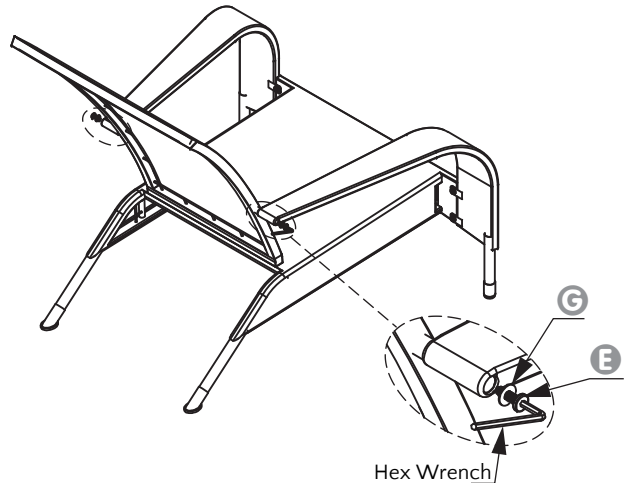

- 3** Attach the **Seat D** to the **Seat Back A** using 3 **Bolts F** with **Washers G**, inserted through the **Seat** and into the **Seat Back**. Tighten using the **Hex Wrench**.

**Hardware Used:** **F** Bolts (6x40mm) x 3  
**G** Washers (6mm) x 3

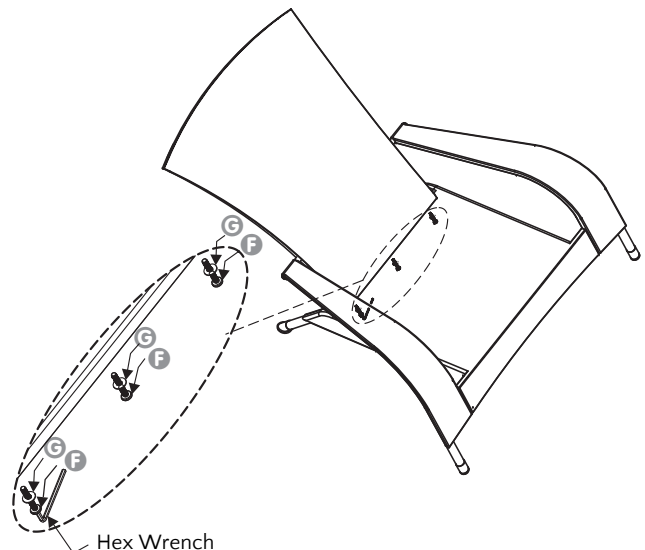

**Check all hardware. Your chair is now ready for use!**

**Use these instructions to build the second chair in the same manner.**



**1** Turn the **Table Top A** upside-down and place on a protected surface.

Locate the 2 eyelets drilled at one corner of the top of each **Leg B**. Insert the **Legs B** into the holes at each corner of the **Table Top**, with the eyelets facing toward the middle of the **Table Top**.

Attach the **Legs** to the **Table Top** using 2 **Bolts D** with **Washers E** per **Leg**. Tighten using **Hex Wrench**.

**Hardware Used:**

- D** Bolts (6x20mm) x 8
- E** Washers (6mm) x 8

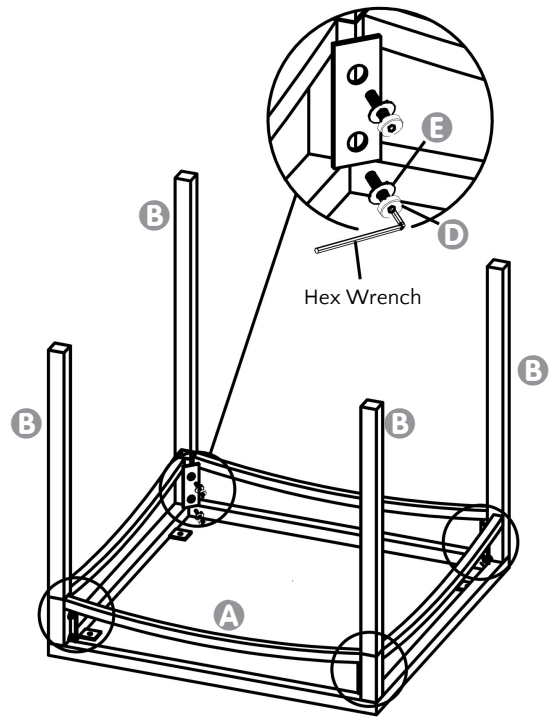

**2** Turn the assembled table base back upright. Check all hardware connections.

Gently place the **Glass Top C** on the table base.

**Your table is now ready for use!**

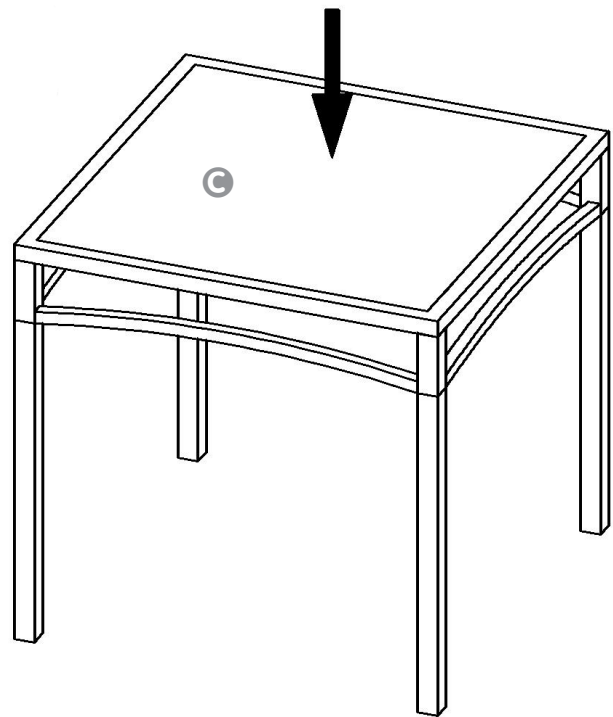



## 1 YEAR LIMITED WARRANTY

### Customers in the contiguous US

All components are warranted for a period of 1 year after date of purchase by the original owner against defects in materials and workmanship under normal use. This warranty does NOT cover normal wear and weathering, assembly and/or maintenance OR use in a commercial application if model is not designated as a commercial model. At Well Traveled Living's sole discretion, products under warranty will be repaired and/or replaced at no charge to the customer. Any returns sent back to Well Traveled Living must be sent via prepaid freight and in the original retail packaging.

For warranty service contact Well Traveled Living at the address, phone numbers or internet site and email listed in this owner's manual. Be sure to have your sales receipt, date of purchase and catalogue/model numbers available when calling. All warranty service will be coordinated by the Well Traveled Living's, Amelia Island, Florida service center.

This warranty is extended only to the original purchaser. Proof of purchase will be required before warranty service is rendered. The sales receipt is the only valid proof of purchase. This warranty only covers failures due to defects in materials or workmanship which occur during normal use. Failures and/or damage which result from accident, negligence, misuse, abuse, neglect, mishandling, alteration or modification, failure to maintain, improper assembly or maintenance, service by unauthorized agency or use of unauthorized components or damage that is attributable to acts of God are NOT covered.

This limited warranty gives you specific legal rights and you may also have other rights which vary from jurisdiction to jurisdiction. The provisions of the United Nations Convention on Contracts for the Sales of Goods shall not apply to this limited warranty or the sale of products covered by this limited warranty.

- THERE ARE NO EXPRESS WARRANTIES EXCEPT AS LISTED ABOVE
- PURCHASER ASSUMES ALL RISKS IN THE ASSEMBLY AND OPERATION OF THIS UNIT
- FAILURE TO FOLLOW WARNINGS AND OPERATIONAL INSTRUCTIONS CONTAINED IN THIS MANUAL CAN RESULT IN SEVERE PROPERTY DAMAGE AND/OR PERSONAL INJURY
- IN NO EVENT WILL WELL TRAVELED LIVING, OR ITS DIRECTORS, OFFICERS OR AGENTS BE LIABLE TO THE PURCHASER OR ANY THIRD PARTY, WHETHER IN CONTRACT, IN TORT, OR ON ANY OTHER BASIS, FOR ANY INDIRECT, SPECIAL, PUNITIVE, EXEMPLARY, CONSEQUENTIAL, OR INCIDENTAL LOSS, COST, OR DAMAGE ARISING OUT OF OR IN CONNECTION WITH THE SALE, MAINTENANCE, USE, OR INABILITY TO USE THE PRODUCT, EVEN IF WELL TRAVELED LIVING OR ITS DIRECTORS, OFFICERS, OR AGENTS HAVE BEEN ADVISED OF THE POSSIBILITY OF SUCH LOSSES, COSTS, OR DAMAGES, OR IF SUCH LOSSES, COSTS, OR DAMAGES ARE FORESEEABLE. IN NO EVENT WILL WELL TRAVELED LIVING, OR ITS OFFICERS, DIRECTORS, OR AGENTS BE LIABLE FOR ANY DIRECT LOSSES, COSTS, OR DAMAGES THAT EXCEED THE PURCHASE PRICE OF THE PRODUCT.
- SOME JURISDICTIONS DO NOT ALLOW THE EXCLUSION OR LIMITATION OF INCIDENTAL OR CONSEQUENTIAL DAMAGES, SO THE ABOVE LIMITATION OR EXCLUSION MAY NOT APPLY TO THE PURCHASER.



### Important Notice

**Do not return to place of purchase**—for customer service and warranty issues contact our Customer Service Center at: **(866) 985-7877**, email us at [cservice@welltraveled.net](mailto:cservice@welltraveled.net), or go online and live chat at [www.wtliving.com](http://www.wtliving.com). Our hours are: **9 a.m. – 6 p.m., EST, Monday – Friday.**



Distributed By:  
Well Traveled Living  
716 S 8th Street, Amelia Island, FL 32034  
[wtliving.com](http://wtliving.com) | [cservice@welltraveled.net](mailto:cservice@welltraveled.net)  
(866) 985-7877