

Assembly Instruction

Item No.:500603-24
500603-30
500603-36

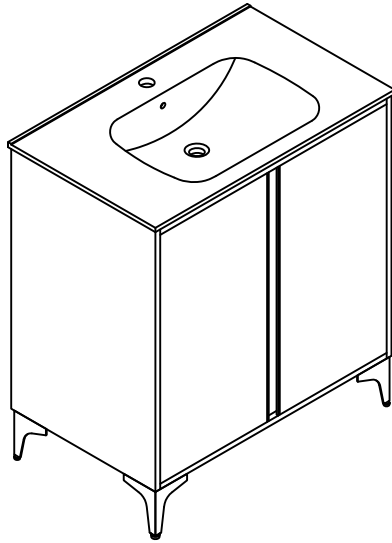

Components

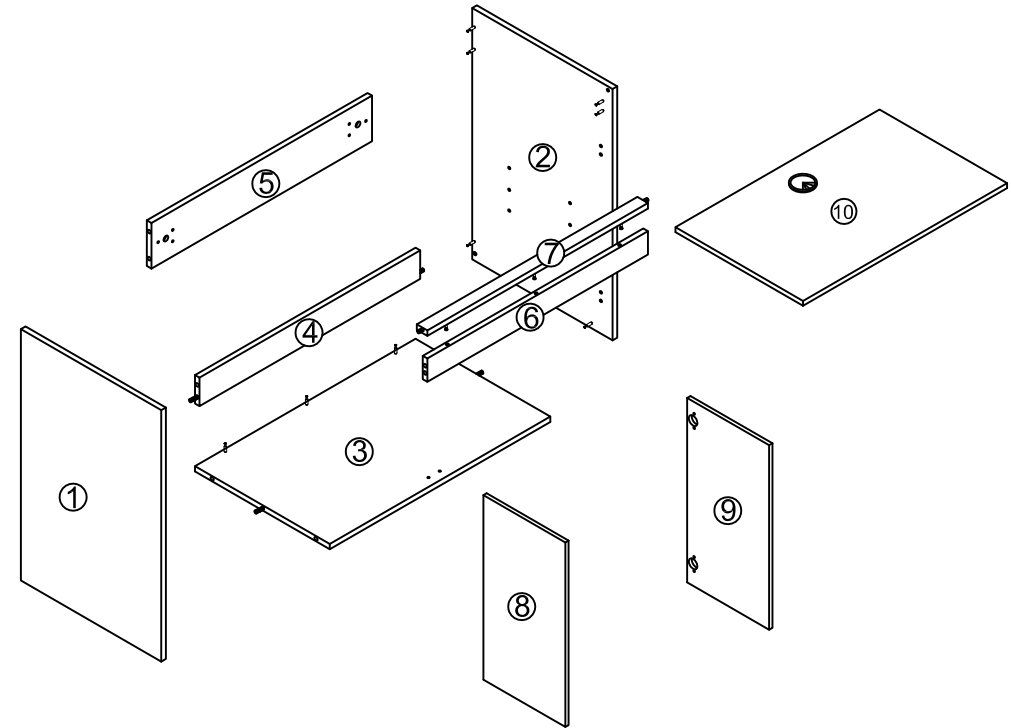

Hardware

NO.	Draw	QTY
A	Screws Ø4x14mm	44
B	Two-in-one connector	20
C	Two-in-one connector	20
D	Wood plug	6
E	Bracket (53x70x44mm)	2
F	Plastic anchor(Ø10mm)	2
G	Screws for fix on the wall	2
H	Door stopper	2
I	Bracket (19x19x35mm)	2

NO.	Draw	QTY
J	Hinges	4
K	Handle (YM3419B)	1
L	Handle (YM3418B)	1
M	Movable laminate support	4
N	Metal Feet	4
O	Screws M4x14mm	16
P	Anti-collision gasket	2
Q	Screwdriver	1

Recommended tools You Will Need-Outils Requis

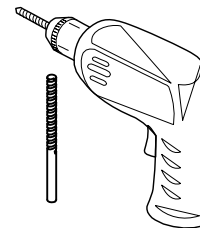

Power drill

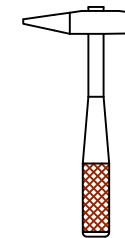

Hammer



Silicone

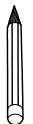





Pencil

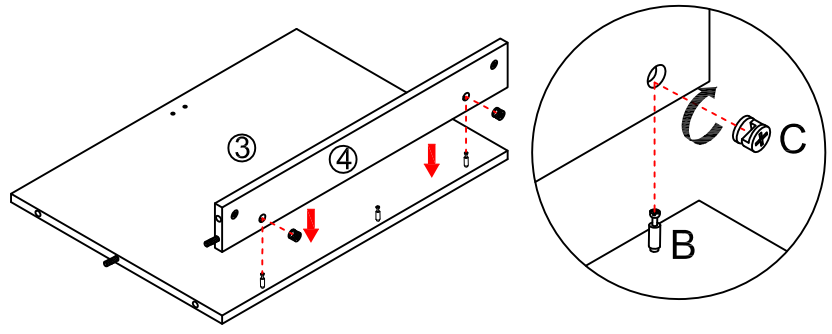

Screwdriver

Step 1



-  x3
-  x3
-  x1

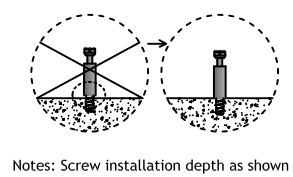
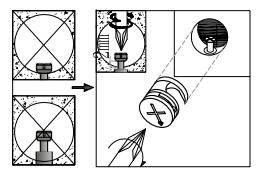

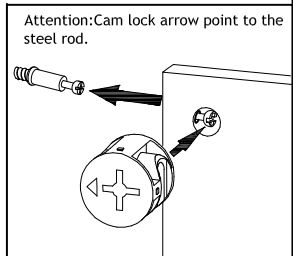

Notes: Screw installation depth as shown



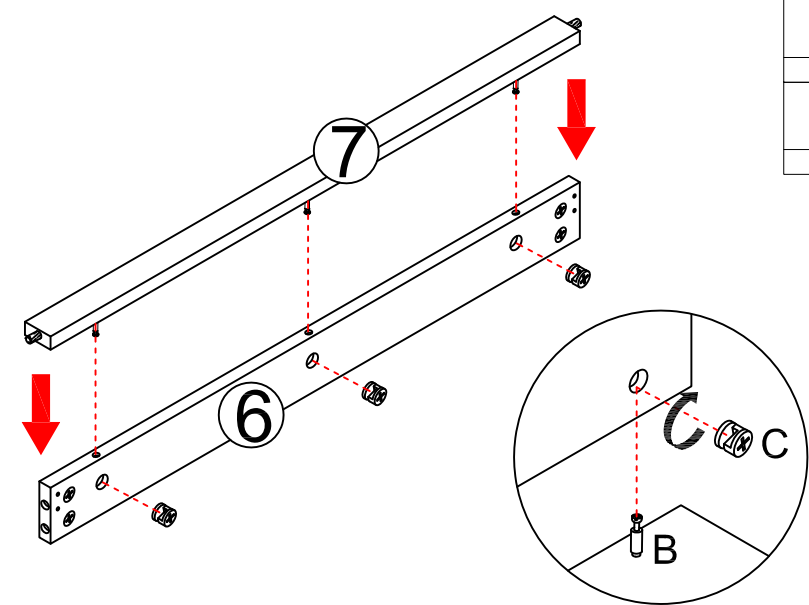



Step 3

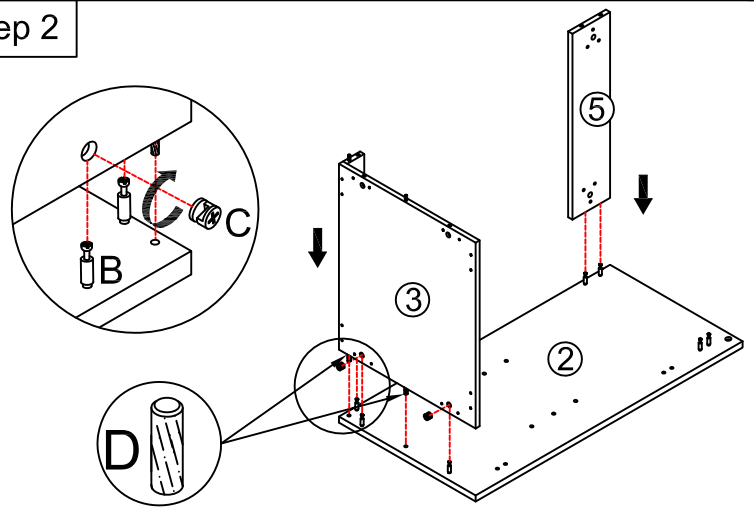

-  x3
-  x3
-  x1

Step 2





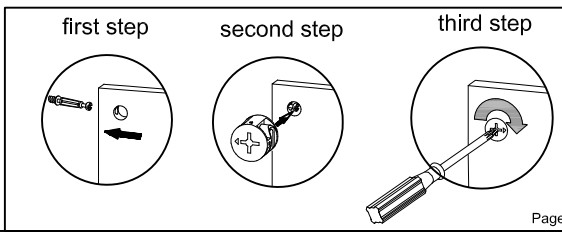
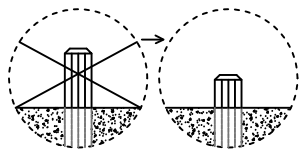

-  x5
-  x5
-  x2
-  x1

Note: The D parts are used for these two holes

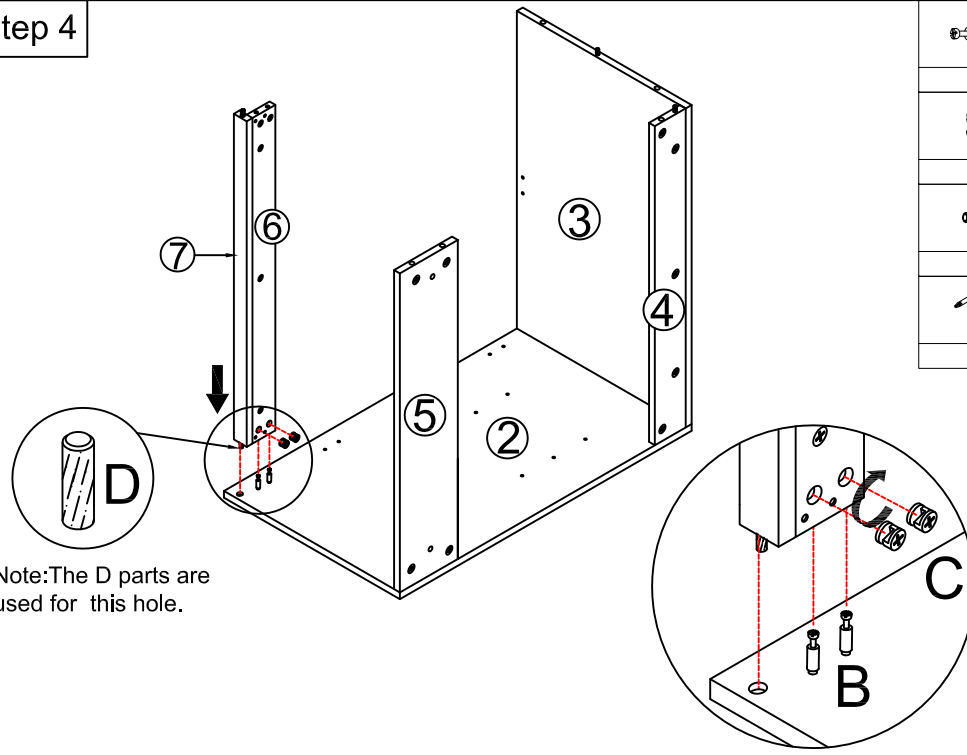

Step 4





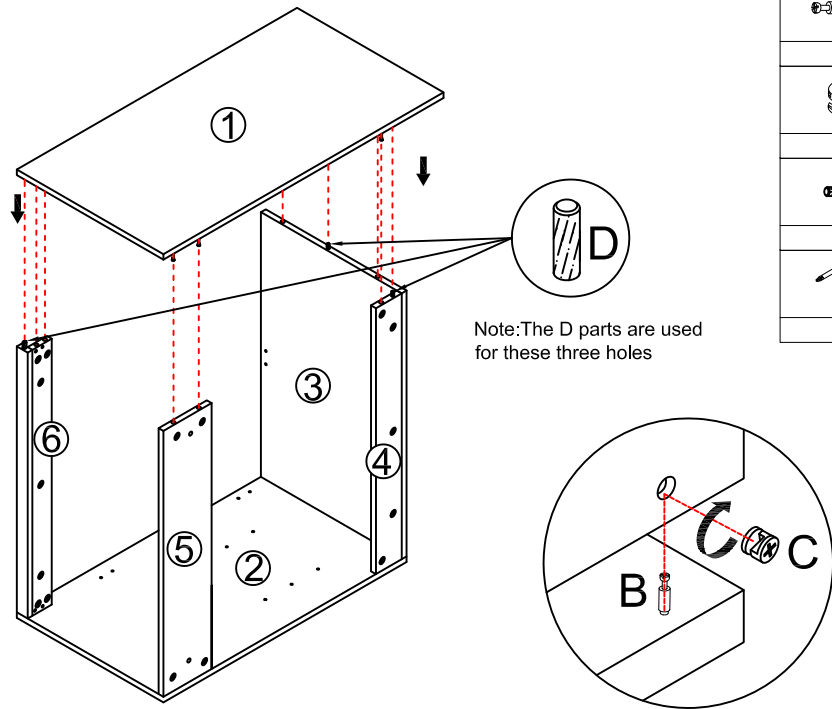

-  x2
-  x2
-  x1
-  x1

Note: The D parts are used for this hole.



Step 5



-  x7
- B**
-  x7
- C**
-  x3
- D**
-  x1
- Q**

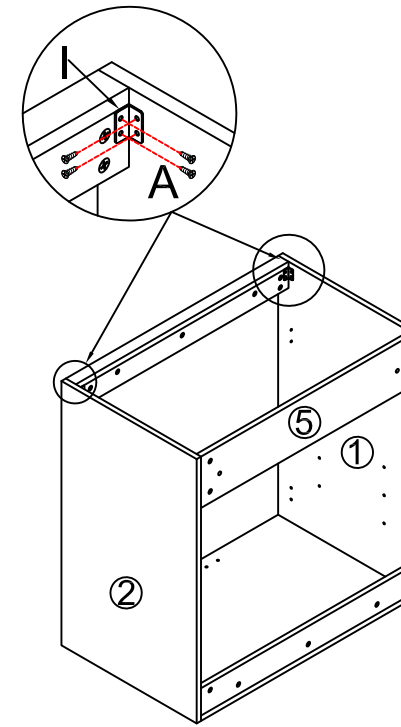

Step 7



-  x2
- I**
- (∅4 x 14mm)
-  x8
- A**
- 
- Tool**

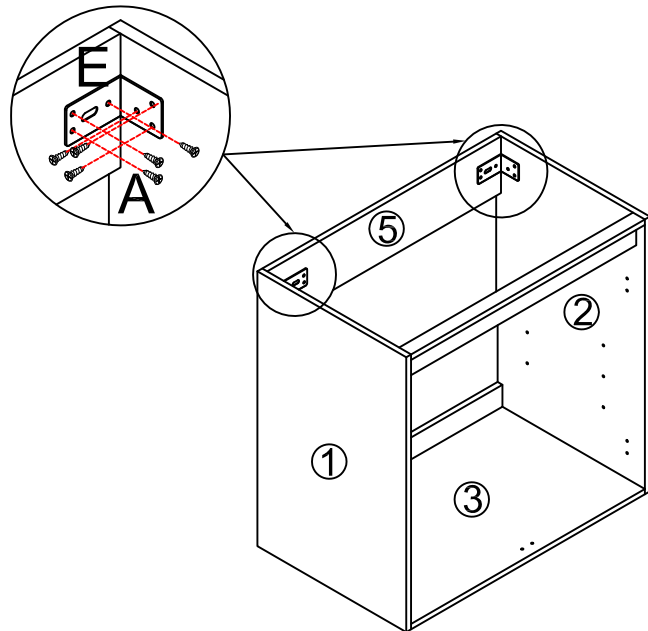



Step 6

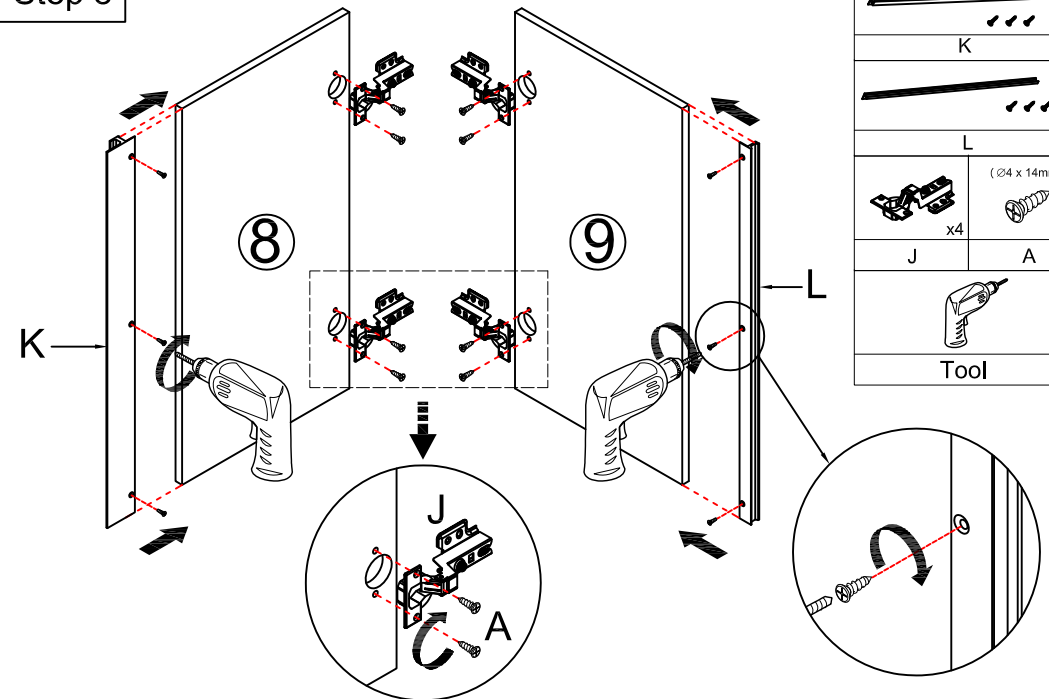

-  x2
- E**
- (∅4 x 14mm)
-  x12
- A**
- 
- Tool**



Step 8

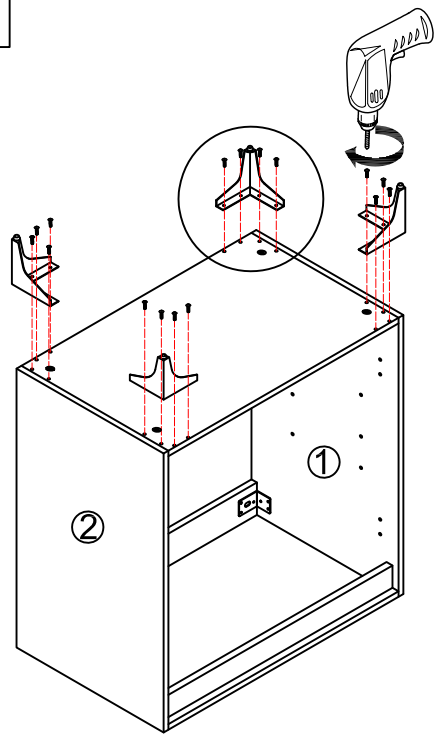

-  x1
- K**
-  x1
- L**
- (∅4 x 14mm)
-  x4
-  x8
- A**
- 
- Tool**

Step 9



-  x4
- N
- (M4 x 14mm)
-  x16
- O
-  Tool

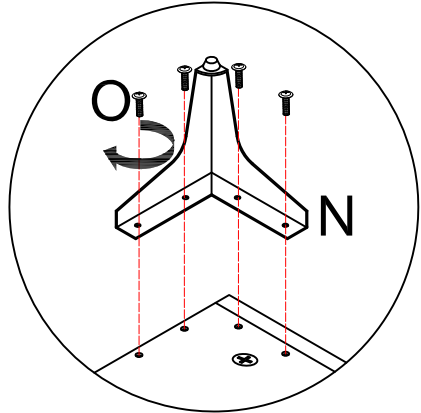



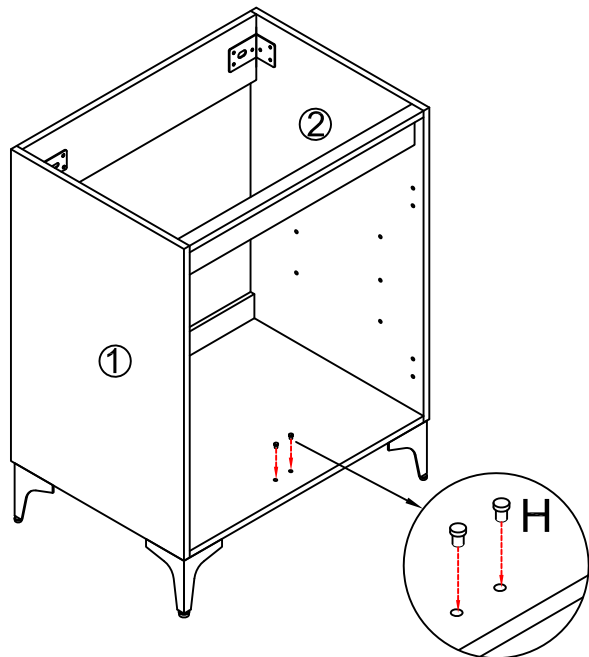

Step 10

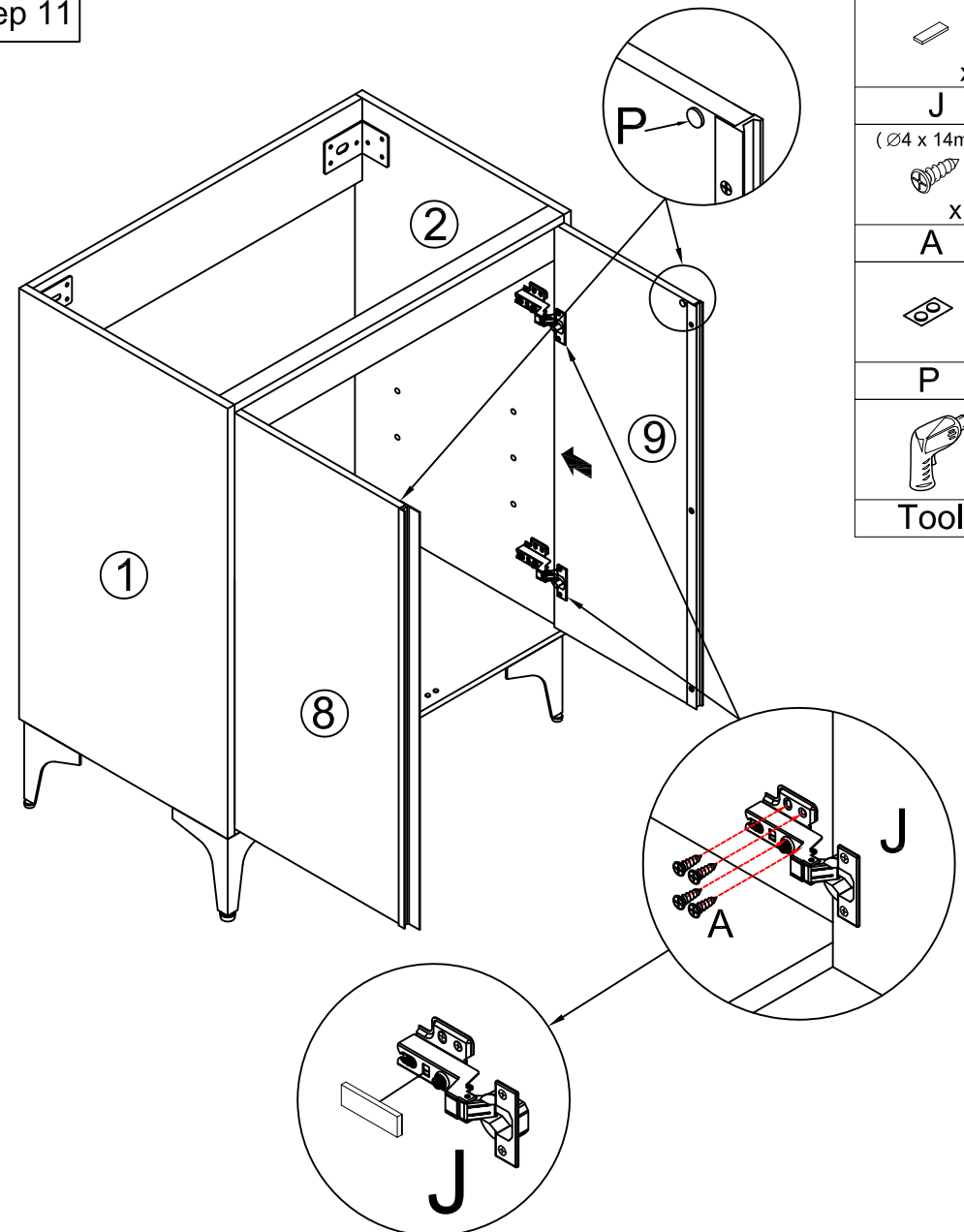

-  x2
- H

Step 11



-  x4
- J
- (Ø4 x 14mm)
-  x16
- A
- 
- P
-  Tool

You can adjust the doors by tightening or loosening the screws on the hinge. →

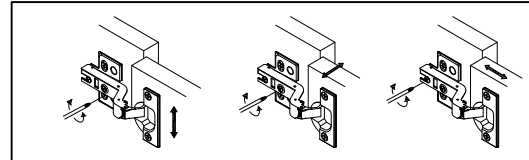

Step 12

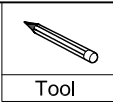

Wall
+

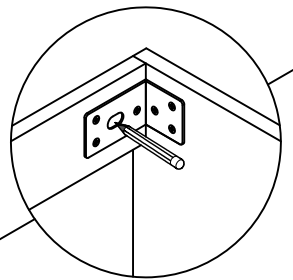
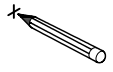

Step 13



Wall
.

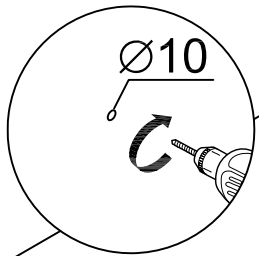

Step 15

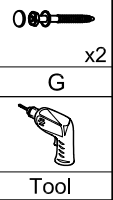
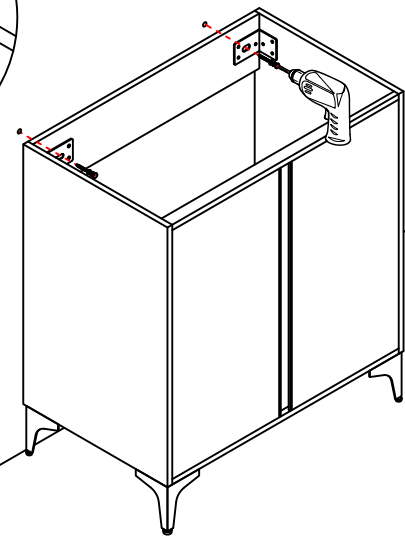
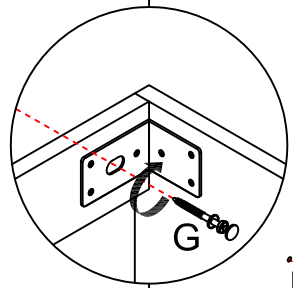

Step 14

Wall

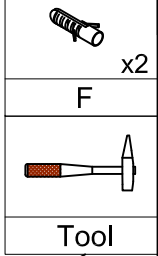
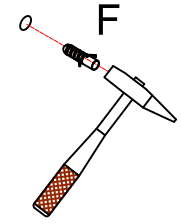

Step 16

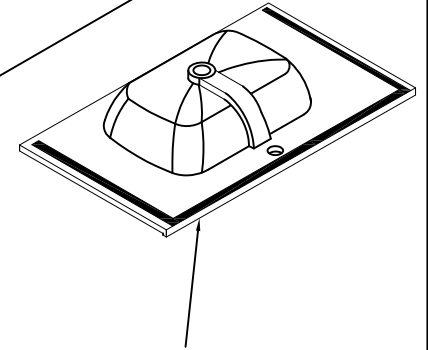
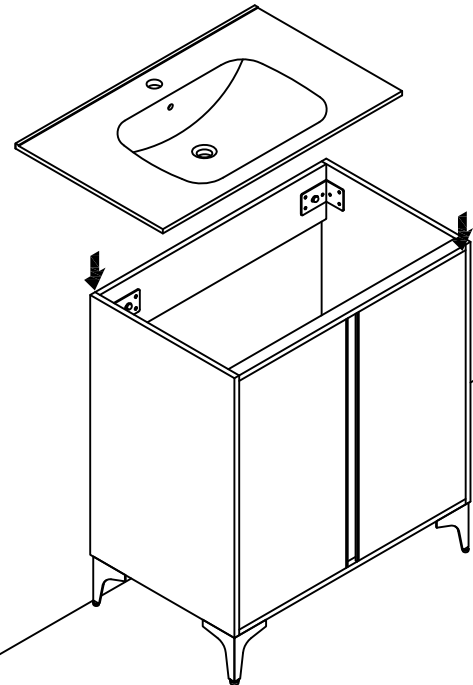

Remove the protective surface of 3M tape from the basin bottom and attach to the cabinet.

Step 17



x4

M

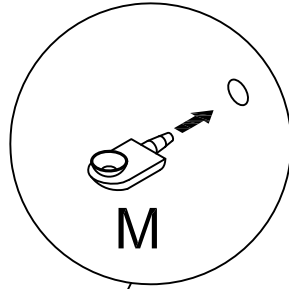

M

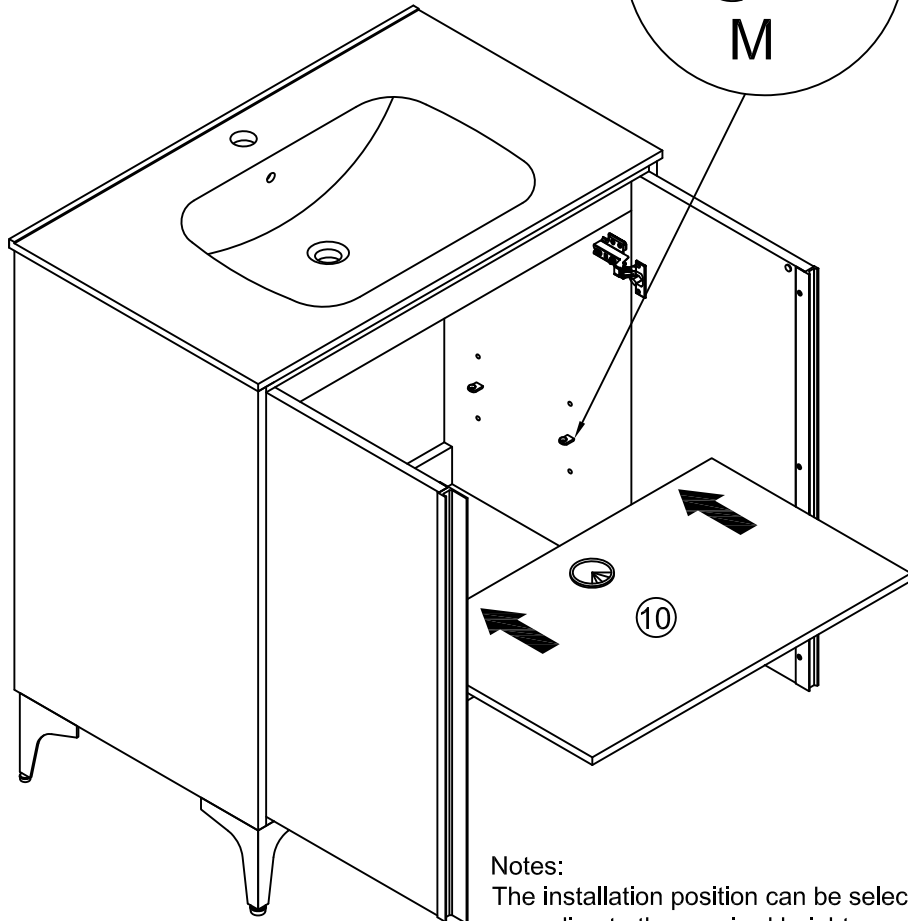

Notes:
The installation position can be selected according to the required height.

Finished

