

Kräus®

INSTALLATION MANUAL

Britt™ Single Handle Commercial Kitchen Faucet

KPF-1690

Congratulations on the purchase of your new Kraus® plumbing fixture!

Please keep the box and packaging materials until your product is completely installed. If you have any questions, require technical assistance or have any problems with your product:



DO NOT RETURN TO STORE

**Please contact our Customer Service Team
1-800-775-0703 / customerservice@kraususa.com**

Have the model number available and retain a copy of your receipt with purchase date for reference.

If for any reason this product does not meet your expectations, please be sure to repack this product in the original box and packaging material to avoid damage during transit.

STOP

Prior to Installation:

- Make sure you have all necessary parts by checking the diagram and parts list. If any part is missing or damaged, please contact Kraus[®] Customer Service at 800-775-0703 for a replacement.
- Read all instructions and safety warnings and ensure you have all tools, parts, and equipment necessary for a safe installation.
- Turn off the hot and cold water supply at the angle stops and turn on the old faucet to release any built up pressure. Remove existing faucet.
- Pre-drilled hole size requirement: 1 3/8" (min)
- Max countertop thickness: 3"

For technical assistance or replacement parts, please contact Kraus Customer Service and one of our representatives will be happy to help:

Toll-Free: 800-775-0703 or Customerservice@kraususa.com

Tools Required

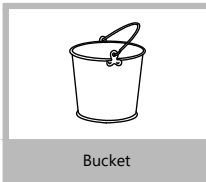
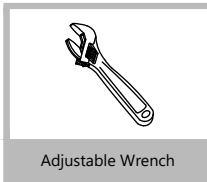

Care & Maintenance

- * To keep the product clean & shining, follow the steps below:
 1. Rinse with clean water & dry with a soft cloth
 2. Do not clean with soaps, acid, polish, abrasives or harsh cleaners
 3. Do not use cloth with a coarse surface
 4. Unscrew the aerator and clean when necessary
- * This installation manual is subject to change without further notice.



Diagram and Parts List

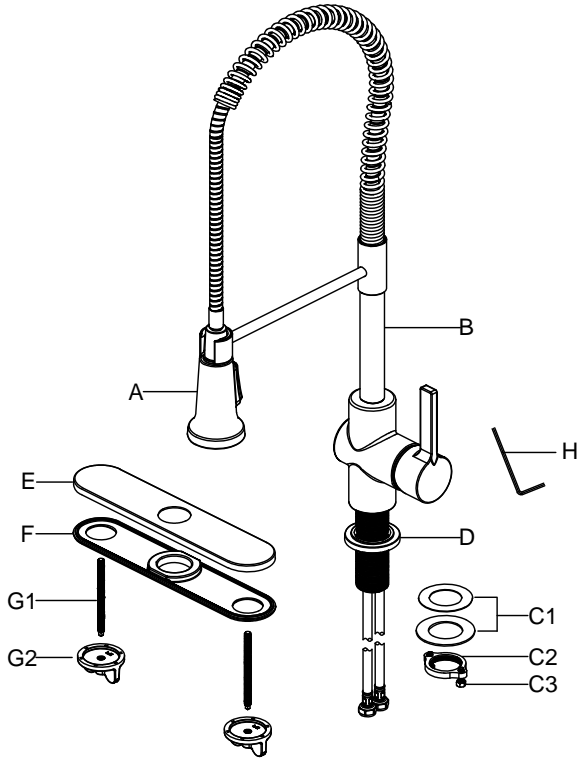

A. Spray Head

B. Faucet Body

C. Mounting Hardware

C1. Rubber & Metal Washer

C2. Mounting Nut

C3. Mounting Screw

D. Flange & Washer

E. Escutcheon

F. Base Plate

G. Escutcheon Mounting Hardware

G1. Bolt

G2. Plastic Nut

H. 2.5 mm Hex Wrench

Faucet Dimensions

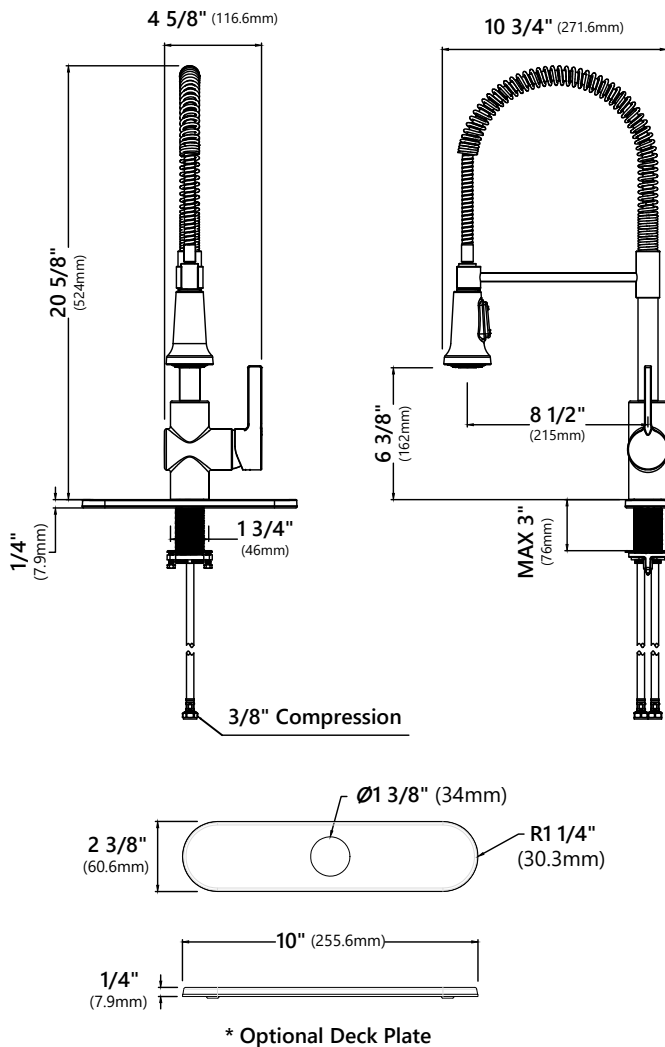

Installer Tip:

Shut off main water supply before installing new faucet.

Step 1. Remove mounting hardware

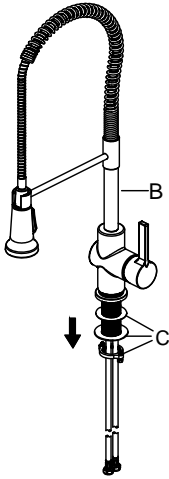

Shut off the water supply. Remove the old faucet. Clean the mounting surface. Remove the mounting hardware (C) from the faucet body (B).

Step 2. Install the faucet assembly (without deckplate)

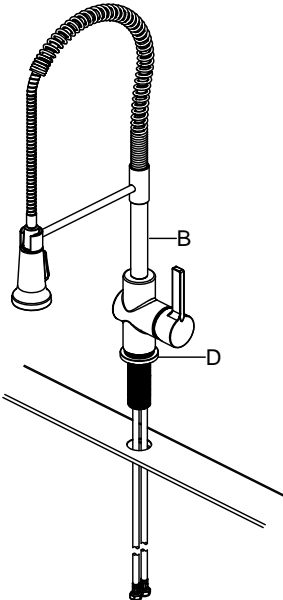

Before installation, ensure that the flange (D) is placed on the bottom of the new faucet assembly (B). Insert the faucet body through the hole in the sink or countertop.

NOTE: Skip this step and move on to Step 3 if installing with deckplate.

Step 3. Install the escutcheon

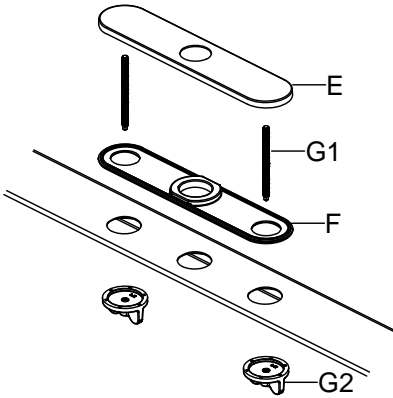

Before installation, remove the flange (D). Screw the bolts (G1) into the escutcheon (E) and ensure that the base plate (F) is pressed onto the escutcheon (E) before the escutcheon (E) is installed over the three holes on the sink. From underneath the sink or countertop, hand tighten the mounting nuts (G2). Do not overtighten. **NOTE:** Skip this step if installing without deckplate.

Step 4. Install the faucet assembly (with deckplate)

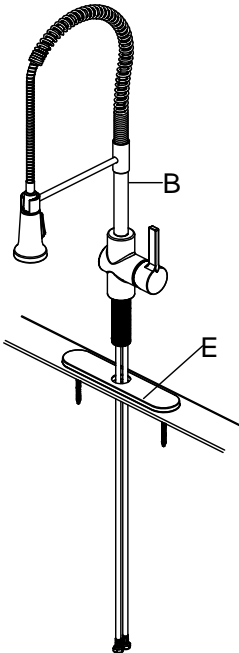

Insert the faucet assembly (B) through the hole in the escutcheon (E). **NOTE:** Skip this step if installing without deckplate.

Step 5. Secure the faucet assembly

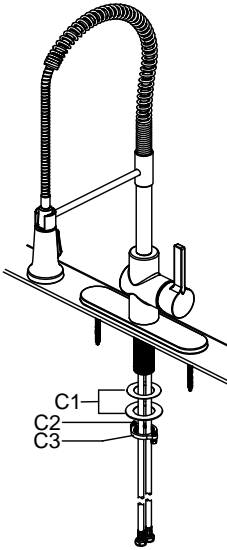

Install the plastic washer and metal washer (C1) onto the threaded mounting shank. Thread the nut (C2) onto the mounting shank. Lock the nut (C2) into position by tightening the screws (C3).
Do not overtighten.

Step 6. Connect the waterlines

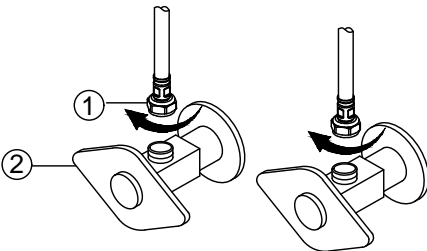

Thread the nut (1) on the supply line onto the outlet of the water supply valve (2) and tighten with wrench. Do not overtighten.

NOTE: Please make sure filter washers are installed before connecting to the main valve.

Step 7. Flush and check for leaks

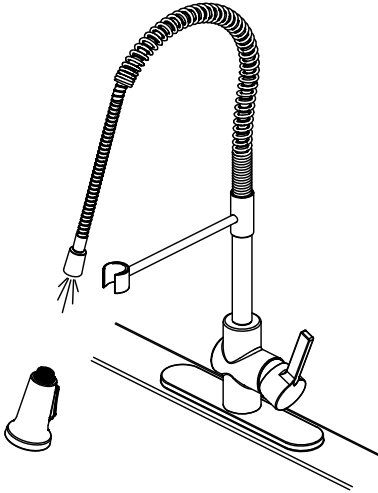

Pull the hose assembly out of the spout and remove the spray head by unscrewing it from the hose in a counterclockwise direction. Hold the end of the hose down into the sink and turn the faucet on to the warm position. Flush water lines for one minute to flush away any debris. Check for leaks. Retighten any connections if needed. Do not overtighten. Reinstall the spray head by hand tightening it back onto the spray hose. After installation is completed, turn on the hot and cold water supplies to check for leaks.

Replacement Parts

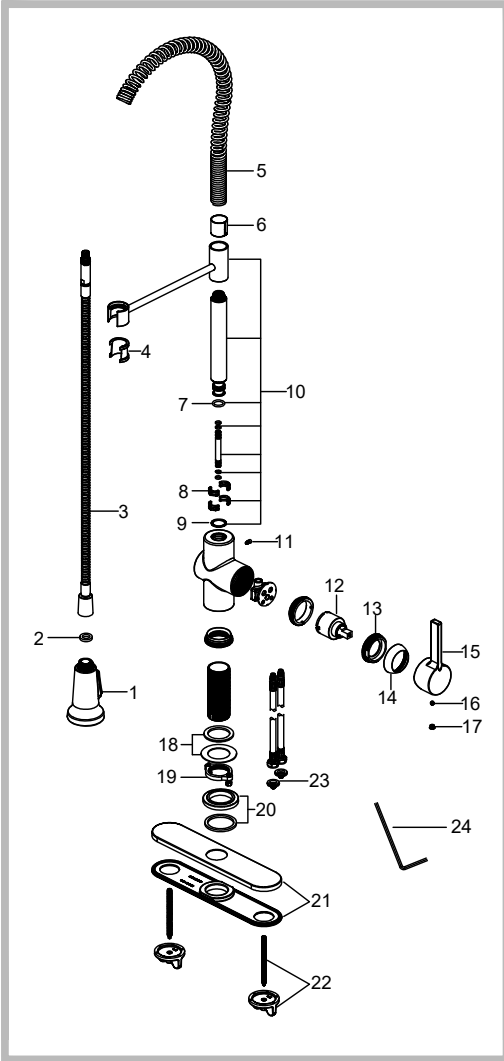

Replacement Parts List	Finish/Color	Part #
1. Spray Head	SFS,BG,SFACB,SFSB,MB,AB**	KP27478
2. Washer		KP27479
3. Sprayer Hose	BLAB,BLBG,BLSFSB BLMB,BLSFACB,SFS*	KP27025
4. Inverter	GR,BL**	KP27026
5. Spring	SFS,BG,SFACB,SFSB,AB**	KP27027
6. Inverter	GR,BL**	KP27080
7. O-ring		KP27029
8. Block		KP27030
9. Washer	GR,BL*	KP27031
10. Spray Support Assembly	SFS,AB,BG,SFSBMB SFACB,SFACBMB,BGMB**	KP27032
11. Set Screw		KP27033
12. Cartridge		KP27035
13. Bonnet Nut		KP27036
14. Cap	SFS,BG,SFACB,SFSB,AB**	KP27037
15. Handle	SFS,BG,SFACB,SFSB,AB**	KP27038
16. Set Screw		KP27001
17. Cover Button	GR,BL**	KP27002
18. Rubber & Metal Washer		KP27028
19. Nut & Screw		KP27079
20. Flange	SFS,BG,SFACB,SFSB,AB**	KP27041
21. Escutcheon	SFS,BG,SFACB,SFSB,AB**	KP27184
22. Escutcheon Mounting Hardware		KP27185
23. Filter Washer		KP27167
24. 2.5mm Hex Wrench		KP27020

*Denotes spray hose assembly color options:
 Spray hose assembly color options:
 Black hose with Matte Black connector (BLMB);
 Black hose with Spot-Free Antique Champagne
 Bronze connector (BLSFACB); Spot-Free Stainless
 Steel hose with Spot-Free Stainless Steel
 connector (SFS); Black hose with Spot-Free Black
 Stainless connector (BLSFSB); Black hose with
 Brushed Gold connector (BLBG); Black hose with
 Antique Brass connector (BLAB)

**Denotes faucet component color options:
 SFS - Spot Free Stainless Steel
 MB - Matte Black
 BG - Brushed Gold
 SFACB - Spot Free Antique Champagne Bronze
 SFSB - Spot Free Black Stainless
 AB - Antique Brass
 BL - Black
 GR - Gray

Troubleshooting

If you have followed the instructions carefully and your faucet still does not work properly, take the following corrective steps:

PROBLEM	CAUSE	ACTION
Leakage under faucet handle	The bonnet nut (13) has come loose and the ring on the cartridge is dirty or damaged	Tighten the bonnet nut. Clean or replace the cartridge
Leaking between spray head and the hose	Spray head (1) may be loose or washer (2) is not seated correctly in the hose connection.	Tighten spray head (1) by hand until snug. Make sure washer (2) is seated correctly
The water pressure is low	Waterlines may be clogged	Turn off the water supply at water valves and unscrew the hose connectors from water supply lines. Clean the screens in the water lines with hot water, removing any debris or calcium build up.

Codes/Standards Applicable:



NSF/ANSI 61



ASME A112.18.1
1.8GPM 6.8L/min maximum

Faucet - Lifetime Limited Warranty

Kraus® USA Plumbing, LLC ("Kraus") extends this warranty to the original purchaser for personal household use of the Faucet when purchased from an authorized Kraus dealer and in the location of original installation. This warranty is non-transferable.

Kraus warrants the structure and finish of the Faucet to be free from defects in material and workmanship under normal usage for as long as the original purchaser resides in the residence in which the Faucet was first installed.

Kraus warrants the Faucet's sprayhead assembly (including the engine, aerators, structure, restrictors, back flow preventers, sprayer hoses, braided supply line hoses which encompasses nylon, silicon and stainless steel) of the product to be free from defects in material and workmanship under normal usage for a period of one (1) year from the date of purchase.

Kraus warrants the Faucet's cartridge to be free from defects in material and workmanship under normal usage for a period of five (5) years from the date of purchase.

Any product reported to the authorized dealer or to Kraus as being defective within the warranty period will be repaired or replaced with a product of equal value at the option of Kraus.

Commercial Warranty

Kraus USA Plumbing, LLC ("Kraus") warrants its Products for a period of one (1) year to commercial purchasers of Products used in industrial, commercial and business applications.

Care and Cleaning Instructions

Certain cleaning products may cause damage to a Product's finish and use of the following on the Product will void this warranty:

- Abrasive cleaners such as powders, bleach, ammonia, alcohol or chlorine
- Abrasive pads, steel wool or wire brushes

What is Not Covered

This warranty does not cover Products that were discontinued when purchased or display Products, whether such Products were purchased at discount outlets, unauthorized dealers, and/or sold on clearance. This warranty does not cover any free gifts included with purchase.

This warranty does not cover damage resulting from neglect, misuse (including use for an unintended application), abuse, carelessness, accident, hard water or mineral deposits, exposure to corrosive materials, improper maintenance, alteration of the Product, or failure to follow care, cleaning or installation instructions enclosed with your Product. Kraus recommends that all Kraus Products be installed by a fully licensed and insured trade professional with experience in the installation of bathroom and/or kitchen manufactured goods.

How to Make a Warranty Claim

If you are a **consumer purchaser**, please contact a Kraus® Customer Service Representative at:

Kraus USA Plumbing, LLC
12 Harbor Park Drive
Port Washington, NY 11050
Toll-free 800-775-0703
Customerservice@kraususa.com

If you are a **plumbing contractor or trade professional**, please contact a Kraus Pro Representative at:

Kraus USA Plumbing, LLC
12 Harbor Park Drive
Port Washington, NY 11050
516-801-8955
Proservice@kraususa.com

If you are an **authorized partner**, please contact a Partner Support Representative at:

Kraus USA Plumbing, LLC
12 Harbor Park Drive
Port Washington, NY 11050
516-801-8954
Partnersupport@kraususa.com

In requesting warranty service, please be ready to provide your proof of purchase and a description of the problem. Shipping charges will be covered for the first (1) year of the warranted replacement part or product (HI, AK, and Puerto Rico shipping charges may apply). International shipping fees are not included.

Limitation on Duration of Implied Warranties

Please note that some states/provinces (including Quebec) do not allow limitations on how long an implied warranty lasts, so the below limitations may not apply to you. TO THE MAXIMUM EXTENT PERMITTED BY APPLICABLE LAW, ANY IMPLIED WARRANTY, INCLUDING THE IMPLIED WARRANTIES OF MERCHANTABILITY AND OF FITNESS FOR A PARTICULAR PURPOSE, IS LIMITED TO THE STATUTORY PERIOD OR THE DURATION OF THIS WARRANTY, WHICHEVER IS SHORTER.

Limitation of Special, Incidental or Consequential Damages

Please note that some states/provinces (including Quebec) do not allow the exclusion or limitation of special, incidental or consequential damages, so the below limitations and exclusions may not apply to you. TO THE MAXIMUM EXTENT PERMITTED BY APPLICABLE LAW, THIS WARRANTY DOES NOT COVER, AND KRAUS USA PLUMBING, LLC SHALL NOT BE LIABLE FOR, ANY SPECIAL, INCIDENTAL OR CONSEQUENTIAL DAMAGES (INCLUDING LABOR CHARGES TO REPAIR, REPLACE, INSTALL OR REMOVE THIS PRODUCT), WHETHER ARISING OUT OF BREACH OF ANY EXPRESS OR IMPLIED WARRANTY, BREACH OF CONTRACT, TORT, OR OTHERWISE.

This warranty gives you specific legal rights, and you may also have other rights which vary from state/province to state/province.

Download the Kraus Care & Maintenance Guide at:
<http://www.kraususa.com/maintenance>

IMPORTANT

Register Your Kraus Product

Activate Your Warranty

Access Premium Customer Support

Get Product Information

REGISTER TODAY

<http://www.kraususa.com/registration>



Kräus[®]
www.kraususa.com