

# RANGE HOOD

## SPECIFICATIONS

MODEL# COS-5MU36

### FEATURES

DESIGNED FOR UNDER CABINET MOUNTING

3 FAN SPEEDS

EFFICIENT AIRFLOW CAPACITY

PUSH BUTTON CONTROLS

3 CLEAR-FLOW® MESH FILTERS

BACK LED LIGHTS

56 dB FOR QUIET OPERATION

TOP OR BACK VENTED



The perfect piece for any contemporary kitchen, Cosmo's COS-5MU36 is powered by efficient airflow suction, LED lighting and CLEAR-FLOW® Mesh Filters.

SEE PAGE 2 FOR DIMENSIONS



Size	36 Inch
Mounting Type	Under Cabinet
Controls	Push Button
Filters	3x Aluminum Mesh Filters
Material	430 Grade Stainless Steel
Air Flow	Efficient
Noise Level	56dB (Max)

Vent Style	External
Lighting	2x Back 3W LEDs
Voltage	120V / 60Hz
Wattage	140W
Included Components	Bulb(s), Damper, Exhaust Vent, Fan Hardware, Installation Kit, Power Cord



# RANGE HOOD

MODEL# COS-5MU36

# DIMENSIONS

Assembled Product Dimensions

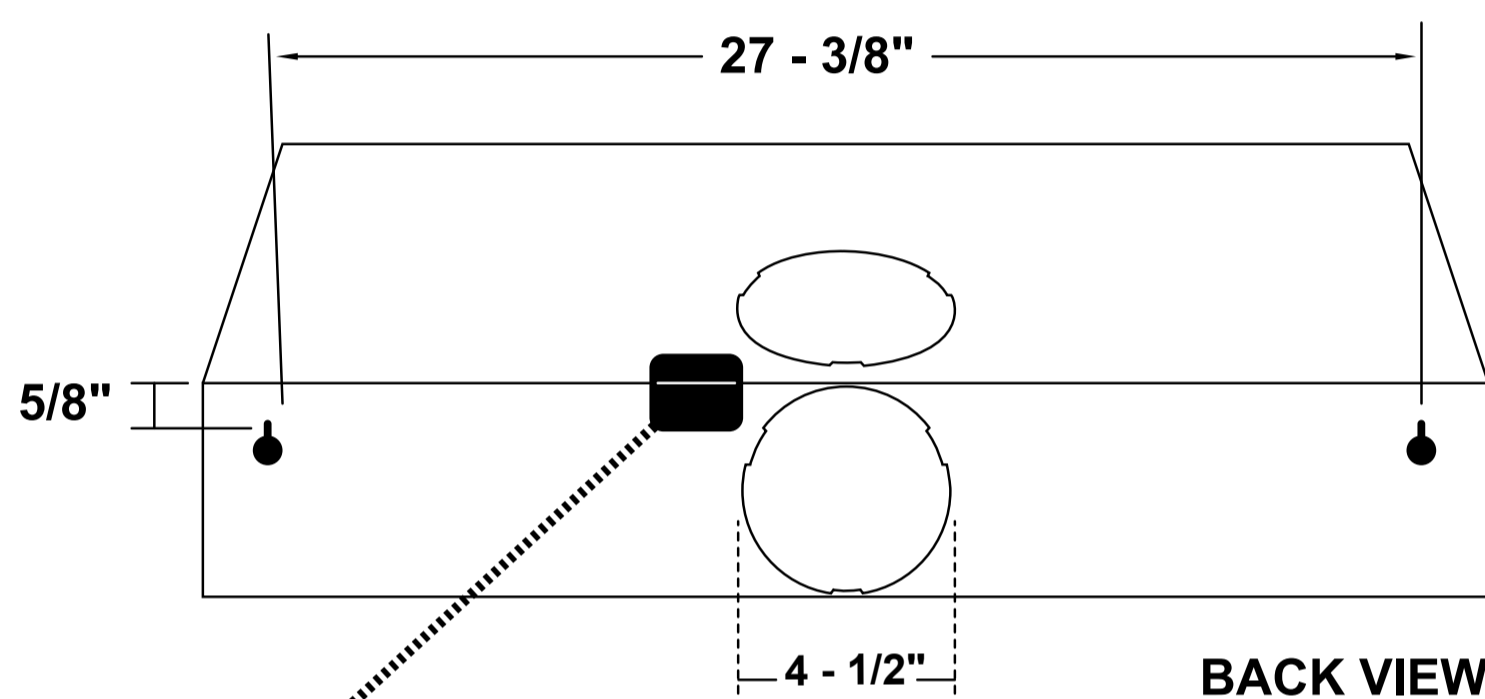
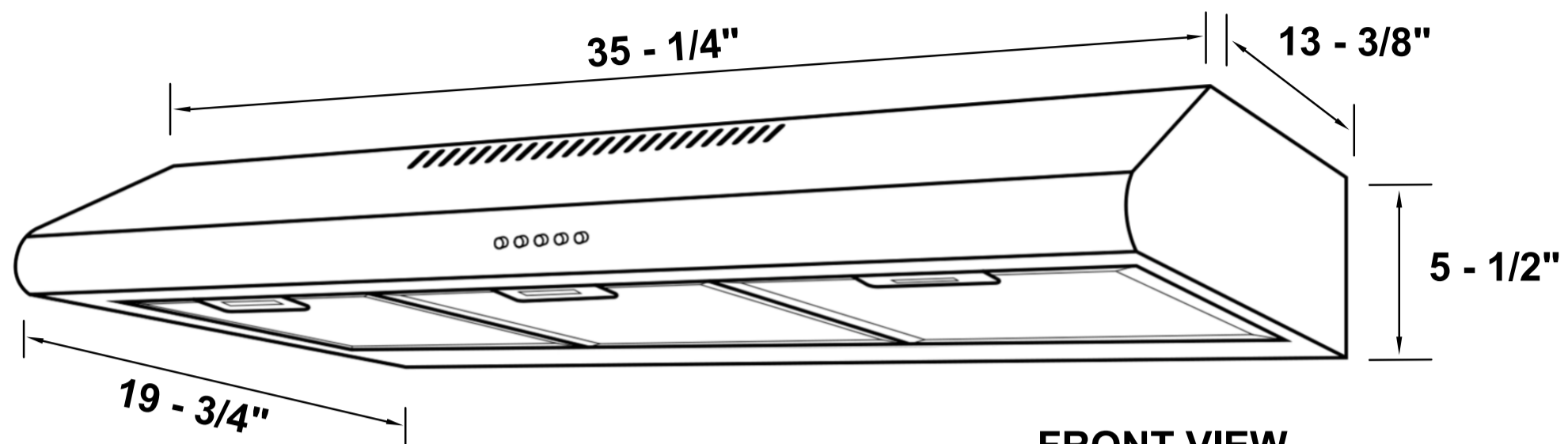

Location of  
3-Prong Plug

**NOTE:** Ventilation outlet is 4 - 1/2" in diameter. A 5" duct is recommended for installation.

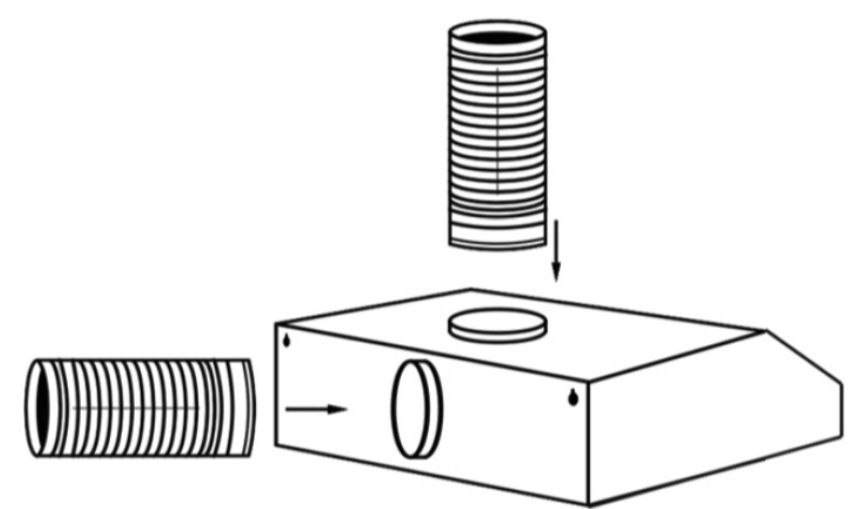

TOP or REAR Vent Options

