



## EE112W series User Manual

**Please Read Carefully Before Installing the Unit!**

### Introduction and Intellectual property Rights Statement

Thank you for choosing the EE112WMC (built with RF-sensor) and EE112W (without RF-sensor) LED SMART light series. With its effortless setup and lightweight design, the EE112WMC and EE112W LED Smart Lights conforms to all your lighting needs. With lightweight design, our product is easy to setup and can be use to meet diverse lighting requirements It was designed and made to provide long-term trouble free service with environment friendly LED-illumination and Doppler Sensing technology. Covered under multiple US, European, China and other international patents granted and pending worldwide. All rights reserved. Contents:

- What's Inside the Package
- Installation
- Functions
- User Tips
- Specifications
- Optional Accessories
- Important Safety Information
- Limited Warranty Information

### The Package

1 - LED Sensing Light Unit    4 - Hardware Package with Screws and Anchors to mount the light body    1 - White frosted light face cover

### Applications

#### Outdoor/Indoor Weatherproof, AC powered LED Light, with "All in One" Operating Capability:

**Standard** - Can be used as a switch-controlled or AC power always ON lighting to new lighting project or like DIY to replace existing outdated light features. It serves as a standard application that provide continuous illumination in any conditions.

**Doppler Sensing (EE812WMC capable)** - Provides outstanding motion sensing performance and Unlike PIR motion detection, this product can effectively sense the temperature changes in its surroundings, and without being blocked by obstacles.

**Smart Sensor Profiles (EE812WMC capable)** - Users are offered with two selectable energy-saving lighting modes. In "Auto Off" mode, the light will be turned off automatically if the motion sensor doesn't detect any movement across its coverage area. In "Gradually Dimming Lighting" mode, the light will dimmed down to preset light level (fixed 20% of Max brightness) when no motion has been detected.

**Dusk to Dawn Illumination**- The lighting feature also offers standard, automatic Dusk to Dawn lighting profile if the light is connected with AC power ON all the time. In such case, any manual settings and extra photo cell sensor can be waived. During nighttime, it will automatically turn on and keep dusk to dawn operation for the whole night. A built-in photo sensor allows users to set up the lighting mode based on their preference. Users can set up the lights only turn on at evening or keep working during partial daylight condition.

#### The Reference of Wiring Diagram for Standard AC Lighting for Switch ON-OFF Control: (Fig. 1) and Fixed AC Power Source Lighting for Commercial, Industrial or Public Facilities: (Fig. 2)

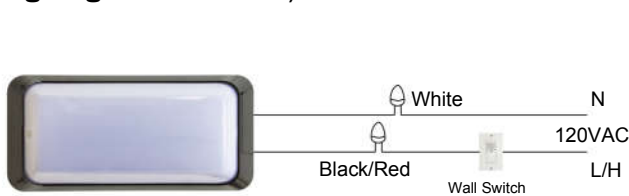

Individual New or Replacement Application

Fig. 1

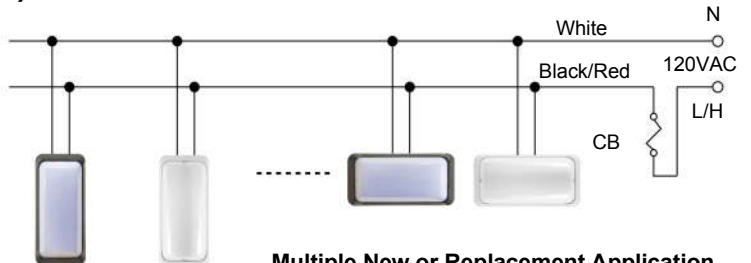

Multiple New or Replacement Application

Fig. 2

### • Installation

#### • Mount & Setup (Turn power OFF before installing)

Remove the fixture cover and the LED board before you installing. Screw the light fixture base onto the pre-installed/existing electric standard J-Box and connect power wires (N & L /H) into the terminals, refer: Fig. 1, 3-6. For concrete/brick/stucco surface without the J-Box: It is best to drill clearance holes using a 3/16" masonry bit then insert plastic anchors and screw the base into position. Make sure mounting is secured and safe by your local electric code. Then power ON as general lighting control for normal lighting function.

#### • Apply as Standard Light

Connect with AC power source (120V AC) as standard single or group lighting system. The light (s) can be manually turned ON and OFF via a standard wall mounted switch as general lighting, and plus its motion activated or saving pre-set dimming function profiles if no any movement around coverage areas (refer: Fig. 1).

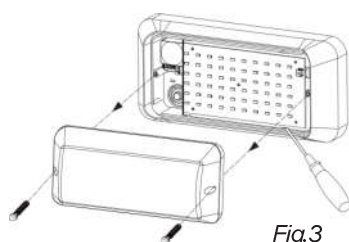

Fig.3

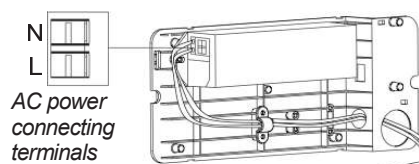

Fig.4

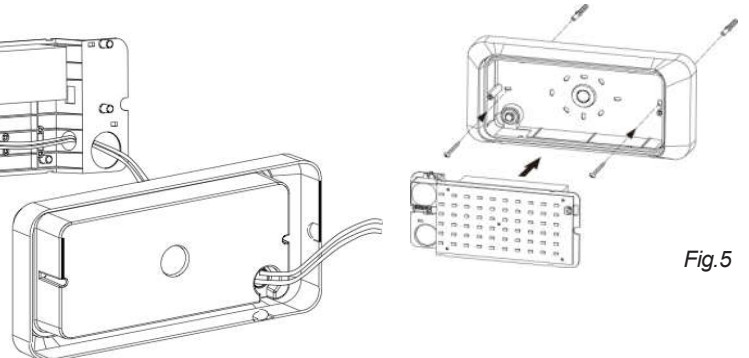

Fig.5

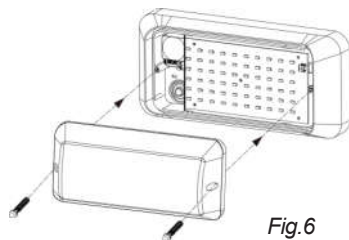

Fig.6

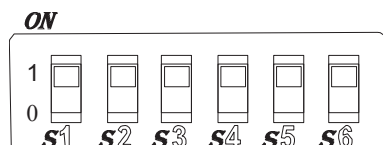
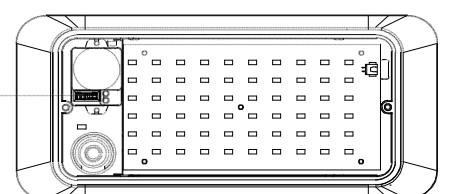

Fig.7 Dip switches setting reference



● **Apply as Dusk to Dawn Automatic SMART Activity Lights**

When the light is installed in such: hallway/corridor, stairway, restroom, lobby and any public areas, connect the light with AC power is just as easy as replace the existing light system or for new installation project. Make sure the AC power is ON all the time and the light will operated as pre-set lighting profile. (refer: Fig. 2 and 7, 8)

● **Doppler Motion Detecting Range/Sensitivity Adjustment (Dip switch S1 and S2 Setup)**

By Dip switch 1 and 2 to set your preference of the coverage range/sensitivity of motion detection. Unlike other types of motion sensors (PIR e.g.), Doppler/Microwave sensor can detect through most nonmetallic blocking obstacles, therefore the movement is detected before coming into the area covered with motion sensitivity and the lighting response has no delay. Its average coverage area has a controllable range of around 7 to 25 feet diameter when mounted at a height of 8-10 feet. (refer: Fig. 7, 8)

● **Delay Timer (Dip switch S3 and S4 Setup)**

The light can be set to functionally stay ON for any period of time between approx 10 sec. to maximum of 12 min as traditional motion activated light, by Dip switch 3 and 4 to select. Any movement detected during this time elapse will re-set the timer. It is recommended to select the shortest time for adjusting the Sensitivity detection performance via the walk test, after this testing it is recommended to set back to maximum position. (refer: Fig. 7, 8)

● **Operating Ambient Light Level (Dip switch S5 Setup)**

By Dip switch 5 to set with "0" position when the illumination is started depending on the level of environmental darkness at night or with "1" position for daylight level and the occupancy area as desired. (refer: Fig. 7, 8)

● **Auto Dimming Down as Power SMART Saving & Safety Mode (Dip switch S6 Setup)**

By Dip switch 6 setting with "1" for the dimming moonlight profile all night long, this light can automatically dim down its illumination brightness level to fixed 20% of maximum level after the expired delay period when no movement is detected, then it will run up to the maximum illumination level when any movement is detected in the coverage area, it is always provide a unique safety and environmental friendly lighting profile. (refer: Fig. 7, 8)

● **Motion Activated as Energy Saving or Traditional Security Sensing Mode (Dip switch S6 Setup)**

By setting Dip switch 6 with "0" position, then this light can automatically shut OFF after expired delay period (as traditional motion light function) when no movement is detected, then it will light-up with MAX brightness illumination when any movement is detected in the coverage area. (refer: Fig. 7, 8)

Range and Sensitivity Setting			Delay Time Setting			Lighting Profile Setting		
S1	S2		S3	S4		S5	S6	
0	0	7'	0	0	10Sec	0		DUSK
0	1	13'	0	1	2min	1		DayLight
1	0	20'	1	0	6min		0	AUTO
1	1	25'	1	1	12min		1	SMART

Fig.8 Lighting Functions and Profiles Setup

**User Tips and Warning!**

- **Shut off the main AC power before starting installation.**
- Keep it away from the children during the installation.
- Avoid installing where the temperature or humidity is high.
- Avoid placing objects in front of the motion detector that may affect illuminating performance.
- Avoid installing the unit near air conditioners, central heaters, or outdoor area without water/weatherproof protection.
- As with a typical DIY or replacement light project for custom-made considerations visit your local hardware store or consult experienced electric technician for assistance on your specific mounting accessories and installation needs. User and Installer have to consider application site's environmental condition and specific lighting purpose to decide best mounting and installation arrangement.
- All installation procedures must follow their local safety standards and building, electric regulations.
- **The manufacturer and seller does not undertake any responsibility for any losses caused by improper operation and installation.**

**Specifications**

AC Power source: 110-130V/AC 50/60Hz  
 60 SMD-LED Load: 12W (Max 80W lamp)  
 LED specifications: T-2835  
 LED Color: Warm white (3000K), Pure White (5000K)  
 Lamp Brightness: 950Lm (white); 750Lm (warm)  
 Protection: Weatherproof IP65, Class2  
 Light Fixture Material: PC

Doppler sensor FREQ.: 5.8GHz (EE112WMC)  
 RF Sensing Power: <0.3mW  
 Detection range: 6feet-25feet x 360° Diameter@6-10feet High  
 Delay Time Range Setting: 10sec to 12min  
 Ambient Light Level Setting: 50lux (darkness) or 2000lux (Daylight)  
 Operating Temperature: -4F to +125F  
 Light Unit Size: 11" (L) x 5" (W) x 4" (H)  
 Weight: 1.5Lbs  
 Approvals: FCC, CE

**Important Safety Information**

Do not dispose of this plastic unit in fire. This may result in an explosion.  
 Do not expose the light to fire or intense heat as the battery may explode.  
 Do not immerse in water.  
 Never look directly into the light or shine it into another person's eyes.  
 Follow proper safety tips to prevent from falling off a ladder.  
 Consult your local construction/building safety guide if needed for installing the light fixture on a building.

**One Year Limited Warranty**

EESGI guarantees this product to be free from defects in material & workmanship for (1) year.  
 This warranty does not apply to damage from misuse or incorrect installation/ connection.  
 This warranty does not cover accessories, bulbs, batteries, high voltage accidents, alterations, unauthorized use or repair, neglect, misuse, abuse, damages or defects resulting from normal wear and tear (including chips, fading scratches, abrasions or discoloration due to usage or sun exposure), or failure to follow instructions for care and maintenance, fire, flood, and Acts of God.  
 This warranty does not include liability for incidental or consequential damages.  
 EESGI is not responsible for any damages in excess of the retail purchase price of the product under any circumstances. The consumer is responsible for the installation of, removal of, and reinstallation of the product.

**Customer service:** info@eesgi.com; www.eleding.com 1-(877)579-3889

