



Installation and Operation Instructions
for **USA only**

Model: HF-517U

Cast Iron Freestanding Stove

(EPA Approved for Washington State)



Tested &
Listed By



Portland
Oregon USA

OMNI-Test Laboratories, Inc.

Conform to UL 1482 - 2010
Report # 375-S-01-2

KINDLY SAVE THESE INSTRUCTIONS FOR FUTURE REFERENCE

Safety Notice

If this solid fuel room heater is not properly installed, a house fire may result. For your safety and to reduce the risk of fire, follow the installation instructions. Contact local building officials, fire officials or the authority having jurisdiction about restrictions and installation inspection requirements in your area, including the need to obtain a permit. Kindly save these instructions for future reference.

VERY IMPORTANT

PLEASE READ THIS ENTIRE MANUAL BEFORE YOU INSTALL AND USE YOUR NEW ROOM HEATER. FAILURE TO FOLLOW INSTRUCTIONS MAY RESULT IN PROPERTY DAMAGE, BODILY INJURY, OR EVEN DEATH! FAILURE TO READ AND FOLLOW THESE INSTRUCTIONS BEFORE YOU PROCEED MAY RESULT IN DAMAGE, VOIDING YOUR WARRANTY.

DO NOT INSTALL IN A MOBILE HOME.

DO NOT USE CHEMICALS OR FLUIDS TO START THE FIRE.

DO NOT BURN GARBAGE OR FLAMMABLE FLUIDS SUCH AS GASOLINE, NAPHTHA OR ENGINE OIL.

HOT WHILE IN OPERATION. KEEP CHILDREN, CLOTHING AND FURNITURE AWAY. CONTACT MAY CAUSE SKIN BURNS.

Please contact the Hi Flame® dealer in your area if you have any questions about your stove that are not covered in this manual.

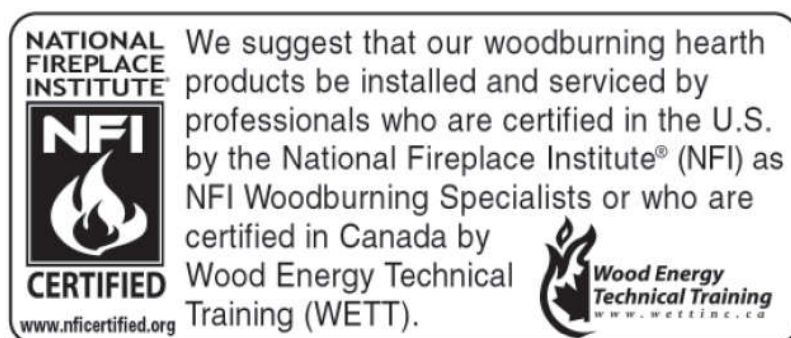

Proposition 65 Warning: Fuels used in gas, wood-burning or oil fired appliances, and the products of combustion of such fuels, contain chemicals known to the State of California to cause cancer, birth defects and other reproductive harm. California Health & Safety Code Sec. 25249.6

Introduction

Congratulations on purchasing a genuine Hi Flame® stove. When cared for properly, the high quality, finely crafted cast iron stoves and fireplace inserts will offer many years of reliable performance. This instruction manual has been developed to ensure optimum performance from the Hi Flame® stove. It's very important that you thoroughly read and understand all instructions before using your new stove or fireplace insert.

Table of Contents

	Page
VERY IMPORTANT	1
Introduction	2
Sample of Label	3
Stove Safety	4
Check Building Codes.....	5
Before Installing Your Stove	5
Adequate Air Provision	5
Installation	5
Floor Protection	6
Installation Clearances	7
Well Sealed Flue System	8
Chimney Connector	8
Chimney	9
Factory Built Chimney	10
Masonry Chimney	11
Masonry Fireplace	12
Combustible Wall Chimney Connector Pass-Throughs	13
Operating Your Stove	14
Fuel	14
First Operation of Stove	14
Air Controls	14
Refueling	15
Ash Removal and Disposal of Ashes	15
Stove Maintenance	16
Care of Fire Bricks	16
Care of Glass	17
Replacement of Glass.....	17
Replacement Parts	17
Surface Finish	17
HF-517U Part List Diagram.....	18
HF-517U Parts List	19
Trouble Shooting	20
Fire Not Burning	20
Glass Blackens	20
Smoke in Room	20
Fire Burning Too Quickly	20
Chimney fire	21
Specifications	21
Hi Flame America Warranty – Policy & Procedures	22
Warranty Exclusions and Limitations	23

Sample of Label

Tested & Listed By **O-TL** Portland Oregon USA
 OMT-Test Laboratories, Inc.
 375-S-01-2
 Tested to UL 1482-2010
 Certified for U.S.A.

LISTED SOLID FUEL FIREPLACE STOVE OR ROOM HEATER

Model: HF-517U



CONTACT LOCAL BUILDING OR FIRE OFFICIALS ABOUT RESTRICTIONS AND INSTALLATION INSPECTION IN YOUR AREA
 DO NOT USE GRATE OR ELEVATE FIRE—BUILD WOOD FIRE DIRECTLY ON HEARTH
 OPERATE ONLY WITH DOORS CLOSED

Serial No.

PREVENT HOUSE FIRES:

Install and use only in accordance with Henan Hi-Flame's installation and operation instructions. Refer to manufacturer's instructions and local codes for precautions required for passing chimney through a combustible wall or ceiling. **FOR USE WITH SOLID WOOD FUEL ONLY—DO NOT USE OTHER FUELS.** Flue connector pipe must be 6" diameter minimum 24 MSG black or 26 blue steel. **DO NOT CONNECT THIS STOVE TO A CHIMNEY FLUE SERVING ANOTHER APPLIANCE.** Chimney must be factory build UL 103HT or masonry. Inspect and clean chimney frequently. Under certain conditions of use, creosote buildup may occur rapidly. **DO NOT OVERFIRE—IF HEATER OR CHIMNEY CONNECTOR GLOWS, YOU ARE OVERFIRING.**
 NOTE: Replace glass only with 5mm ceramic glass available from your dealer.

- A—Unit to Sidewall 20"
 - B—Unit to Backwall 13"
 - C—Chimney Connector to Sidewall 28"
 - D—Chimney Connector to Backwall 15.5"
 - E—Unit to Adjacent Wall 7"
 - F—Chimney Connector to Adjacent Wall 15"
- See manual for additional installation configurations.

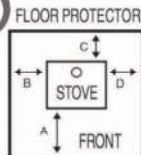
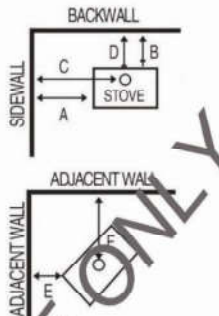

- A = 16" minimum
- B = 8" minimum
- C = 8" minimum
- D = 8" minimum

Floor protector must extend beneath the stove and 8" to the rear. It must extend 8" to the sides and 16" to the front of the fuel loading door.



CAUTION:

HOT WHILE IN OPERATING DO NOT TOUCH, KEEP CHILDREN, CLOTHING AND FURNITURE AWAY. CONTACT MAY CAUSE SKIN BURNS. SEE NAME-PLATE AND INSTRUCTIONS

U.S. ENVIRONMENTAL PROTECTION AGENCY
 Certified to comply with July 1990 particulate emission standards.
 Date of Manufacture
 Jan Feb Mar Apr May Jun Jul Aug Sep Oct Nov Dec
 2011 2012 2013

Manufactured by:
 Henan Hi-Flame Metal Co., Ltd
 Yugang Avenue
 Airport District
 Zhengzhou 451163, Henan
 China

Stove Safety

When properly maintained and operated your stove should give you many years of service. However, there are important safety aspects of these products that you need to be aware of when operating a wood stove.

1. Hi Flame recommends that you have your new stove installed by a professional installer of solid fuel burning appliances.
2. **If this room heater is not properly installed, a house fire may result. To reduce the risk of fire, follow the installation instructions. Failure to follow these instructions may result in property damage, bodily injury, or even death!**
3. **Avoid creating a low pressure condition in the room where the stove is operating. Operating an exhaust fan or a clothes dryer could create a low pressure area, causing poisonous gases to come out of the stove into the room.**
4. Only use solid wood fuel. DO NOT USE CHEMICALS TO START THE FIRE. Never use gasoline, gasoline-type lantern fuel, kerosene, charcoal, lighter fluid, naphtha, engine oil, or similar liquids to start or 'freshen up' a fire in this heater. Keep all such liquids well away from the stove while it is in use. Do not burn garbage in the stove.
5. The burning of wood gives off gases which can be extremely dangerous. The stove is designed that, under normal operating conditions, these gases pass up the flue chimney system and cannot escape into your home, however it is important that your flue system is properly installed and that you check all joints regularly to ensure that there are no cracks or gaps. Check the door sealing rope and replace when damaged. We recommend a smoke alarm be fitted in rooms where stoves are installed. Do not use stove in a room where negative pressure conditions may occur such as through the use of extraction fans, unless an adequate air supply into the room is ensured, as this may draw air through the stove and cause products of combustion to escape into the room.
6. Creosote and soot may accumulate in your flue pipe and chimney. This may ignite, causing a chimney fire. **If you suspect a chimney fire, evacuate people from the building, close down the air controls on the stove and call the Fire Department.** To prevent accumulation of soot or creosote, check flue and chimney regularly and clean as necessary. Good burning, hot stoves will generally cause a lot less build-up than slow burning stoves. Likewise, dry wood will cause less build-up than wet wood. We recommend a fire extinguisher be available where stoves are in operation. In the event of a chimney fire, do not re-light the stove until it and the flue chimney system have been thoroughly checked by fire officials and repaired as necessary.
7. Stoves get extremely hot and should not be touched when lit. When young children are in the area, we recommend the use of a suitable fire guard around the stove. Always wear protective gloves when reloading the stove.
8. **Never over-fire your stove.** If external parts of your stove are glowing red, then the stove is over-firing and your draft settings should be reduced. Never use a fan to supply air to the stove or to extract air from it.
9. All users of the stove should be aware of the contents of this manual. Please leave the manual where it is accessible to stove users and do not allow anyone to use the stove that is unfamiliar with its correct operation.
10. Never use the stove if any parts are missing or damaged. Only use genuine parts as replacements. Never modify your stove.
11. **DO NOT INSTALL IN A MOBILE HOME.**

We hope you have many years of warmth and comfort from your stove but please do so safely.

Check Building Codes

- When installing, operating and maintaining your stove, follow the guidelines presented in these instructions, and make them available to anyone using or servicing the stove.
- **Your city, town, county or province may require a building permit to install a solid fuel burning appliance.**
- In the U.S., the National Fire Protection Association's Code, NFPA 211, Standards for Chimneys, Fireplaces, Vents and Solid Fuel Burning Appliances, or similar regulations, may apply to the installation of a solid fuel burning appliance in your area.
- **Always consult your local building inspector or authority having jurisdiction to determine what regulations apply in your area.**

Before installing your stove

You need to consider the following to ensure the safe operation of your stove:

- Provision of adequate air to support efficient combustion of the fuel
- A well-sealed flue/chimney system, herein after referred to as the "flue system"
- The protection of combustible materials in proximity to the stove

Adequate air provision

It is essential for the safe and efficient use of your stove that you provide an adequate air supply when lighting a fire, especially if there are extraction units such as cooker hoods or clothes dryers in the vicinity. Crack the door open a little and allow air to enter. Once the air in the stove and the flue stabilize, you can then close the door of the stove. Failure to do so will mean that fuel is burned inefficiently, causing smoke and blackening the glass and may also cause smoke to come back into the room.

Installation

Unpacking and preparing your stove for installation:

1. Remove your stove from the outer packaging and place on floor. Please inspect stove and check that it is not damaged in any way. Never attempt to use a stove that has been damaged.
2. Remove and check the following contents (spare parts found in ash pan):
 - Instruction manual
 - Legs & leg nuts (M8) – 4 pcs each
 - Wooden handle & handle holder – 1 pc each
 - Flue spigot – 1 pc
 - Spare glass clips (2)
 - Spare screws (M5 x 8mm) for glass clips (2)
 - Ash pan & shovel - 1 pc each
 - Operating tool - 1 pc
 - M8 Nuts & washers – 2 sets
 - Insulated mitten
3. Gently lay the stove on its back. Remove screws from four corners of base and fit one of the legs to each corner of the stove. Tighten bolt to ensure leg is secure to base of stove. When complete, gently stand the stove upright.
4. Move the stove into position. **Do not drag the stove** as this may damage the legs and/or screws of base.

In the unlikely event that something is missing, please contact your dealer immediately.

The floor protection

If the stove is to be installed on a combustible floor, it must be placed on a non-combustible hearth pad. In the USA, the floor protector must extend 8" beyond each side of the fuel loading door and 16" to the front (18" to the front in Canada). (See fig. 4)

Floor protection under the stove must be a UL 1618 Type 1 Ember Protector composed of non-combustible material for protection from radiant heat, sparks and embers.

Individual sections of floor protection must be mortared together to prevent sparks from falling through to combustible materials. Any carpeting must be removed from under the floor protection.

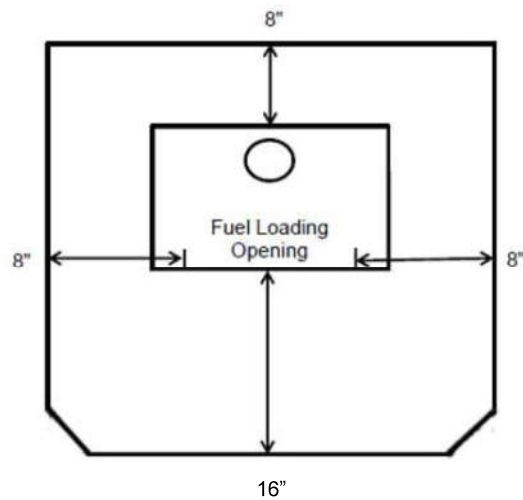
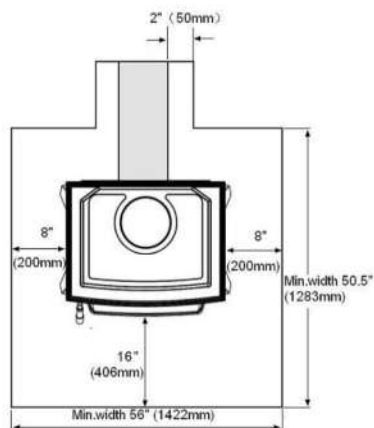

Fig. 4

In a rear vent installation the floor protection must also extend under the stovepipe and a minimum of 2" (50mm) beyond either side of the pipe.



Installation Clearances

It is extremely important that you respect required installation distances and that you respect local installation regulations. This is for your safety. The manufacturer is not responsible for the product if it is not installed following these recommendations. These clearances may only be reduced by means approved by the regulatory authority.

One necessary precaution when installing a wood stove is to leave sufficient space between the stove (top, sides, back, front, and under stove pipes) and any other material that can catch fire. The clearance from the top of the unit to the ceiling is 75" (1,905 mm). All other clearances are found in the table below.

A combustible surface is anything that can burn (i.e. sheet rock, wall paper, wood, fabrics, etc.) These surfaces are not limited to those that are visible and also include materials that are behind non-combustible materials. If you are not sure of the combustible nature of a material, consult your local fire officials.

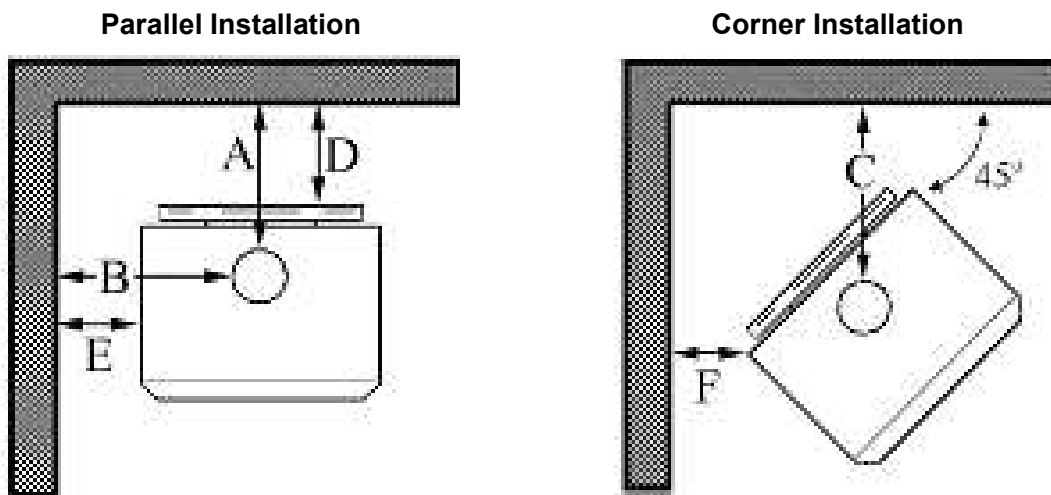

	HF-517U Single wall connector pipe
A – Chimney Connector to back wall	15.5" (394mm)
B – Chimney Connector to sidewall	28" (711mm)
C – Chimney Connector to corner wall	15" (381mm)
D – Unit to back wall	13" (330mm)
E – Unit to sidewall	20" (508mm)
F – Unit to corner wall	7" (178mm)

Well sealed flue system

Only materials and items approved for solid fuel stoves should be used for your stove. Under no circumstances should you use aluminum or galvanized steel pipes for your stove flue.

Always fit pipes with the narrow side down. This will allow any creosote to run down the inside of the pipe and not to come out and cause an unsightly mess and possible fire hazard. All joints in the flue system should be sealed with fire cement and/or an appropriate fire resistant rope or gasket.

Pipe bends should be kept to a minimum and we do not recommend using more than 2 bends on any installation. Flues must not pass through ceilings, floors, attics, roofs, or combustible walls without adequate and approved insulation being provided to protect combustible materials.

The chimney and flue provide a means of taking combusted fuel from the stove, as well as a draft to enable the stove to work. It is essential that the flue system is kept in good condition and there are no breaks or cracks allowing contact with any other combustible materials of the house. It is also essential that the flue system is kept clean and seals are maintained to ensure the draft is not lost.

The open end of the flue system must be above the height of the apex of the building and any other obstructions, such as trees, which are within 10 feet (3m) of the flue system. Failure to do this will affect the efficiency of the stove and may cause down drafts, which will mean dangerous products of combustion are emitted into room.

Under no circumstances should the flue pipe be less than 6" (152.4mm) internal diameter.

Chimney connector

The chimney connector is a single walled pipe used to connect the stove to the chimney. For use with the appliance, the chimney connector **MUST** be 6" in diameter, with a minimum thickness of 24 gauge black steel or 26 gauge blue steel.

Aluminum and galvanized steel pipe is not acceptable for use with the appliance. These materials cannot withstand the extreme temperatures of a wood fire and **can give off toxic fumes when heated.**

Do not use the connector pipe as a chimney.

Each chimney connector or stovepipe section must be installed to the stove flue collar and to each other with the male (crimped) end toward the stove. See fig 5.

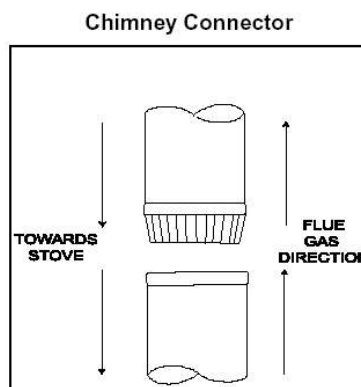

Fig. 5

This prevents any amount of condensed or liquid creosote from running down the outside of the pipe or the stovetop. All joints, including the flue collar connection, must be secured with three sheet metal screws to ensure that the sections do not separate.

For the best performance, the chimney connector should be as short and direct as possible, with no more than two 90° elbows. The maximum horizontal run is 36" (914mm) and a recommended total length of stovepipe should not exceed 10 feet (3 m). Always slope horizontal runs upward ¼" (6.35 mm) per foot toward the chimney.

No part of the chimney connector may pass through an attic or roof space, closet or other concealed space, or through a floor or ceiling. All sections of the chimney connectors must be accessible for cleaning. Where passage through a wall or partition of combustible construction is desired, the installation must conform to National Fire Protection Association (NFPA) 211, and is also addressed in this manual.

Chimney

- DO NOT CONNECT THIS UNIT TO A CHIMNEY FLUE SERVING ANOTHER APPLIANCE.
- DO NOT CONNECT TO ANY AIR DISTRIBUTION DUCT OR SYSTEM.

This room heater must be connected to a 6" factory-built UL 103 HT chimney or a code-approved masonry chimney with a flue liner.

Chimney Height

A masonry chimney or a listed factory-built chimney must be the required height above the roof and any other nearby obstructions. The chimney must be at least 3 feet (91 cm) higher than the highest point where it passes through the roof and at least 2 feet (61 cm) higher than the highest part of the roof or structure that is within 10 feet (305 cm) of the chimney, measured horizontally.

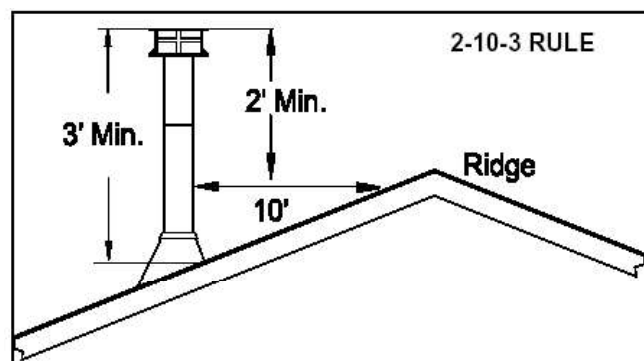

Factory-Built Chimney

When a metal prefabricated chimney is used, the manufacturer's installation instructions must be followed. You must also purchase (from the same manufacturer) and install the ceiling support package or wall pass-through and "T" section package, firestops (where needed), insulation shield, roof flashing, chimney cap, etc. Maintain proper clearance to the structure as recommended by the manufacturer. The chimney must be the required height above the roof or other obstructions for safety and proper draft operation.

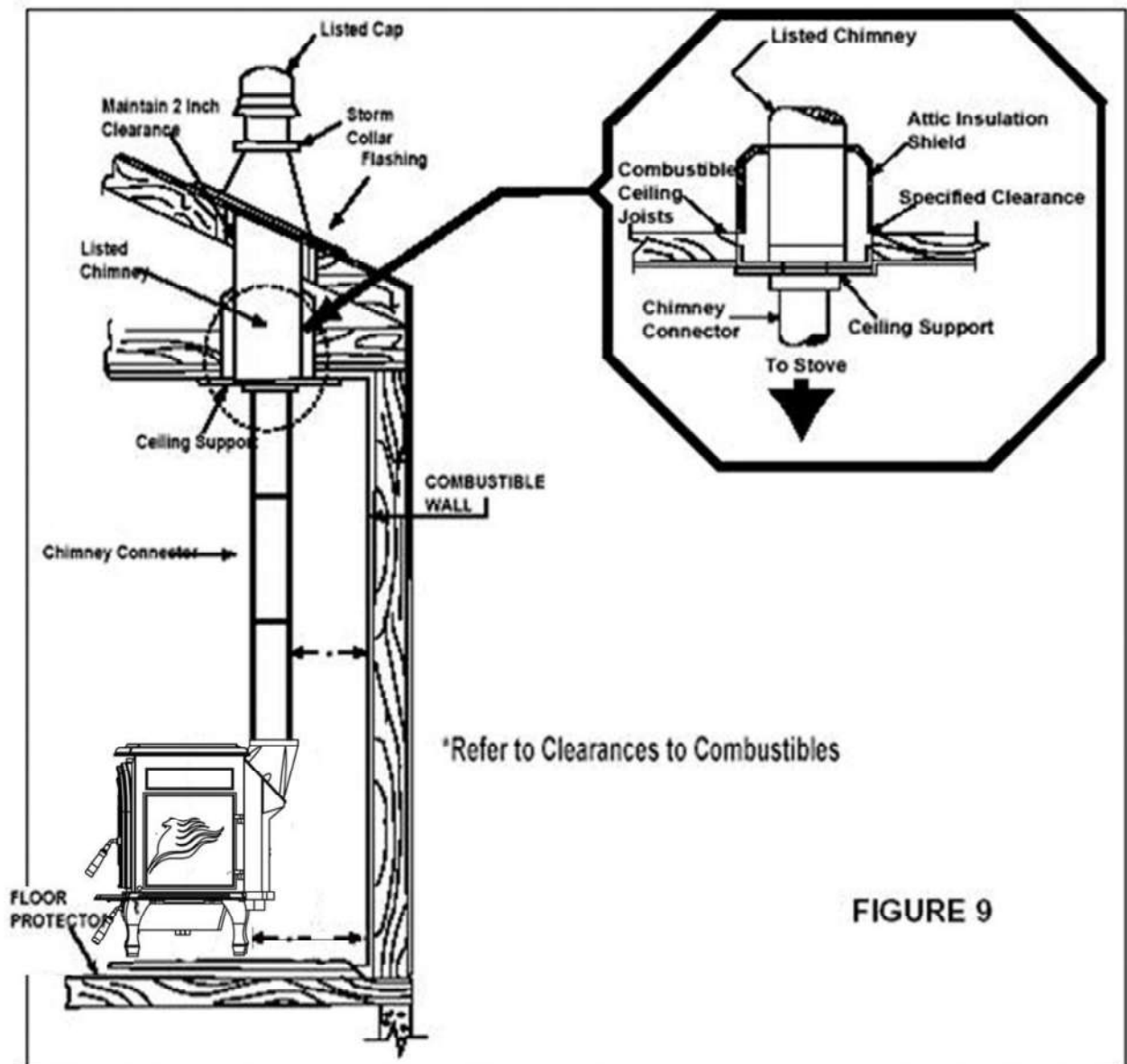
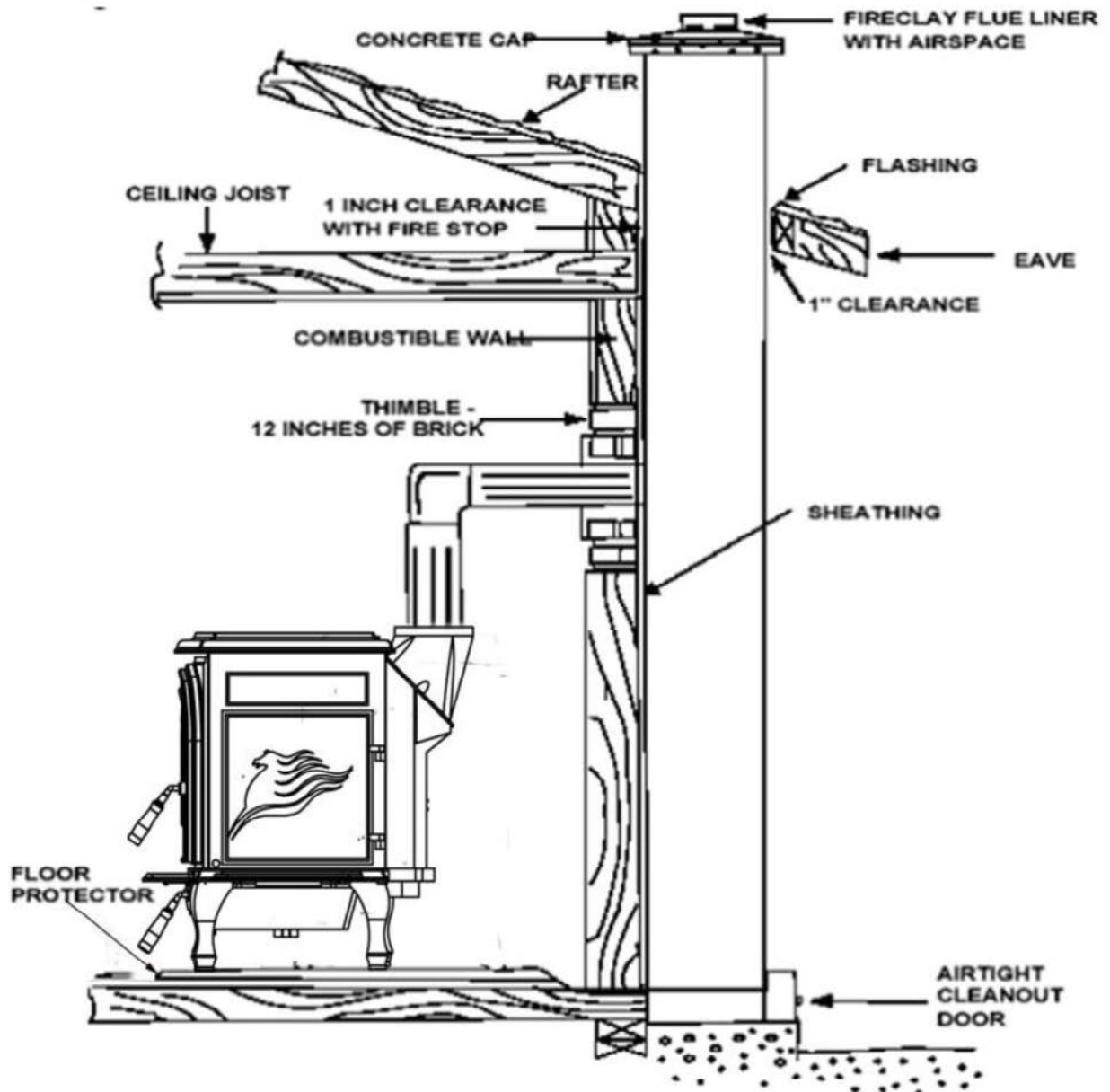

FIGURE 9

Masonry Chimney

Ensure that a masonry chimney meets the minimum standards of the National Fire Protection Association (NFPA) by having it inspected by a professional. Make sure there are no cracks, loose mortar or other signs of deterioration and blockage. Have the chimney cleaned before the stove is installed and operated. When connecting the stove through a combustible wall to a masonry chimney, special methods are needed.



Masonry Fireplace

There are listed kits available to connect a stove to a masonry fireplace. The kit is an adapter that is installed at the location of the fireplace damper. The existing damper may have to be removed to allow installation.

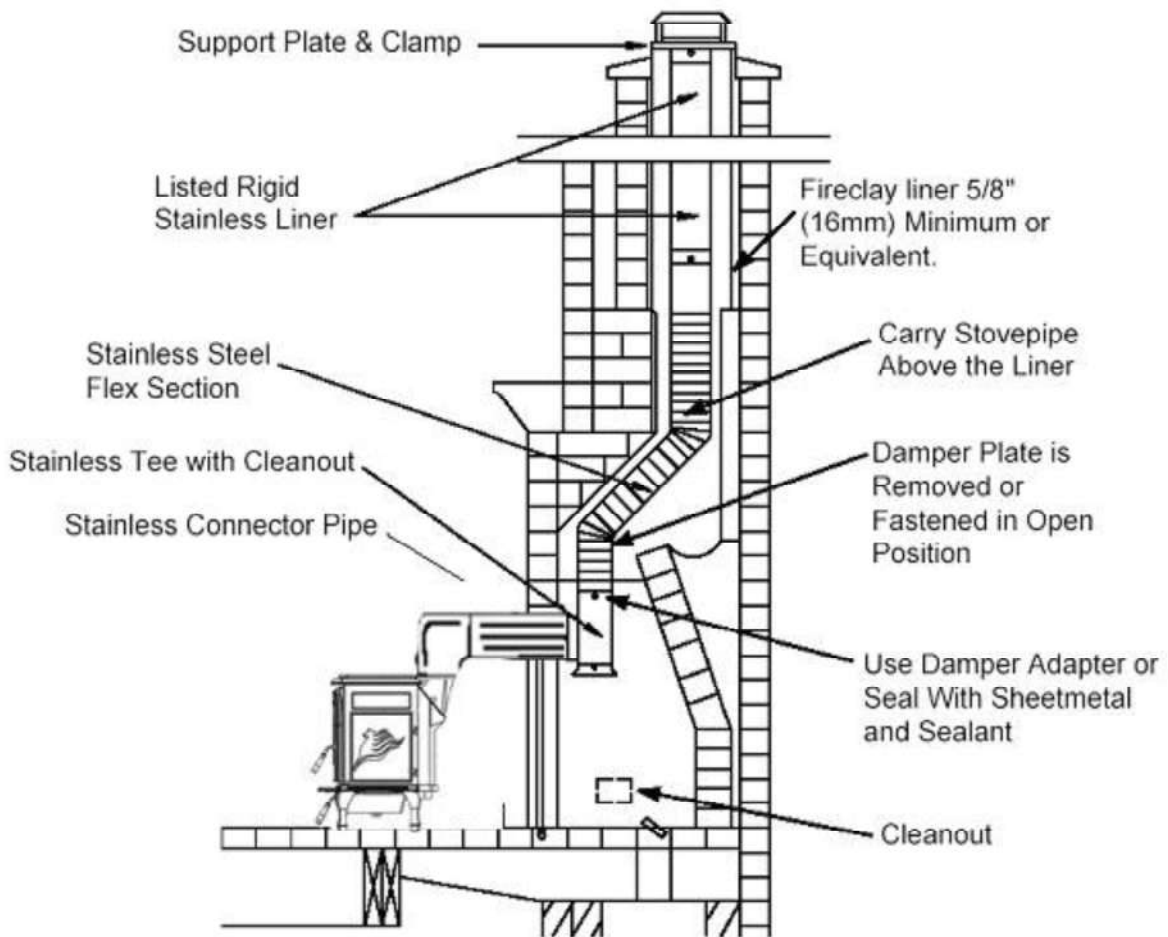

Combustible Wall Chimney Connector Pass-Throughs

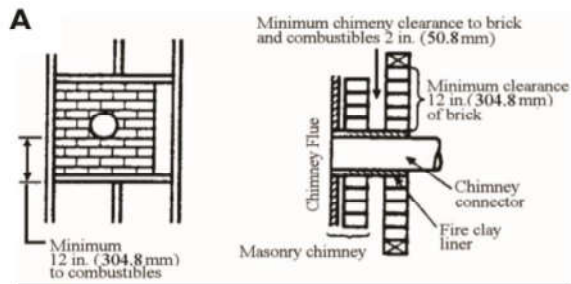

Method A. 12" Clearance to Combustible Wall

Member: Using a minimum thickness 3.5" brick and a 5/8" minimum wall thickness clay liner, construct a wall pass-through. The clay liner must conform to ASTM C315 (Standard Specification for Clay Fire Linings) or its equivalent. Keep a minimum of 12" of brick masonry between the clay liner and wall combustibles. The clay liner shall run from the brick masonry outer surface to the inner surface of the chimney flue liner but not past the inner surface. Firmly grout or cement the clay liner in place to the chimney flue liner.

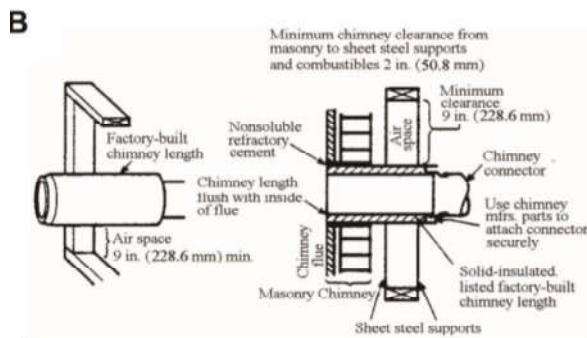

Method B. 9" Clearance to Combustible Wall Member:

Using a 6" inside diameter, listed, factory-built Solid-Pak chimney section with insulation of 1" or more, build a wall pass-through with a minimum 9" air space between the outer wall of the chimney length and wall combustibles. Use sheet metal supports fastened securely to wall surfaces on all sides, to maintain the 9" air space. When fastening supports to chimney length, do not penetrate the chimney liner (the inside wall of the Solid-Pak chimney). The inner end of the Solid-Pak chimney section shall be flush with the inside of the masonry chimney flue, and sealed with a non-water soluble refractory cement. Use this cement to also seal to the brick masonry penetration.

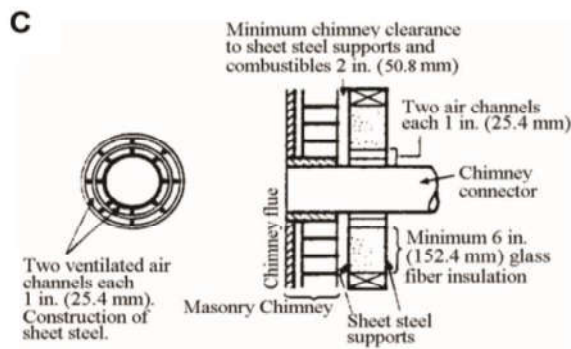

Method C. 6" Clearance to Combustible Wall

Member: Starting with a minimum 24 gage (.024"), 6" metal chimney connector, and a minimum 24 gage ventilated wall thimble which has two air channels of 1" each, construct a wall pass-through. There shall be a minimum 6" separation area containing fiberglass insulation, from the outer surface of the wall thimble to wall combustibles. Support the wall thimble, and cover its opening with a 24-gage minimum sheet metal support. Maintain the 6" space. There should also be a support sized to fit and hold the metal chimney connector. See that the supports are fastened securely to wall surfaces on all sides. Make sure fasteners used to secure the metal chimney connector do not penetrate chimney flue liner.

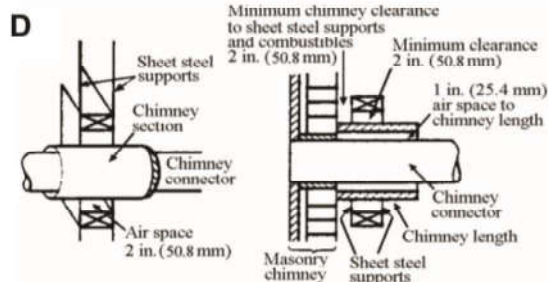

Method D. 2" Clearance to Combustible Wall

Member: Start with a solid-pak listed factory built chimney section at least 12" long, with insulation of 1" or more, and an inside diameter of 8" (2 inches larger than the 6" chimney connector). Use this as a pass-through for a minimum 24-gage single wall steel chimney connector. Keep solid-pak section concentric with and spaced 1" off the chimney connector by way of sheet metal support plates at both ends of chimney section. Cover opening with and support chimney section on both sides with 24 gage minimum sheet metal supports. See that the supports are fastened securely to wall surfaces on all sides. Make sure fasteners used to secure chimney section shall not penetrate chimney flue liner.

NOTES:

1. Connectors to a masonry chimney, excepting method B, shall extend in one continuous section through the wall pass-through system and the chimney wall, to but not past the inner flue liner face.
2. A chimney connector shall not pass through an attic or roof space, closet or similar concealed space, or a floor, or ceiling.

Operating Your Stove

- Do not use a grate, andiron or other fuel support method. Build fire directly on the hearth.
- Only open door to fuel/refuel the stove. Excess air can cause the stove to over fire. Do not over fire. If chimney or stove is glowing red, you are over firing.
- Do not build the fire too close to the glass. Do not abuse the glass doors. Do not strike or slam the door shut.

Fuel

Your stove is designed to burn solid wood fuel only; **it is not designed to burn:**

- Paper or cardboard, other than small amounts used to light stove
- Treated or painted wood
- Synthetic fuel or logs that are not approved for solid fuel stoves
- Household rubbish
- Liquid fuels
- Plastics

Burning these or other products for which the stove was not designed may damage the stove and cause a fire hazard or release toxic fumes.

Fuel should be stored in a dry place; wood should be dried for at least 1 year. Do not store fuel within the installation clearances or within the space required for refueling and ash removal. Wet wood may cause serious creosote, which may damage your flue system and even your stove. Therefore, the use of wet wood is strongly discouraged.

First operation of stove

You should begin using your stove by lighting small fires which get progressively bigger. We recommend a series of about five small fires before you put the stove into full service. Allow the stove to fully cool between each of these fires. There may be some smell and a small amount of smoke from the stove during the initial operations. This is perfectly normal and is merely the curing of the stove paint. Opening a window or door to provide additional ventilation will help alleviate this.

Air controls

Your stove needs air to burn the fuel. This air is supplied through an opening along the inside front of the stove, above the top of the window (Primary) and the small holes on the two-tiered deflecting plate on the top inside of the stove. (Secondary). The secondary air supply is fed from a large air channel at the back of the stove.

Primary air, as the name suggests, is used for the initial burning of the fuel and also to keep the stove glass clean. Secondary air is used for secondary combustion, which makes the stove more efficient and reduces the emissions. Wood burns better with the air over the fire bed and when burning a lot of wood, you should regulate the primary air supply.

The setting of the primary air control very much depends on draft and local conditions and after a few fires, you should have a good idea of the best settings for your stove. The air controls should be fully opened (move air control lever all the way to the left) when lighting the fire. Once the fire is established, the controls may be adjusted as required. Reducing the air intake will

cause the stove to burn slower. This may cause some blackening of the stove glass, but this should burn off once the stove is burning brightly again.

Refueling

Before refueling your stove, turn the air supply on high for a few moments until there is a good fire within the stove. This will ensure there is no build-up of harmful gases in the stove when the door is opened and will also get the new fuel burning quickly and not allow it to kill the fire.

To reload the stove, open the door and feed the fuel in slowly, using tongs. Do not overfill the stove. It is always better to put in small loads often rather than big fills less frequently. Close the door gently after stove is reloaded.

You should always wear protective gloves and use tongs when tending a hot stove.

Ash removal

When ash has built up in the ash pan, it should be emptied. Failure to do this will cause ash to build up around the grate and may cause your grate to warp or burn out. It is especially important when burning fuel with high ash content, that you keep your grate clear and your ash pan emptied regularly, so as not to damage your grate. Clear the grate with a poker on a regular basis.

To remove the ash, open the stove door and use the operating tool provided to lift the ash pan out of the stove. If possible, this should be done before lighting the stove, when the ash is cold. Even if the ash appears to be cold, it should be placed in a non-combustible container as there may be hot ash in the center of the pile. You should always wear protective gloves when removing ash from the stove.



This stove is not designed to operate with the door open. Always close the stove door when you have taken out the ash tray and leave closed while disposing of the ash. Only reopen to put ash pan back into the stove and close immediately afterwards.

Disposal of ashes

Ashes should be placed in a steel container with a tight fitting lid and moved outdoors immediately. The closed container of ashes should be placed on a non-combustible floor or on the ground, well away from all combustible materials, pending final disposal. If the ashes are disposed of by burial in soil or otherwise locally dispersed, they should be retained in the closed container until all cinders have thoroughly cooled. Do not place any other waste in the container.

Stove Maintenance

Check stove regularly

Creosote: Formation and Need for Removal

When wood is burned slowly, it produces tar and other organic vapors, which combine with expelled moisture to form creosote. The creosote vapors condense in the relatively cool chimney flue of a slow-burning fire. If a significant layer of creosote has accumulated (3 mm or more), it should be removed to reduce the risk of a chimney fire. **The chimney and chimney connector should be inspected at least once every two months during the heating season** to determine if a creosote buildup has occurred.

Initially, we recommend you check your flue system at least once per month. After the first few months you will notice a pattern of soot and creosote build-up and you can then determine an inspection interval for checking soot and creosote build-up that is suitable for your stove installation.

Other checks, as listed below, should be carried out at least twice per year. If you notice anything wrong, at any time, it should be repaired immediately. Never use a stove that is in any way damaged or has a damaged flue.

1. Check your flue system for build-up of soot or creosote and for signs of damage to joints. To check flue outlet, remove top of baffle by lifting and pulling out at end. Use a flashlight to check flue outlet. Clean and repair as necessary. Always replace top baffle before relighting stove.
2. Check that glass is not cracked or chipped and that sealing rope is in good condition. Replace as necessary.
3. When the room is dark, use a strong flashlight to check the sealing of the stove at the edge and corners for leaks. Any leaks or cracks found should be repaired with fire cement or damaged parts should be replaced with genuine spare parts.
4. Check that stove door is tight and sealed well when closed. Place a strip of paper into the stove and close the door. Try to pull out paper. You should feel some resistance to your pull. Check several points around the door. If it pulls out too easily, replace the rope and seal in place with a suitable high temperature sealant.

Care of fire bricks

Your stove comes with Fire Bricks lining the fire box. They serve as insulation as well as protection to the cast iron or steel fire box. The fire bricks are quite delicate as compared to the rest of your stove, so please keep this in mind when loading logs into the firebox. They will crack and chip if not cared for properly. Fire bricks expand and become brittle when heated. Use caution when cleaning the firebox and around the ash grate. **Do not try to pry off fire bricks while cleaning as they will break. Damage caused by the mishandling of fire bricks will not be covered under warranty.**

Care of glass

At times, especially when the air control is turned to a low setting or when damp wood is used, the stove glass will blacken. This is caused by fuel that is not completely burned, but the build-up on the inside of the glass will normally burn off when a good hot fire is established in the stove.

There may be times, however, when you need to clean the glass. To do this, use a soft cloth and a non-abrasive glass cleaner. Only ever clean the glass when the stove is cold. When loading fuel into the stove, always make sure it is not protruding out through the door opening, as this may break the glass when you close the door. This is especially relevant when loading logs. Always close the door gently.

Do not operate with broken or cracked glass. If the glass does crack when the stove is lit, let the fire die out. Do not open the door until the stove has fully cooled. Replace the glass only with the specified replacement part before re-using the stove.

Replacement of glass

1. Remove the door from the stove and place on a flat surface.
2. Carefully remove all of the glass clips from the inside of the door.
3. Gently remove the glass panel and gasket.
4. Using a wire brush, remove all remaining debris from the glass area.
5. Apply a small bead of gasket/stove cement to the new gasket. Do not overlap the ends of the gasket rope.
6. Center the new glass panel over the gasket and reinstall the glass clips.***
7. It may be necessary to retighten the glass clips after the stove has been burned and the gasket has been seated.

*****Important: It is extremely important to tighten the glass clips slowly and in an alternating pattern. Always wear protective gloves when you handle glass with sharp edges.**

Replacement Parts

Always use genuine replacement parts.

Ask retailer for compatible replacement parts. Only ever make replacements when the stove is cold. Replace glass only with 5 mm ceramic glass, available from your dealer.

Surface finish

The stove should only be cleaned using a damp cloth. Some cleaning products may leave stains on the stove surface. Never use abrasive cloths as these may scratch the surface. Painted stoves can be re-painted by using a good quality, high temperature stove paint. When re-painting, make sure there is plenty of ventilation and follow the manufacturer's instructions. Allow the paint to fully dry before lighting the stove and allow extra ventilation for the first couple of fires as some fumes may emit from the stove as the paint cures.

HF-517U Parts List

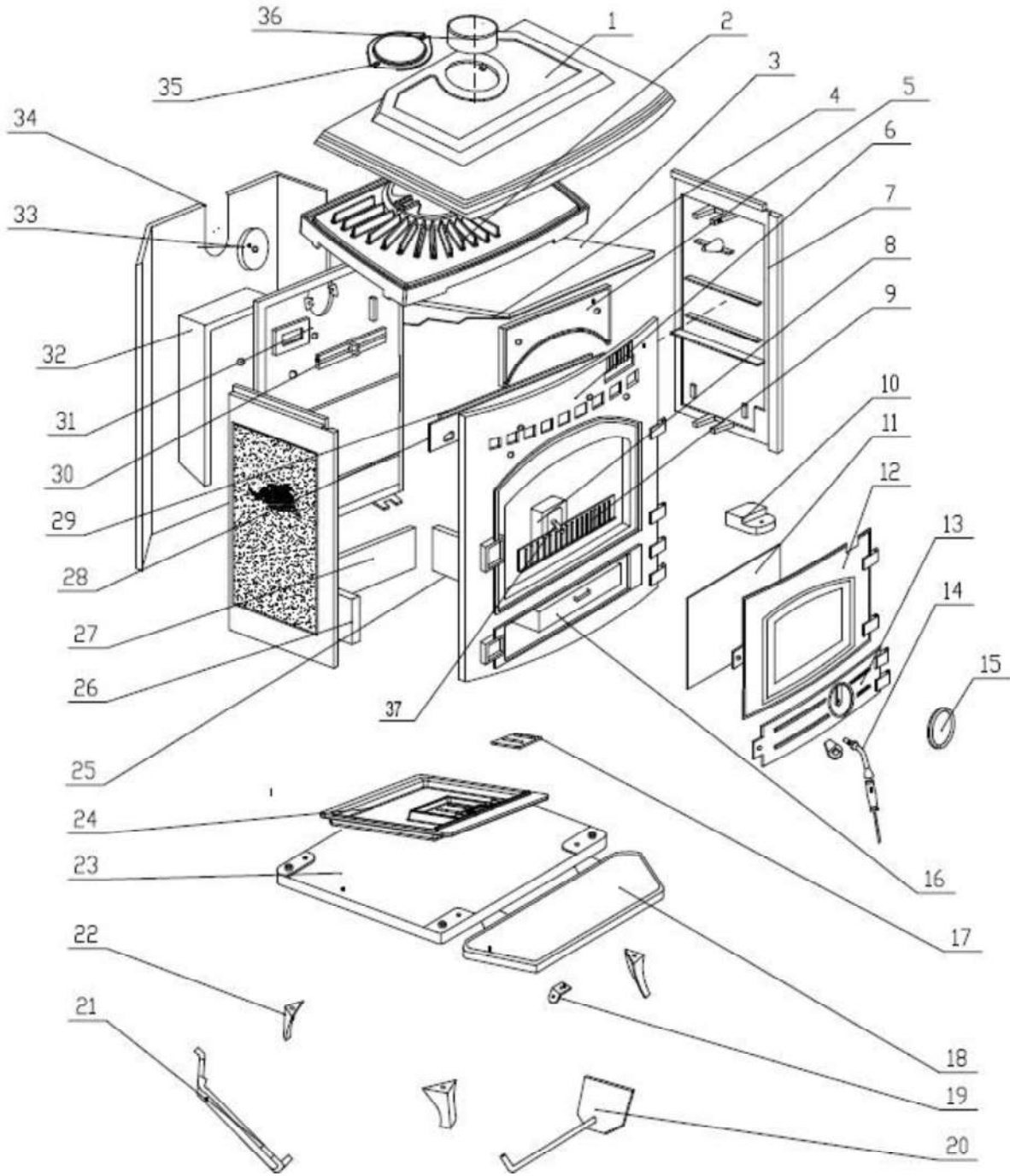

HF-517U Parts List

1. Hob
2. Inner Top
3. Bearing plate for secondary air deflecting plate
4. Secondary air deflecting plate (tiered)
5. Air wash deflecting plate
6. Front
7. Side panel – Left & Right
8. Front air flow channel
9. Fire fence
10. Air wash control lever
11. Glass
12. Front loading door
13. Ash door
14. Stainless steel handle
15. Ornamental spin valve
16. Ash pan
17. Grate
18. Ash lip
19. Handle holder
20. Ash shovel
21. Operating tool
22. Legs (4)
23. Base
24. Grate frame
25. Right, side fire brick
26. Left, side fire brick
27. Back side fire brick
28. Air wash slider
29. Air wash slider holding plate
30. Rear vent locking piece
31. Back panel
32. Back air flow channel
33. Back flue cover plate
34. Back heat shield
35. Flue cover plate
36. Flue collar
37. Front air-intake tube

Trouble Shooting

Fire not burning

A stove not burning is generally caused by either a shortage of air and/or incorrect or damp fuel. If fuel is not the problem check:

- That the air controls are opened.
- That there is no blockage in the flue system.
- That the open end of the flue is above the height of any nearby obstructions.
- That there is a sufficient air supply into the room and that this supply is not being taken by an extractor fan.

Glass blackens

Glass usually blackens when:

- The fuel is not being burned efficiently because of starvation of air.
- Bad quality or damp fuel is being used.
- Balance between primary and secondary air is incorrect.

Try to introduce more air into the stove (move lever to the left) through the primary air control on the top right of the stove door, as this air flows down over the glass to help burn off the creosote. For optimum efficiency always use a good quality, dry wood.

Smoke in room

If the stove is properly installed it should not emit any smoke into your room. Check to see if your chimney is blocked or obstructed and that you are not getting a down draft caused by the location of the open end of the flue pipe or chimney.

If the problem persists, contact your dealer and ask him to get your chimney and stove installation checked.

Fire burning too quickly

This is usually caused by too much draft or air.

- First, try reducing the air supply to the stove by closing down your air controls (Move air control lever to far right). If this fails, then you may have damage to the sealing.
- Check the condition of the door sealing rope and the joints within the stove. Refer to information listed under "Stove Maintenance-Check Stove Regularly" in this manual.

If neither of these solves the problem, you may have too much draft on your chimney and you may need to fit a damper valve into your flue system. You should not install a flue damper without consulting a specialist. Never install a damper that can completely block your flue or chimney. Contact your dealer to discuss this.

Chimney fire

Chimney fires occur when soot and creosote that have built up in the flue system ignite. If the stove is operated properly and the flue checked and cleaned regularly, then chimney fires should not occur. These fires can be very dangerous and must be avoided. Try to maintain good, hot fires in the stove whenever possible and at least once during every firing, open the air controls and allow the stove to burn on full for a short while until the entire fire bed is glowing red. Check your flue system regularly for build-up of soot and creosote and clean as necessary.

Chimney fires can be detected by sparks coming from the top of the chimney, a roaring sound coming from the area of the stove or chimney or vibration in the stove or chimney.

In the event of a chimney fire, close the air controls, evacuate the building and call the fire department. Do not relight the stove after a chimney fire until the stove and flue have been checked and any necessary repairs have been carried out.

Specifications

Model No: HF-517U

Maximum Output EPA test wood: **24,358 BTU/h**

Maximum Output Seasoned Cord Wood: **37,000 BTU/h**

Overall Efficiency: **73%**

EPA Emissions: **3.6 Grams/h**

Real Net Weight: **306lbs (±5lbs) / 139kgs (±2kgs)**

Heating Area: **1,200 Sq. Feet**

Size of Fire Box: **1.2 Cubic Feet**

Dimension (H x W x D): **28 1/8" x 22 1/4" x 19"**

714mm x 565mm x 483mm

Flue Size: **6"(150mm)**

Maximum log length: **16" (406mm)**

Olymberyl America, Inc. Warranty

Warranty Policy & Procedures

If you believe your Hi Flame® stove is defective, you should contact your nearest authorized Olymberyl America stove dealer, who will process a warranty claim. In order to qualify for warranty coverage, Olymberyl America must receive notice of a possible defect within thirty (30) days of being discovered, or reasonably could have been discovered.

Olymberyl America offers the original retail purchaser of Hi Flame Solid Fuel burning products a limited 7-year warranty. The following outlines the Olymberyl America warranty program.

This warranty applies to the original retail purchaser only. Olymberyl America warrants that this stove or fireplace insert will be free of defects in material and workmanship for a period of up to seven years from the date of purchase. Olymberyl America will ship, at no cost to the retailer, and the retailer will help you replace the parts or repair at their option, any stove or fireplace insert or part thereof found to be defective.

DESCRIPTION	Warranty Defined
Cast Iron Parts	5Years
Firebox (welding only)	5 Years
Handle Assembly	5 Years
Ash Pan	5 Years
Baffle Set	3 Years
Ceramic Glass (Thermal Breakage ONLY)	1 Year
Fire Bricks	1 Year

Customer must first submit 3 digital photos to the dealer from whom the product was purchased, along with an explanation of the problem. This will initiate a warranty claim. If a response is not received within 2 business days, please contact Olymberyl America directly email us at info@hiflame.com or juew0706@gmail.com so we may put you in contact with a customer service representative.

If any damage is found to be the fault of the manufacturer, the repair or replacement will be made. This warranty does not include expenses incurred from travel time or loss of service. This warranty is not transferrable and is extended only to, and is solely for the benefit of, the original retail purchaser of the stove/fireplace insert. Please keep your dated sales receipt as proof of purchase.

Exclusions and Limitations

NOTICE: This warranty is void if installation or service is performed by someone other than an authorized installer or service agency, or if installation is not in conformance with the installation and operating instructions contained in this owner's manual or local and/or national fire and building regulations. A listing of local authorized installers and service agencies can be obtained from the National Fireplace Institute at <http://www.nficertified.org>.

This warranty does not cover the following:

1. Damage due to incorrect installations not in conformance with the manufacturer's installation instructions or local and national regulations. It is the responsibility of the installer to ensure that the unit is installed and operating correctly at the time of installation.
2. Damage caused by over-firing, which causes any part of the appliance to glow red, as defined in the operation manual. Over-firing can be identified by warped plates, rust colored cast iron, paint pigment that has turned dusty white, or bubbling, cracking and discoloration of the enamel finish.
3. Damage caused by unauthorized modification, use, or repair.
4. Travel time or any other related expenses are not covered under warranty.
5. At no time will Olymberyl America be liable for any consequential damage which exceeds the purchase price of the unit. All warranties, implied warranties of merchantability or other, are limited in duration to the length of this written warranty. No other warranty, including oral, is enforceable.

Please contact a Olymberyl America® dealer in your area if you have any questions about your stove that are not covered in this manual.

For further information, please contact North America Corporate Office:

Olymberyl America, Inc.
1603 Capitol Ave.,
Suite 314-900 Cheyenne,
WY82001
Email: info@hiflame.com
juew0706@gmail.com
(9am - 5pm eastern, M-F)