









Thank you for purchasing this quality product. Be sure to unpack carefully looking for small parts which may have come loose during shipment.
Read all instruction and study the drawing carefully before starting the assembly process.

HARDWARE LIST					PARTS LIST			
NO	DRAWING	DESCRIPTION	SIZE	Q' TY	NO	DRAWING	DESCRIPTION	Q' TY
A		Hexagonal Bolt	ϕ5/16"*1 3/4"	14PCS	1		Panel Headboard	1PC
B		Spring Washer	ϕ5/16"	14PCS	2		Headboard Leg (Left & Right)	2PCS
C		Flat Washer	ϕ5/16"	14PCS	3		KD Leg (Left & Right)	2PCS
D		Open Wrench	12*90mm	1PC	4		Stretcher	1PC

STEP 1 : Attach stretcher (4) to Headboard leg (2) using Hexagonal Bolt (A) Spring washer (B), Flat Washer (C) and tighten them by using a Phillips head screwdriver.

STEP 2 : Attach K D leg (3) to Headboard leg (2) and Panel Headboard (1) using Hexagonal Bolt (A) Spring washer (B), Flat Washer (C) and tighten them by using a Phillips head screwdriver.

STEP 3 : K D leg(3) can be removed.

Attach Panel Headboard (1) using Hexagonal Bolt (A) Spring washer (B), Flat Washer (C) and tighten them by using a Phillips head screwdriver.

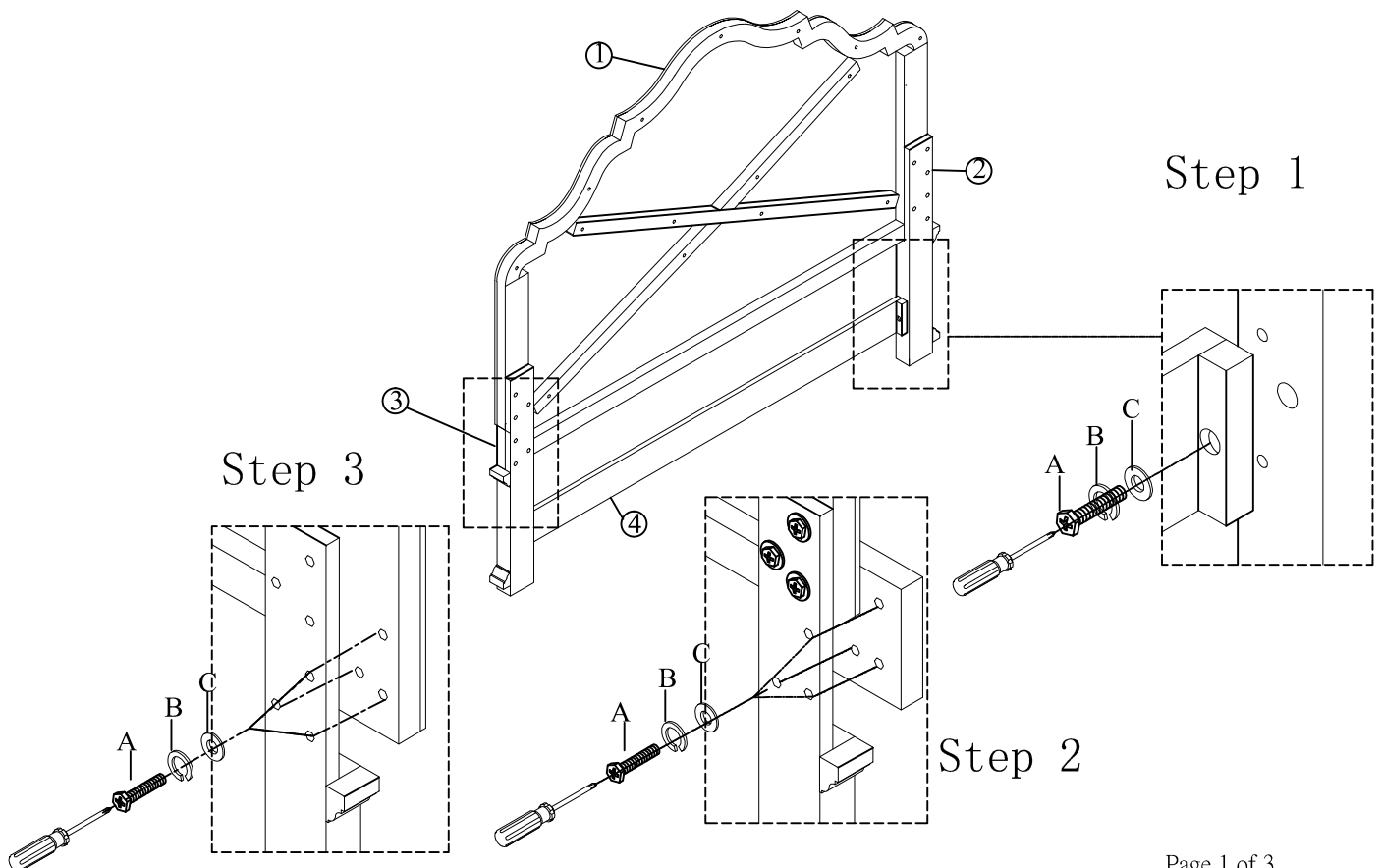











ASSEMBLY INSTRUCTION

ITEM: 5930-90367-WH PANEL HEADBOARD 6/0-6/6
 5930-90368-WH PANEL FOOTBOARD 6/0-6/6
 5930-90353-WH SIDE RAIL 5/0-6/6 RAILS

Thank you for purchasing this quality product. Be sure to unpack carefully looking for small parts which may have come loose during shipment.

Read all instruction and study the drawing carefully before starting the assembly process.

HARDWARE LIST					PARTS LIST			
NO	DRAWING	DESCRIPTION	SIZE	Q' TY	NO	DRAWING	DESCRIPTION	Q' TY
E		Threaded rod	ø5/16"*3-1/2"	8PCS	5		Panel Headboard	1PC
F		Curved Washer	ø5/16"	8PCS	6		Rails	2PCS
G		Nut	ø5/16"	8PCS	7		Panel Footboard	1PC
H		Open Wrench	12mm	1PC	8		Slats	5PCS
I		Screw	8*30	10PCS	9		Support leg for slat	5PCS

STEP 4 : Attach Rails (6) to panel Headboard (5) Panel Footboard (7) using Threaded rod (E) Curved Washer (F), Nut (G) and tighten them by open Wrench (H).

STEP 5 : Attach support leg (9) to slats (8)



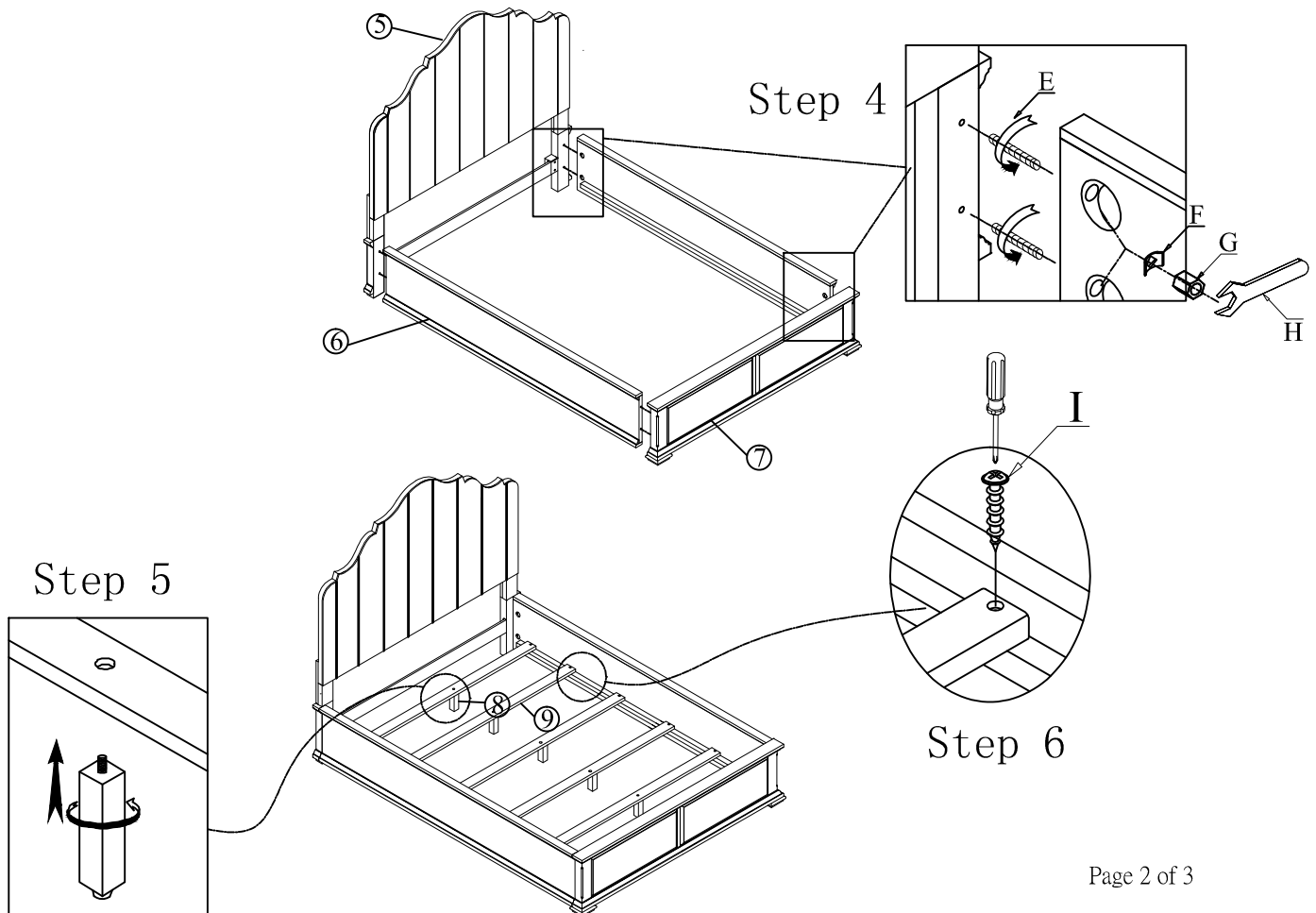







STEP 6 : Attach the slats to the rails and tighten them by using a Phillips head screwdriver.



ASSEMBLY INSTRUCTION

ITEM: 5930-90367-WH PANEL HEADBOARD 6/0-6/6
 5930-90370-WH STORAGE FOOTBOARD 6/0-6/6
 5930-90353-WH SIDE RAIL 5/0-6/6 RAILS

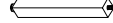
Thank you for purchasing this quality product. Be sure to unpack carefully looking for small parts which may have come loose during shipment.
 Read all instruction and study the drawing carefully before starting the assembly process.

HARDWARE LIST					PARTS LIST			
NO	DRAWING	DESCRIPTION	SIZE	Q' TY	NO	DRAWING	DESCRIPTION	Q' TY
E		Threaded rod	φ5/16"*3-1/2"	8PCS	5		Panel Headboard	1PC
F		Curved Washer	φ5/16"	8PCS	6		Rails	2PCS
G		Nut	φ5/16"	8PCS	10		Storage Footboard	1PC
H		Open Wrench	12mm	1PC	11		Center Slats	2PCS
I		Screw	8*30	26PCS	12		Long support leg for center slat	6PCS
					13		Roll Slats	1PC

STEP 7 : Pull Drawers out from Storage Footboard (10)

STEP 8 : Attach Rails (7) to panel Headboard (5) using Threaded rod (E) Curved Washer (F), Nut (G) and tighten them by open Wrench (H). then push the Drawers into Storage Footboard (10)

STEP 9 : Attach Long support leg (9) to center slats (8) and attach roll slats to the rails tighten them by using a Phillips head screwdriver.

Step 7

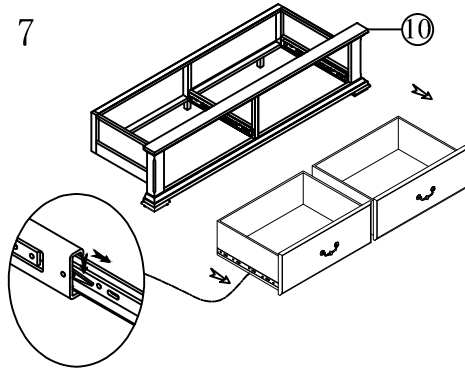

Step 8

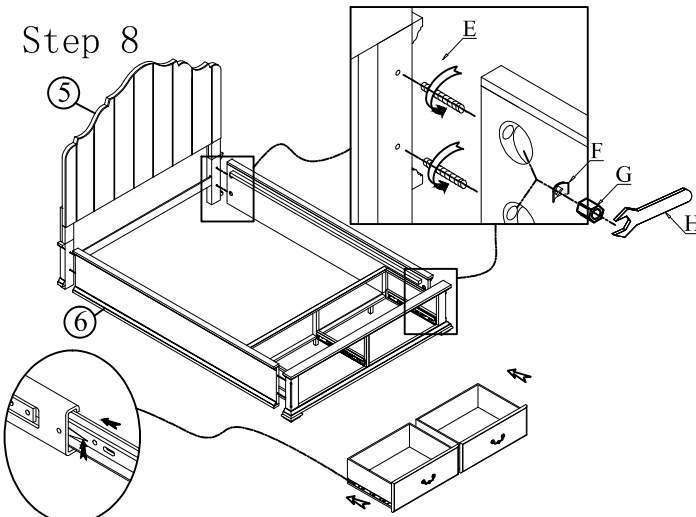

Step 9

