

# GOLDBERG BROTHERS, INC.

## Wagon Wheel Horseshoe Hanger - Installation Instructions

### Included Hardware

Wagon wheel hangers (2)	T-guide (1)	Carriage bolts (6)	Washers (6)	Spacers (6)	Felt Pads (2)
Track stops (2)	T-guide screws (2)	Lock washers (4)	Hex lag bolts (6)	Hex nuts (4)	

### Basic Installation Layouts

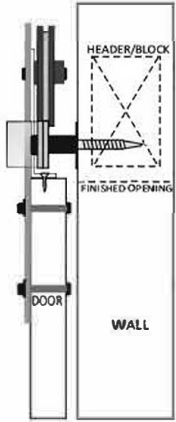

Premium hardware set installed with no casing, base or other trim.

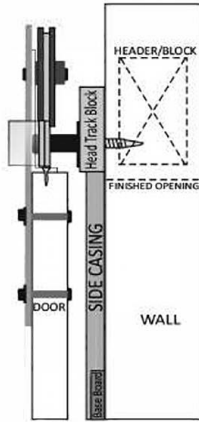

Premium hardware set installed on track trim board that is equal to or thicker than casing, base, or other trim.

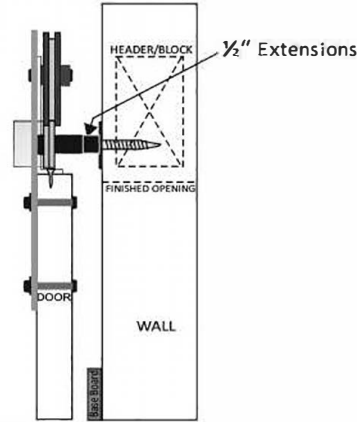

Premium hardware set + 1/2" extension kit installed where casing, base, or other trim is up to 1/2" thick.

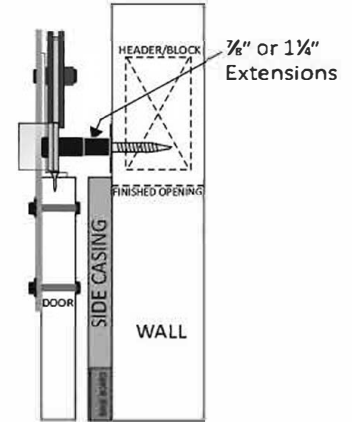

Premium hardware set + 3/8" or 1/4" extension kit installed where casing, base, or other trim is up to 3/8" thick.

### Door Prep and Hanger Installation

At 3" and 9" from both sides of the top half of the door, measure down 1 1/4" and drill 1/8" pilot holes followed by 3/8" holes. 6" from both sides of the top half of the door, measure down 4 1/4" and drill 3/8".

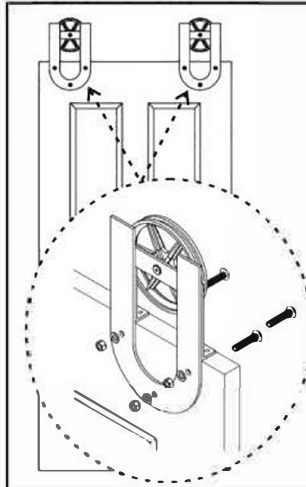
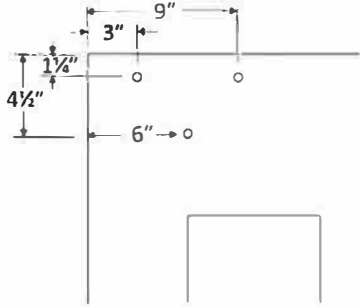

Using the carriage bolts, hex nuts and lock washers, attach the wagon wheel hangers to the door as shown in the diagram.

**Note:** The hanger support brackets should be fastened to the top of the door using the provided screws.

### T-guide Installation

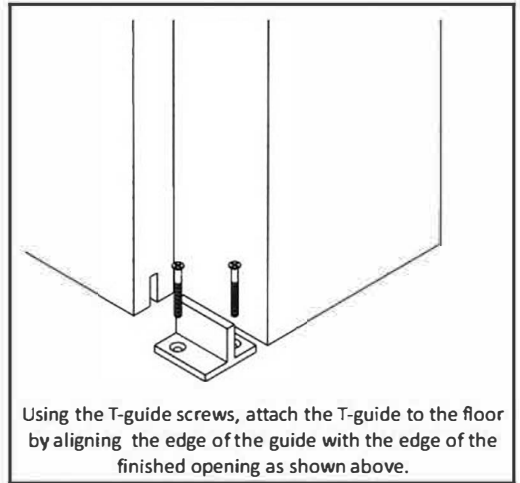

Using the T-guide screws, attach the T-guide to the floor by aligning the edge of the guide with the edge of the finished opening as shown above.

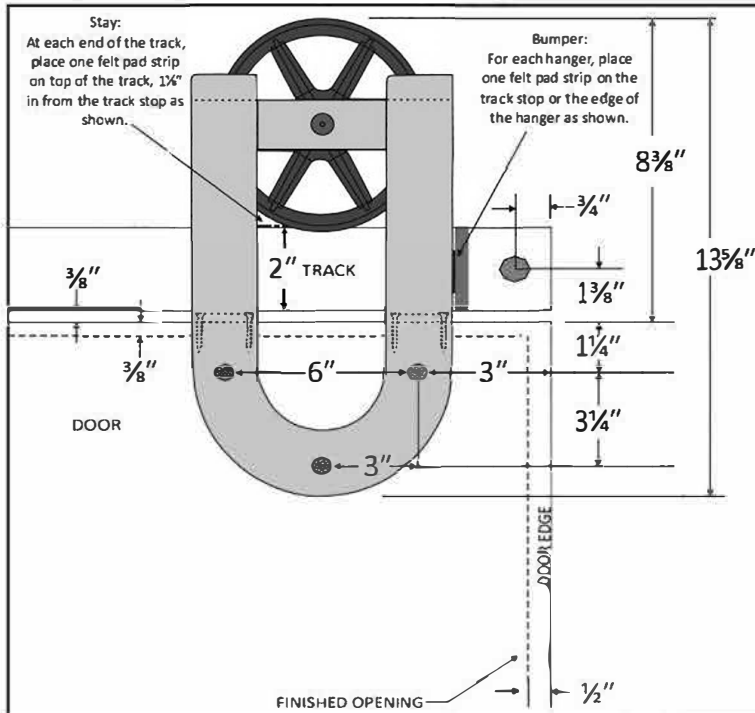

In the closed position, the door should overlap the wall a minimum of 1/4" at the top and a minimum of 1/2" on both sides.

The edge of the door should align with the end of the track.

Plumb the door before fastening door guide to floor.

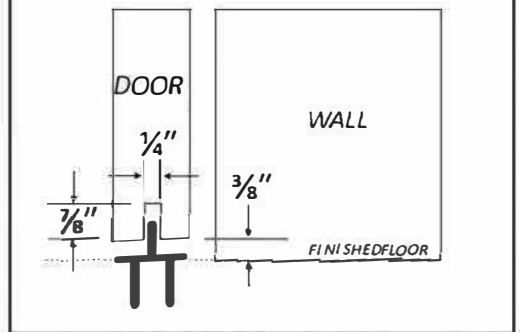

Goldberg Brothers barn door track and hardware sets come with a one-year manufacturer's warranty for defective parts under normal installation and use. Warranty is subject to repair or replacement of defective components at manufacturer's discretion and does not include installation costs.

Goldberg Brothers does not warrant the loss of finish at points where roller is in contact with track. Goldberg Barn Track is sold as a rustic finished hardware and Goldberg does not warrant the imperfections seen through the finish in the steel parts. It is part of the look.

With the exception of our stainless steel products, Goldberg Brothers does not warrant any products installed and used outdoors or where they are exposed to weather, running water or water condensation. Under these conditions, rust and other damage will naturally occur.

This warranty does not include loss of defects caused by elements outside the control of Goldberg Brothers, Inc., such as natural disasters, weather, fire, water leakage, abuse, improper installation, or anything else deemed out of the control of Goldberg Brothers, Inc.

# Track Installation

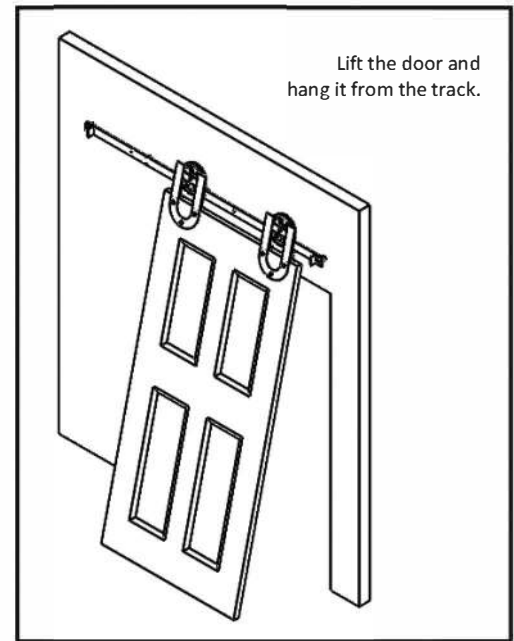
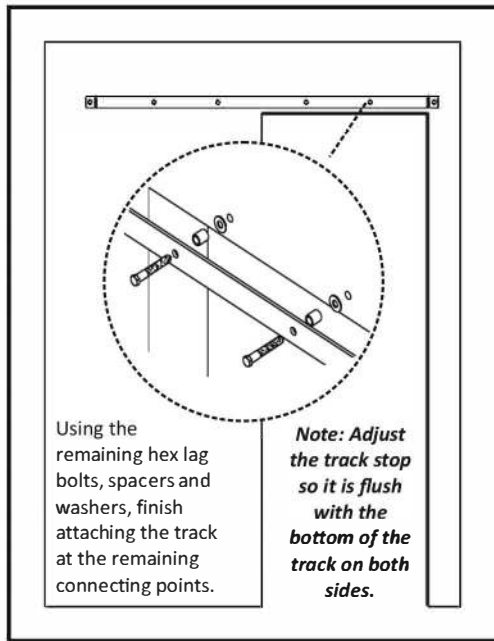
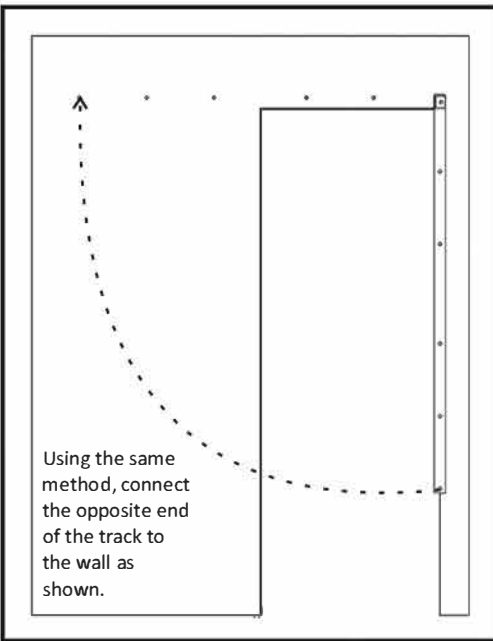
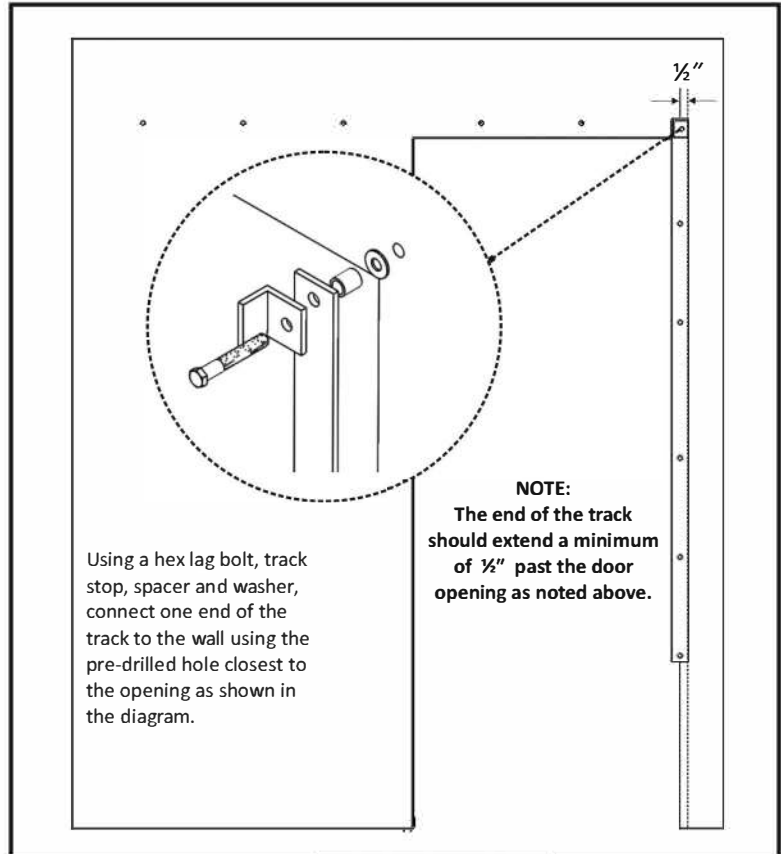
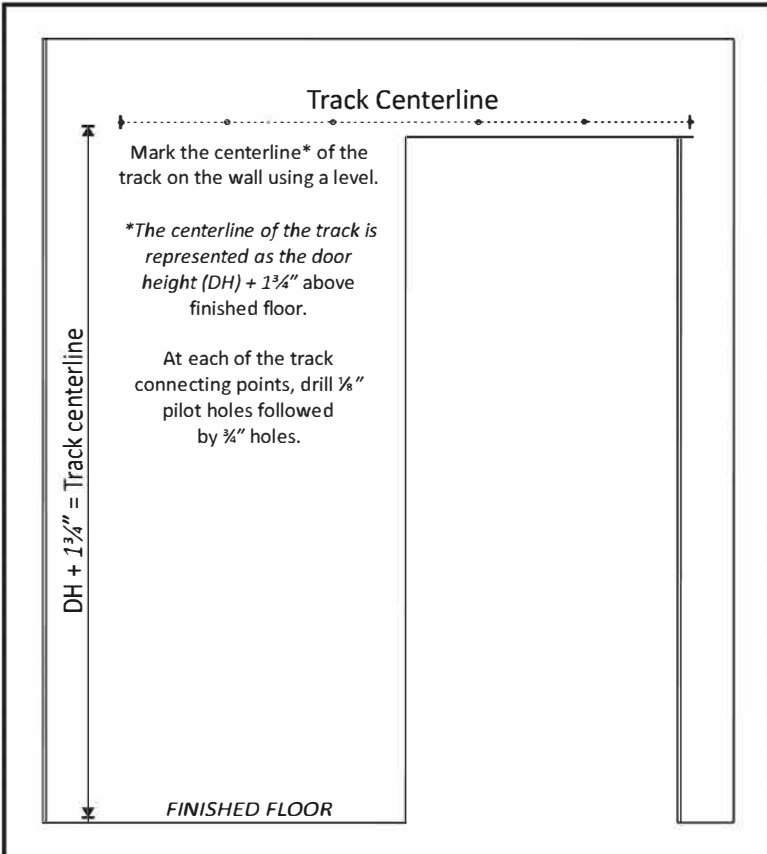

## Optional Accessories

Wall Extension Bolts Set  
Includes 6 lag bolts and 6 wall spacers



	1 1/2" Door	1 3/4" Door	2 1/4" Door
1/2" Extension	Part #60013E*	Part #60013EX*	Part #60013EXX*
3/4" Extension	Part #60014E*	Part #60014EX*	Part #60014EXX*
1 1/4" Extension	Part #60015E*	Part #60015EX*	Part #60015EXX*

Track Connecting Plate  
1 each  
Part #6001C.\*

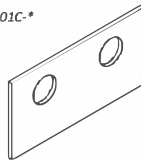

Door Guide "U"  
1 set  
Includes 2 "U" guides, 2 wood screws and 1 felt pad  
Part #6001U.\*

NOTE: Use the provided T-guide screws for U-guide installation.

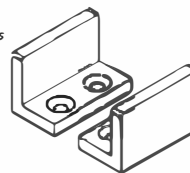

Sidewall Guide Bracket  
1 each  
Includes 1 bracket, 4 machine screws, 4 nuts and 1 felt pad  
Part #6001SW\*

NOTE: Use the provided T-guide screws for sidewall guide installation.

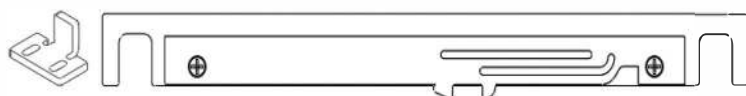
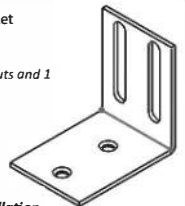

Soft Stop  
1 set  
Includes 2 Soft Stop mechanisms, 2 triggers and 4 wood screws  
Part #6001SOFT11 (4'-7" track)  
Part #6001SOFT17 (8'+ track)



Goldberg Brothers, Inc.  
10488 W Centennial Rd, Suite 100  
Littleton, CO 80127  
(303) 321-1099

\* Indicates that the related part is available in various colors.