

Endura-Stone Installation Instructions



1. Measure the total distance from the bottom of the beam to the platform.



2. Using a jack and post, jack up the beam only enough to remove the sting post, no more than 1/4



3. Determine the top centerline and mark it on the beam.



4. Hang a plumb bob from the top centerline to determine the bottom centerline.



5. Mark the bottom centerline point.



6. Using a square, draw a centerline perpendicular to the outside edge of the platform.

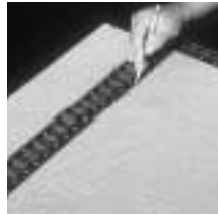

7. Draw a centerline parallel to the outside edge.



8. Measure from the top of the column to the proper length and make a series of marks around the column shaft.



9. Using a piece of cardboard as a guide, draw a line all the way around the column.



10. Cut the column using an abrasive circular saw. CAUTION: Because the column is load bearing, its top and bottom edges must be level to achieve full, even contact. Between the load surfaces and the shaft. Use a rasp to level as required.



11. Mark and drill clearance holes on the top and bottom of the column to accommodate bolts for the 1 1/2" L-brackets. (L-brackets sold separately.)



12. Slide cap over the top of the column to rest on the neck ring, then slide the base onto the column.



13. Secure two L-brackets on the top and bottom of the column using throughbolts. Do not use screws and do not over tighten.



14. Apply construction adhesive to the top and bottom of the column.



15. Put the assembly in place and plumb. Make sure that the load is centered over the column shaft and evenly distributed. Secure L-brackets to the platform and beam.



16. Apply construction adhesive to the cap and base.



17. Align the square part of the base with the platform below and push the base down until secure.



18. Slide the cap up to the beam and push up until secure. Screws may be used to secure the cap to the beam and the base to the platform. (When using screws, first drill pilot holes and fill with putty to cover screw heads.)



19. Apply caulk to gaps between the cap and base and the column shaft.



20. Prepare the column for painting by sanding lightly with 120-grit or finer wet/dry sandpaper.



21. Remove dust by wiping the column, cap, and base with soap and water.



22. Paint the column with a high-quality oil-base or acrylic-latex paint.

Endura-Stone Installation Instructions

1. Measure the exact floor to ceiling height using a plumb to insure accuracy.
2. Cut the bottom of the column shaft as needed to achieve the measurement taken in step 1. Use an abrasive blade. **CAUTION:** Because only the shaft is load bearing, its top and bottom edges must be level to achieve full, even contact between load surfaces and shaft**. Use a rasp to level as required. **NOTE:** All height adjustments must be made from the bottom of the shaft. For the cap to fit correctly, the top of the shaft must be trimmed only enough to achieve level contact with load surfaces, or to achieve correct installation of decorative capitals.
3. Slip one-piece cap and base onto column shaft (see figure 1). The two-piece cap and base are attached after then shaft is installed. If this column is installed where it could collect water or debris, the top of the column and cap **MUST** be flashed (covered) to prevent such collection. Use lead, copper, aluminum, galvanized, etc. flashing cut slightly larger than the cap, and fold the edges down over the cap after step 5. It is not permissible at any time to fill the interior of the column shaft with sand, concrete or any other material.
4. If installation requires some method of securing the column in place before load is applied, use Endrua-Stone Installation Kit #71760 (see figure 2) **NOTE:** Always drill clearance holes in columns and secure with through-bolts — **DO NOT USE SCREWS** — and do not over-tighten.
5. Apply standard construction adhesive to flashing (if used), top surface of cap and bottom surface of base; then tip loosely assembled column shaft into position, align flashing (if used), and lower load onto shaft to hold it in position. Align square part of cap with load surface (or flashing) above and push up against it to secure. Align square part of base with load surface below cap and push down until it is secure.
6. Caulk gaps between shaft and cap and base as desired.
7. All round columns are factory sanded. All surfaces of cap and base, square columns, and the concave area at the bottom of the flutes on fluted columns require preparation by sanding with 80 to 100 grit sandpaper. Sand to remove all glossy areas. Always follow the instructions of the paint manufacturer. A. To paint with oil base paint, remove all dust and dirt by thoroughly wiping column with cleaner compatible with your chosen paint. Allow to dry completely. Use a high quality oil base paint. Primer is not needed if the oil base paint is the desired color. B. To paint with acrylic latex paint, we recommend using a high quality primer like Sherwin-Williams® PrepRite® Anchor-Bond and a topcoat like Sherwin-Williams® SuperPaint®. Remove all dust and dirt before painting by thoroughly cleaning with a cleaner like Simple Green® or isopropyl alcohol. Allow to dry completely before priming.
8. Columns may be split to cover lally columns, posts, etc. using an abrasive Carborundum or carbide blade. **NOTE:** Split columns are not load bearing.

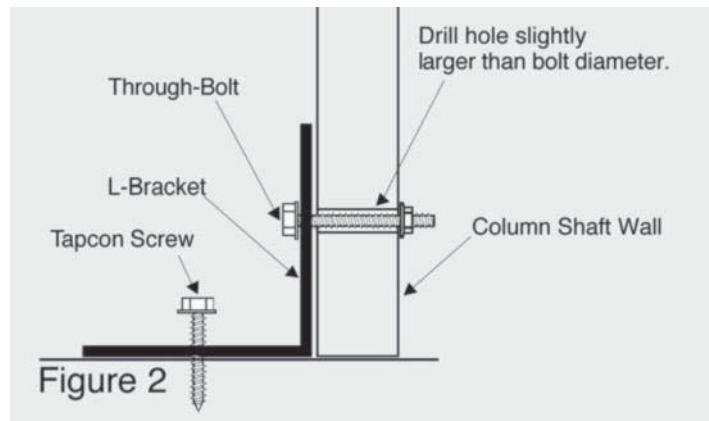
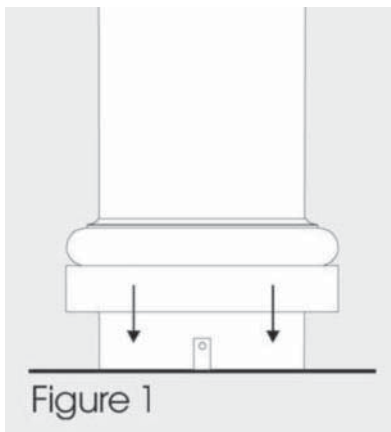

*Please check your local building codes to determine whether Endrua-Stone columns are applicable for your needs.
**Installing column shaft off-center from overhead beam will reduce load bearing capacity.

Endura-Stone Installation Instructions

Instructions for Attaching Handrails to Pacific Columns Endrua-Stone® Columns

Rail to Column Kit #71758

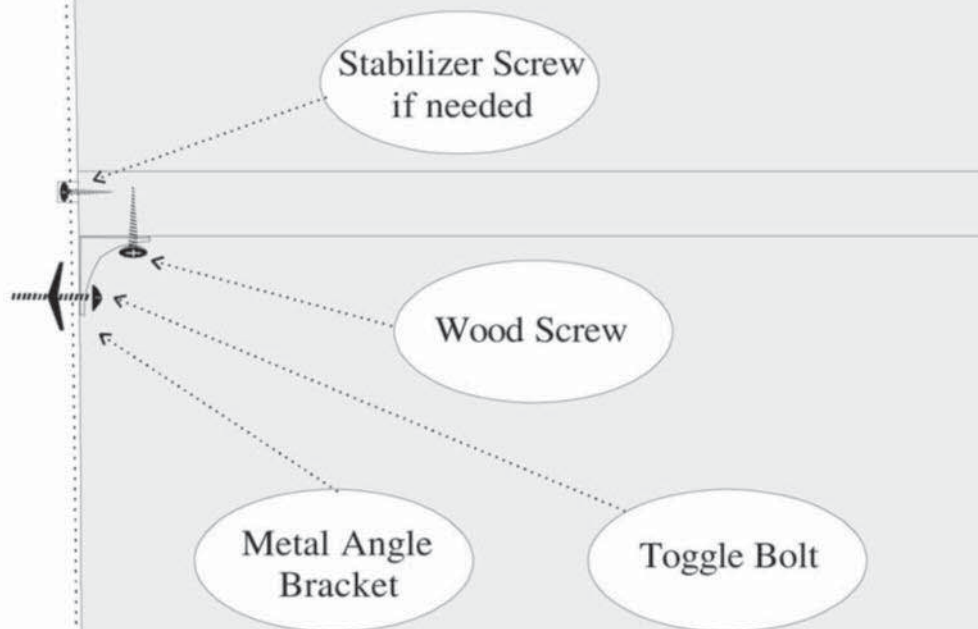

1. Trace the curve of the column (a contour gauge is helpful) at the desired rail height.
2. Copy the curve to the end of the rail which will be attached to the column.
3. Carefully cut the end of the rail to ensure an attractive, tight fit.
4. Attach metal Angle Bracket to the bottom of railing using rust proof wood screws.
5. Mark desired spot on column shaft.
6. Drill pilot hole in wall of column, slightly larger than toggle bolt.
7. Attach angle bracket to column wall with toggle bolt. The toggle bolt will spread any force applied over a wide area of the inside of the column. Do Not Over-tighten!

(Note: the stabilizer screw is not included. It would be used to prevent rotation of the rail. A hole the same size as your screw head is drilled through the column. The screw is driven into the end of the rail. The screw head slips into the hole in the column shaft, keeping the rail from turning.)

Endura Stone Non-Load Bearing Decorative Capitals / Installation Instructions

A. PARTS AND SUPPLIES NEEDED FOR INSTALLATION

Hardware not included:

The following will need to be purchased before beginning installation.

Standard construction adhesive

Mineral spirits - for cleaning

High quality primer and topcoat paint

B. PREPARATION

1. General – Good industrial / construction hygiene practices demand that when grinding, cutting, or sanding our products, you must work in a well-ventilated area and wear protective safety equipment, such as gloves, safety glasses and a MSHA/NIOSH approved respirator.

C. INSTALLATION OF DECORATIVE CAPITALS

1. Before installing the decorative capital, cut the column at the top of the shaft just above the neck ring. Cut within 1/8" from the neck ring and belt sand flush to finish (see Fig. A).

2. **Before cutting the bottom of the column shaft** measure the opening where the column will be installed. When calculating the overall height required be sure to include the height of the capital and plug. The plug will be 1/8" to 3/16" higher than the capital. Trim the column shaft bottom to fit the height of the opening AFTER cutting the top of the shaft at neck ring.

*NOTE: Column may be trimmed using an abrasive saw blade or a fine-toothed hand saw. The capital may be trimmed using a Sawzall® with a 10" / 14" tooth saw blade.

3. To attach the plug to the capital: Turn the capital over with the base facing up.
4. Cut two '2x6's – 1 foot in length and place halfway across the base of capital at opposite ends.
5. Trace the capital radius on the '2x6's and cut.
6. Put adhesive on the base of the capital, turn over and center over the metal plug.
7. Using a steel drill, drill three 5/32" holes in each radius piece through the steel plate.
8. Screw a #10 sheet metal screw into each of the six holes. On the outside of the capital, countersink and pilot drill a 7/64" hole through the base of the capital into each radius '2x6' and secure with a screw.
9. Apply a good grade of construction adhesive between the top of the column shaft and the bottom of the capital (See Fig. B).
10. USE CARE when positioning the capital on top of the column. Large capitals may require a forklift.
11. PICK UP THE CAPITAL FROM THE BOTTOM OF THE STEEL PLATE ONLY. It is important to center the capital on top of the column. Remove any excess adhesive.
12. Countersink and pilot drill four 7/32" screw holes into the top of the neck ring through the 3/4" plywood on the plug bottom. These holes should be level with the plywood. Screws should be long enough to penetrate the base of the capital (See Fig. B).
13. Secure the capital with #10 or #12 rustproof screws. Do not over tighten. Length of the screws will depend on the size of the capital and neck ring.
14. Lower the soffit onto the plug. Since the plug will be 1/8" to 3/16" higher than the capital, you should add shims to fill the gap between the soffit and capital.
15. To install the shims, countersink and pilot drill a 7/32" hole through the capital, shims and soffit and secure with a screw. Follow the column manufacturer's installation instructions.

Endura Stone Non-Load Bearing Decorative Capitals / Installation Instructions

D. OPTIONAL INSTALLATION INSTRUCTIONS TO COVER THE CAVITY OF THE CAPITAL

1. Using a 3/8" or 1/2" Marine grade plywood, place the plywood on the top of the capital and trace an outline of the capital.
 2. Over cut the tracing by 1/4".
 3. Apply a premium grade of silicone between the plywood and the capital top.
 4. Screw the plywood to the capital using stainless steel screws.
 5. Caulk the back edge of the plywood where it meets the soffit with silicone adhesive.
6. You may also use flashing, or a combination of both flashing and plywood. There is no need to bend the flashing over the edge of the capital. This product is rot proof and impervious to water.

E. FINISHING

1. Finish by caulking all seams and drill holes.
2. Repairs to the capital may be made using automotive adhesive such as Bondo®.
3. Apply a high quality primer to both the column and capital.
4. Finish with a premium grade of topcoat paint (see Fig. C).

OTHER INFORMATION

It is always advisable to check your local building codes before starting construction. If you have any questions regarding these installation instructions and your local building code requirements, please contact Pacific Columns before starting installation.

It is recommended that safety gloves, hats and goggles, as well as other specified safety equipment be used during installation and construction.

Pacific Columns, shall not be responsible if any failure to comply with these instructions results in the product failing to perform the purpose intended. Failure to comply with the above instructions shall result in voiding the terms and conditions as stated in the warranty.

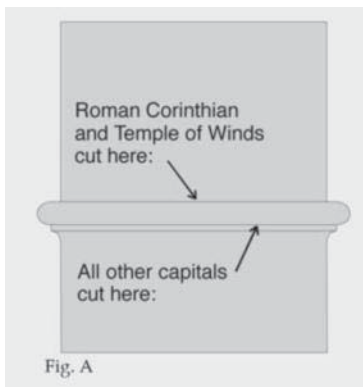

Fig. A – Cut Column at neck ring when installing decorative capitals.

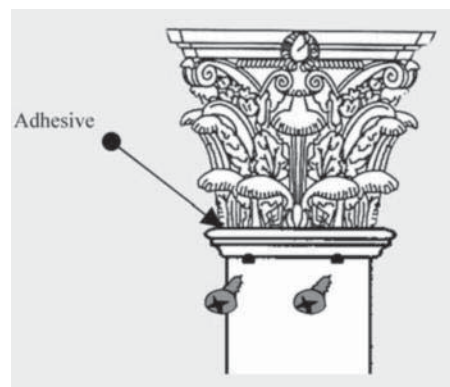

Fig. B – Apply adhesive between the top and bottom of capital.



Fig. C – Apply a high quality primer before painting.

Endura Stone Load Bearing Decorative Capitals / Installation Instructions

A. PARTS AND SUPPLIES NEEDED FOR INSTALLATION

Hardware not included:

The following will need to be purchased before beginning installation.

- Standard construction adhesive
- Mineral spirits - for cleaning
- High quality primer and topcoat paint

B. PREPARATION

1. General – Good industrial / construction hygiene practices demand that when grinding, cutting, or sanding our products, you must work in a well-ventilated area and wear protective safety equipment, such as gloves, safety glasses and a MSHA/NIOSH approved respirator.

NOTE: Decorative Capitals are load bearing to meet the level of load bearing capacity of the column.

C. INSTALLATION OF DECORATIVE CAPITALS

NOTE: Steel and wooden plugs are not needed for installation of Decorative Capitals – except where noted in product specifications. See separate installation instructions for Non-Load Bearing Capitals.

1. Before installing the decorative capital, cut the column at the top of the shaft just above the neck ring. Cut within 1/8” from the neck ring and belt sand flush to finish (see Fig. A).
2. Before cutting the bottom of the column shaft – measure the opening where the column will be installed. When calculating the overall height required be sure to include the height of the capital. Trim the column shaft bottom to fit the height of the opening.

NOTE: Column may be trimmed using an abrasive saw blade or a fine-toothed hand saw. The capital may be trimmed using a Saw-zall® with a 10” / 14” tooth saw blade.

3. Apply a good grade of construction adhesive between the top of the column shaft and the bottom of the capital (See Fig. B).
4. Center the capital on the top of the column. Remove any excess adhesive.
5. Countersink three [3] screw holes below the neck ring up through the base of the capital. Screws should be long enough to penetrate the base of the capital (see Fig. B).
6. Secure the capital with three galvanized or stainless steel [rust-proof] screws. Do not over tighten.
7. Raise soffit and slide assembled column with attached capital into place. Follow the column manufacturer’s installation instructions.

D. INSTALLATION OF SPLIT COLUMNS AND CAPITALS

NOTE: Split columns and split capitals are not load bearing.

1. Join the two capital half’s using a good grade of construction adhesive. Caulk all seams and finish as described below.

E. FINISHING

1. Finish by caulking all seams and drill holes.
2. Repairs to the capital may be made using automotive adhesive such as Bondo®.
3. Apply a high quality primer to both the column and capital.
4. Finish with a premium grade of topcoat paint (see Fig. C).

Endura Stone Load Bearing Decorative Capitals / Installation Instructions

OTHER INFORMATION

It is always advisable to check your local building codes before starting construction. If you have any questions regarding these installation instructions and your local building code requirements, please contact Pacific Columns before starting installation.

It is recommended that safety gloves, hats and goggles, as well as other specified safety equipment be used during installation and construction.

Pacific Columns, shall not be responsible if any failure to comply with these instructions results in the product failing to perform the purpose intended. Failure to comply with the above instructions shall result in voiding the terms and conditions as stated in the warranty.

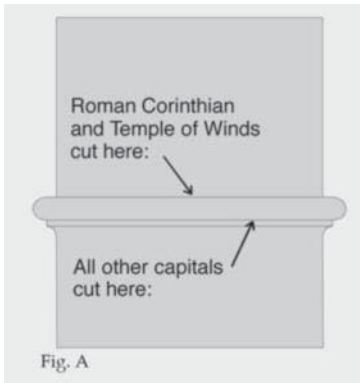

Fig. A – Cut Column at neck ring when installing decorative capitals.

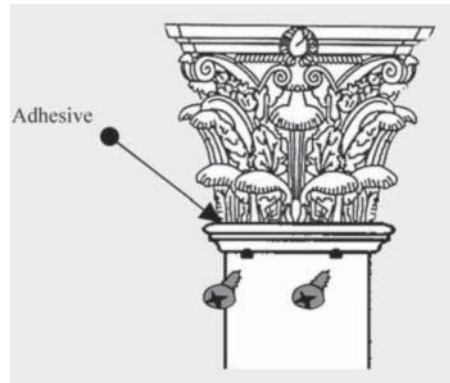

Fig. B – Apply adhesive between the top and bottom of capital.



Fig. C – Apply a high quality primer before painting.

Endura-Stone Fire Test

Endura Stone Pass Flame Spread and Smoke Density Test

OVERVIEW

Pacific Columns Endrua-Stone Columns now pass the ASTM E, 84-01, "Standard Test Method for Surface Burning Characteristics of Building Materials" (NFPA 255, ANSI/UL 723 and UBC 8-1).

FEATURES & BENEFITS

Endrua-Stone Columns now have a Flame Spread Index (FSI): of 15. This index puts the Endrua-Stone Column in a Class I Flame-Spread classification under the 1997 uniform fire code. This is an industry first for FRP columns.

Endrua-Stone Columns also have a Smoke Developed Index (SDI) of 335. This index is well below the allowable SDI index of 450. This is also an industry first for FRP Columns.

Industry standard FRP columns have a typical Flame Spread Index (FSI) of 70-85 and a Smoke Developed Index (SDI) of 900-1025.

APPLICATIONS

Endrua-Stone Columns now pass the ASTM E, 84-01 test for interior applications in markets where the building code officials have started to enforce Section 318 of the 1995 CABO One and Two Family Dwelling Code or Section 803.3.2 of the 1996 BOCA National Building Code.

SPECIFICATIONS

Test Data

UNROUNDED FSI 15.5

UNROUNDED SDI 335.8

FS*TIME AREA (Ft*Min) 30.2

SMOKE AREA (%*Min) 273.2

OBSERVATIONS DURING TEST

IGNITION TIME (Min:Sec) 3:31

MAXIMUM FLAME FRONT ADVANCE (Ft.) 7.0

TIME TO MAXIMUM ADVANCE (Min:Sec) 10:00

MAXIMUM TEMP. AT EXPOSED TC(*F): 563

TIME TO MAXIMUM TEMP. (Min:Sec) 9:57

TOTAL FUEL BURNED (Cu.Ft.) 52.4

DRIPPING (Min:Sec) None

FLAMING ON FLOOR (Min:Sec) 8:15

AFTERFLAME TOP (Min:Sec) 3:00+

AFTERFLAME FLOOR (Min:Sec) 3:00+

Full test results available on request.