

ASSEMBLY INSTRUCTIONS

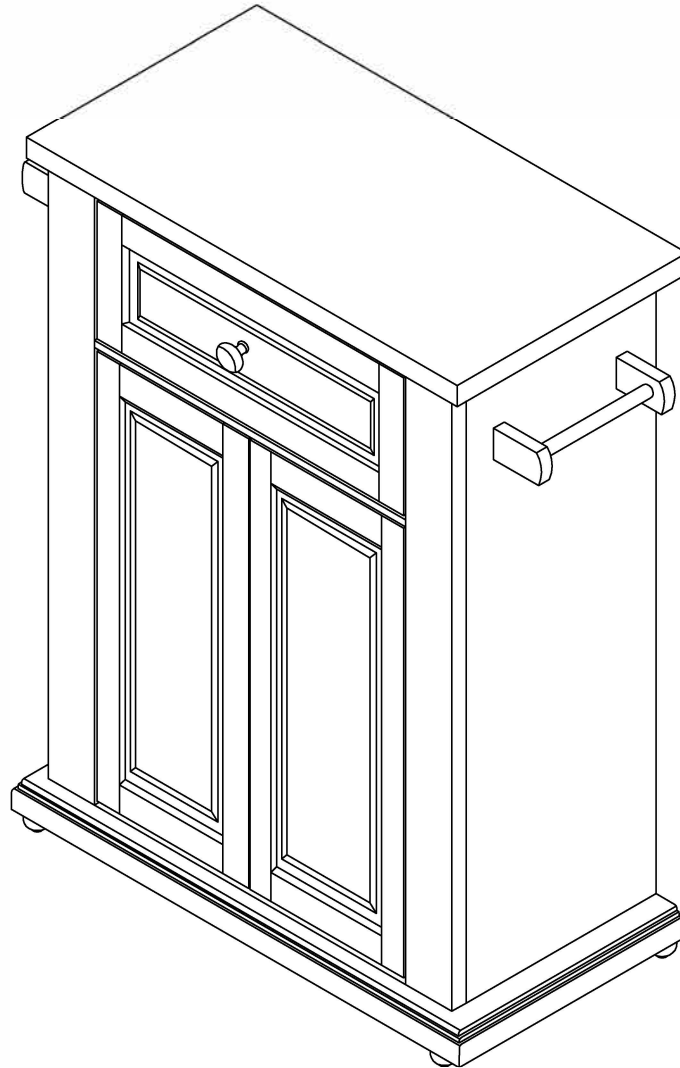

NOTE TO CUSTOMERS:

- For ease and speed of assembly we recommend that before you commence each step of the assembly that you identify all the parts required to complete that step.
- We recommend that where possible you allow sufficient space to assemble the item as close as possible to the place where it will be once assembled.
- For the protection of your furniture we recommend that the product is placed on protected surfaces during assembly to prevent any damage.
- During assembly do not over tighten, as this may damage the product.
- Please ensure you retain all the product packaging until the item completely assembled.
- Please periodically check all fittings and re-tighten as necessary.
- Please never allow any liquids to remain on your furniture as absorption can cause the wood to warp or the finish to de-laminate.
- It is recommended that this item should be assembled by two adults.

To insert a cam lock: (Please read below instructions before assembling)

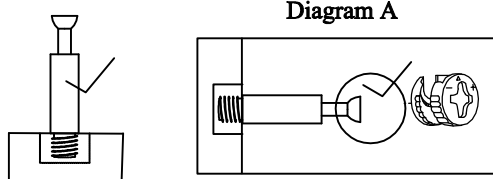

Diagram A

1. Insert cam screw into hole as shown in diagram A .

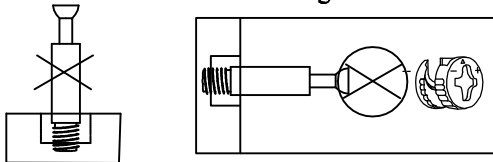

Diagram B

Make sure not to insert the cam screw:
Too deep as shown in figure B as this will cause the
cam screw to be misaligned and unable to
interlock properly.

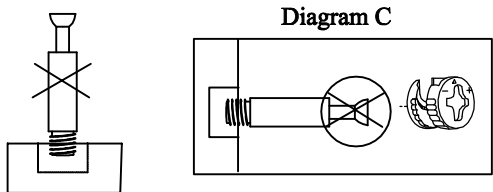
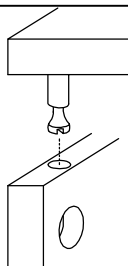
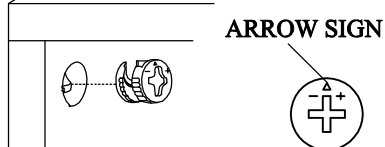

Diagram C

Also avoid inserting the cam screw too close to the
surface of the hole as shown in figure C, as this will
cause the cam lock to be too loose, and not interlock
properly.



2. Connect the panels together.



ARROW SIGN

3. When inserting the cam lock make sure the arrow
of the cam lock faces the cam screw.

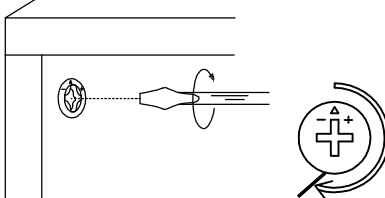







4. To tighten the cam lock turn the cam lock clockwise
90-180 degree or until the arrow is facing opposite
the place cam lock was inserted.

**NOTE: DO NOT USE AN AUTOMATIC
SCREWDRIVER TO TIGHTEN CAM LOCKS.**

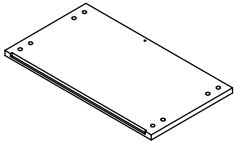
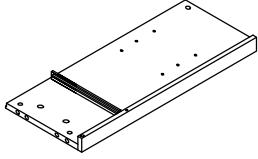
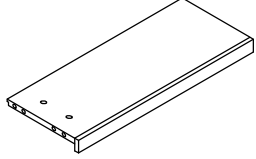
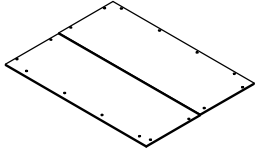
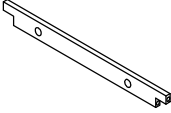
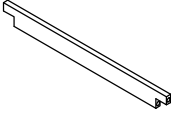
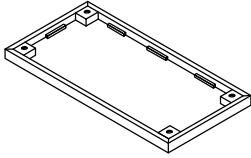
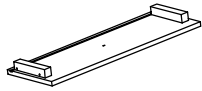



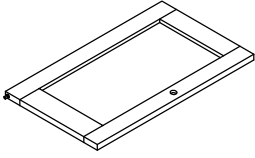
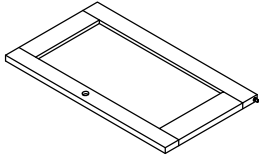
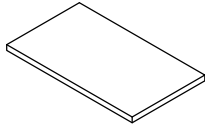

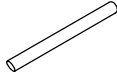

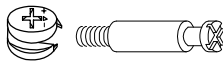

Note:

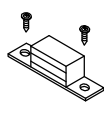
- Read these instructions carefully before assembling.
- Tools required : Phillips screwdriver, flat screwdriver.
- Find a clean, smooth area on which to work , such as a carpet, in order to avoid scratching the wood surfaces.
- Wait to dispose of the packing material until assembly is complete and all parts and hardware are accounted for.
- Two or more people might be required for assembly.

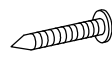
Part List

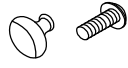
<p>A1 Quantity of 1</p>  <p>Top Panel</p>	<p>A2 Quantity of 1</p>  <p>Left Side Panel</p>	<p>A3 Quantity of 1</p>  <p>Right Side Panel</p>	<p>A4 Quantity of 1</p>  <p>Back Panel</p>
<p>A5 Quantity of 1</p>  <p>Top Support Bar</p>	<p>A6 Quantity of 1</p>  <p>Middle Support Bar</p>	<p>A7 Quantity of 1</p>  <p>Bottom Panel</p>	<p>A8 Quantity of 1</p>  <p>Drawer Front Panel</p>
<p>A9 Quantity of 2</p>  <p>Drawer Side Panel</p>	<p>A10 Quantity of 1</p>  <p>Drawer Bottom Panel</p>	<p>A11 Quantity of 1</p>  <p>Drawer Back Panel</p>	<p>A12 Quantity of 1</p>  <p>Left Door</p>
<p>A13 Quantity of 1</p>  <p>Right Door</p>	<p>A14 Quantity of 1</p>  <p>Adjustable Shelf</p>	<p>A15 Quantity of 4</p>  <p>Leg</p>	<p>A16 Quantity of 4</p>  <p>Bar</p>
<p>A17 Quantity of 2</p>  <p>Towel Bar</p>			

Hardware List

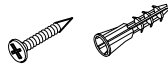
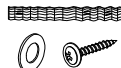
A Quantity of 8	B Quantity of 20	C Quantity of 1	D Quantity of 1	E Quantity of 8
				
Camlock	Wood Dowel	Magnet with Screw	Stopper with Screw	Bolt
F Quantity of 2	G Quantity of 16	H Quantity of 8	I Quantity of 3	J Quantity of 4
				
Screw	Screw	Screw	Knob with Bolt	Shelf Support
K Quantity of 4	L Quantity of 4	M Quantity of 1	N Quantity of 1	O Quantity of 1
				
Pin	Nut	Allen Wrench	Anchor with Screw	Anti-tip Kit



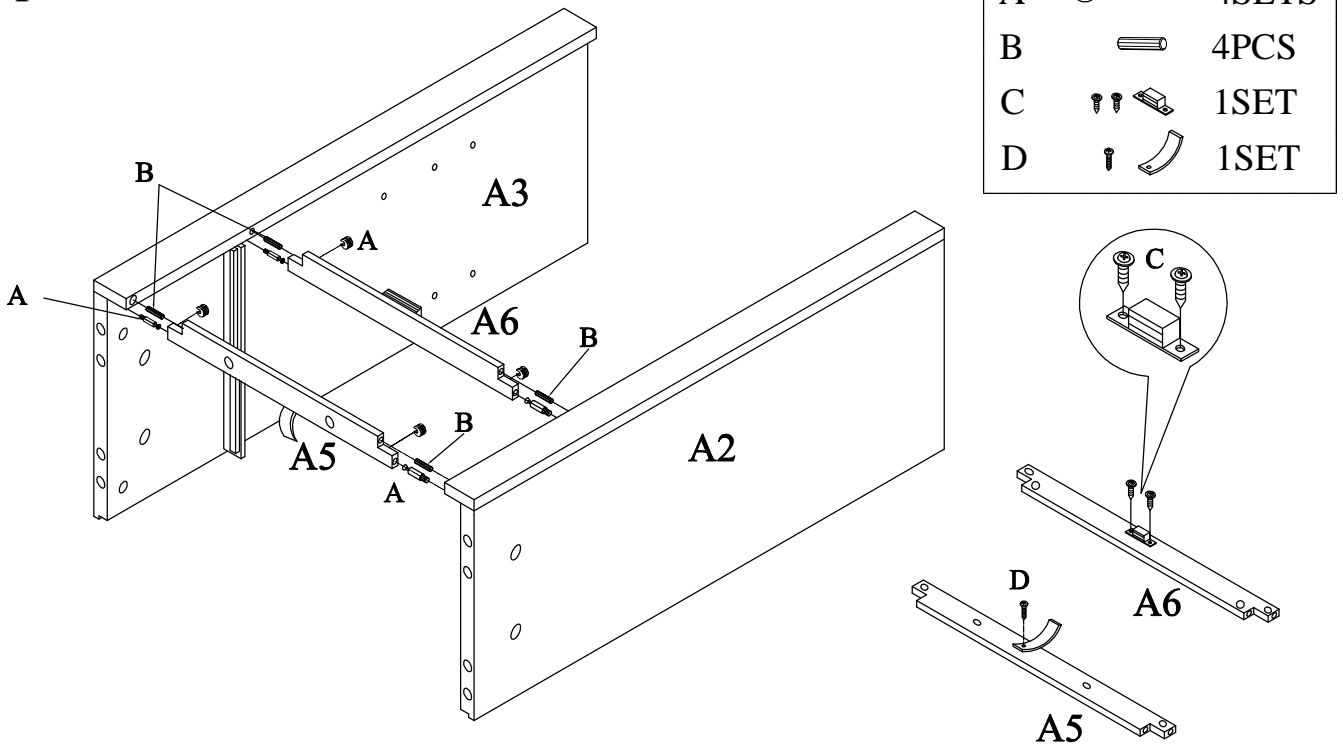

Step 1

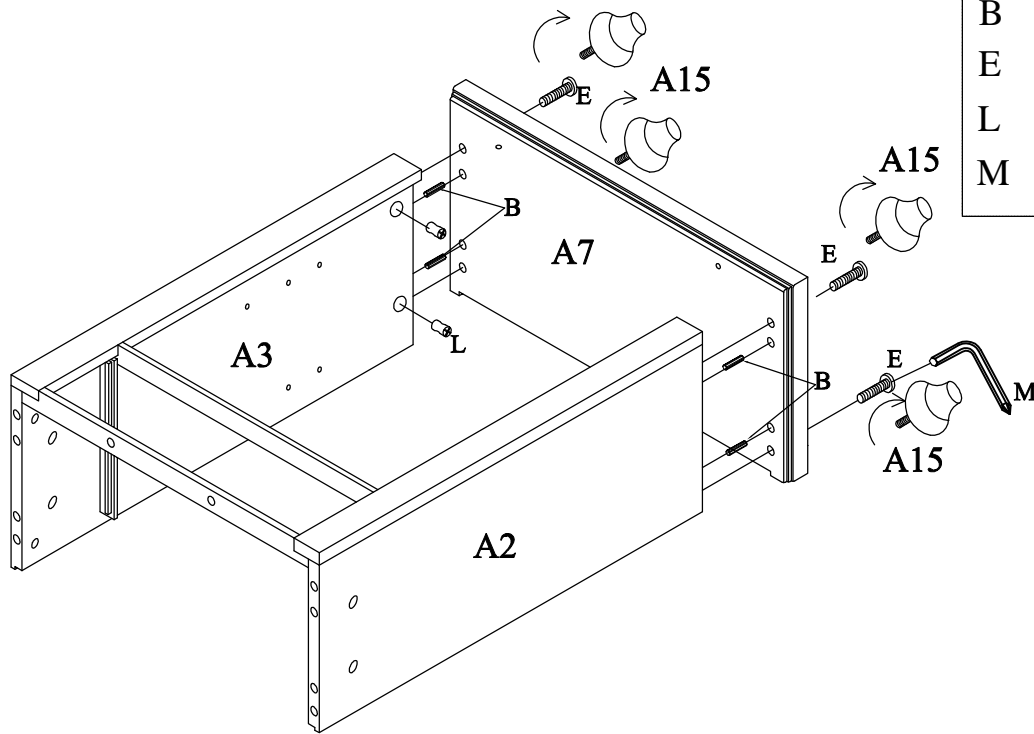

- 1): Attach Stopper D to Top Support Bar A5 with included screw.
- 2): Attach Magnet C to Middle Support Bar A6 with included screws.
- 3): Assemble Support Bars A5 & A6 to Side Panels A2 & A3 using Camlocks A and Wood Dowels B.

Step 2





B		4PCS
E		4PCS
L		4PCS
M		1PC

- 1): Attach Legs A15 to the bottom of Bottom Panel A7 as shown above.
- 2): Assemble Bottom Panel A7 to Side Panels A2 & A3 using Wood Dowels B and Bolts E with Nuts L.

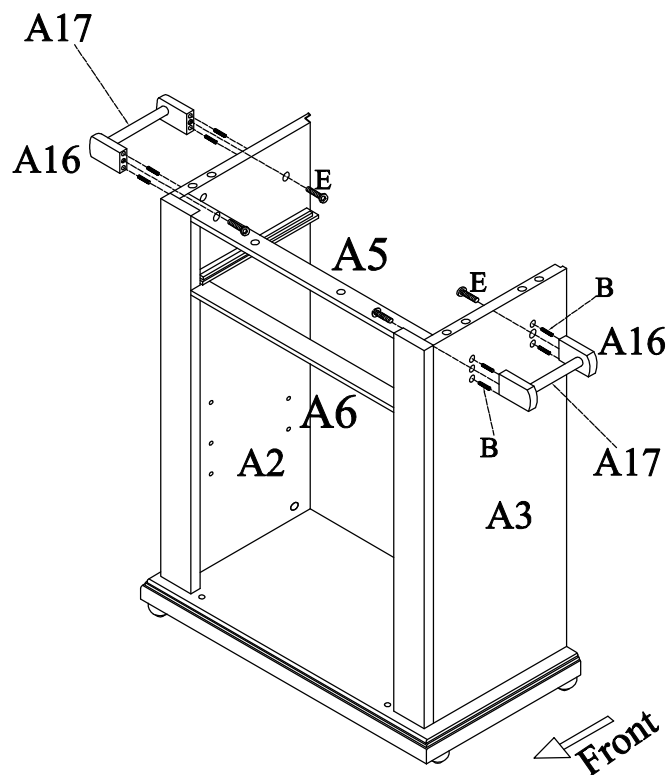
Step 3



B		8PCS
E		4PCS

- 1): Insert Towel Bar A17 into Bars A16 ,then assemble Bars A16 to Left Side Panel A2 using Bolts E and Wood Dowels B.
- 2): Repeat the above step to assemble another Towel Bar A17 & another Bars A16 to Right Side Panel A3.

Step 4

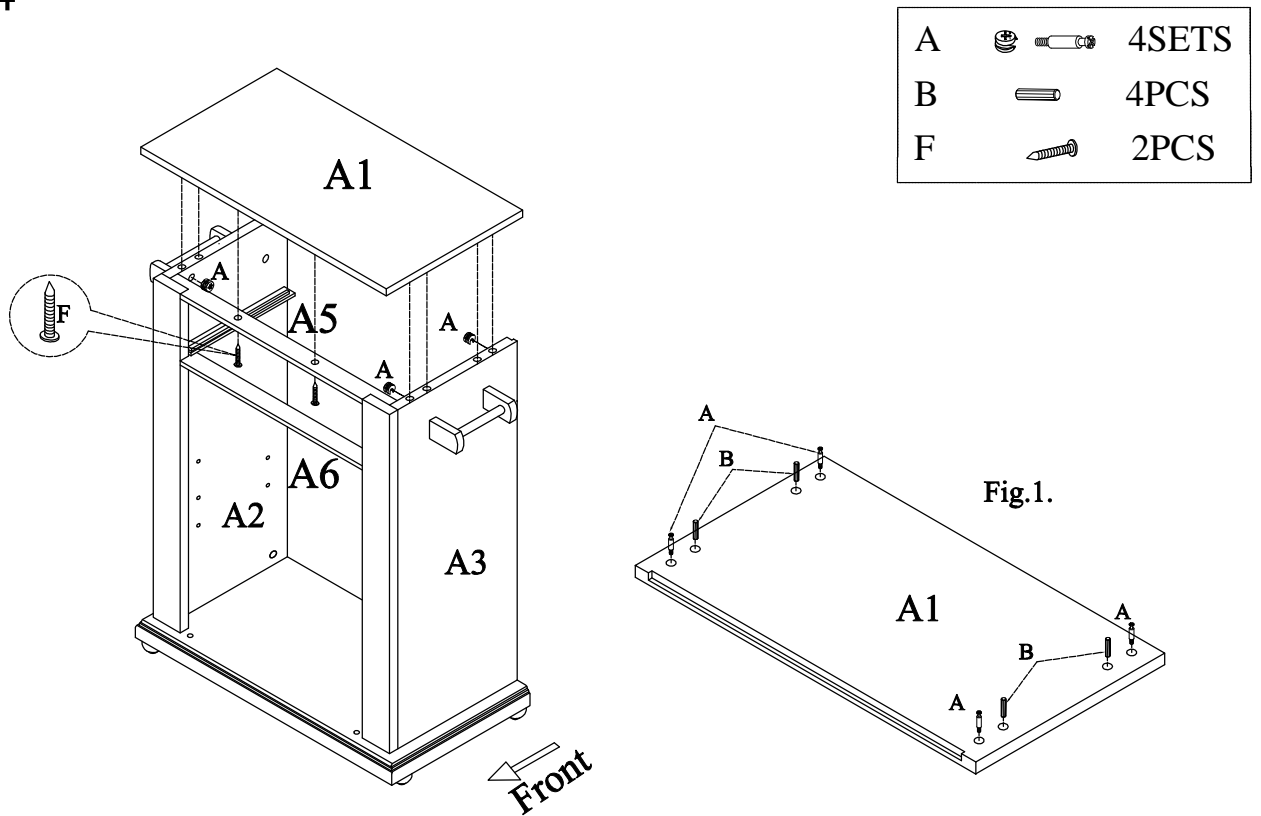

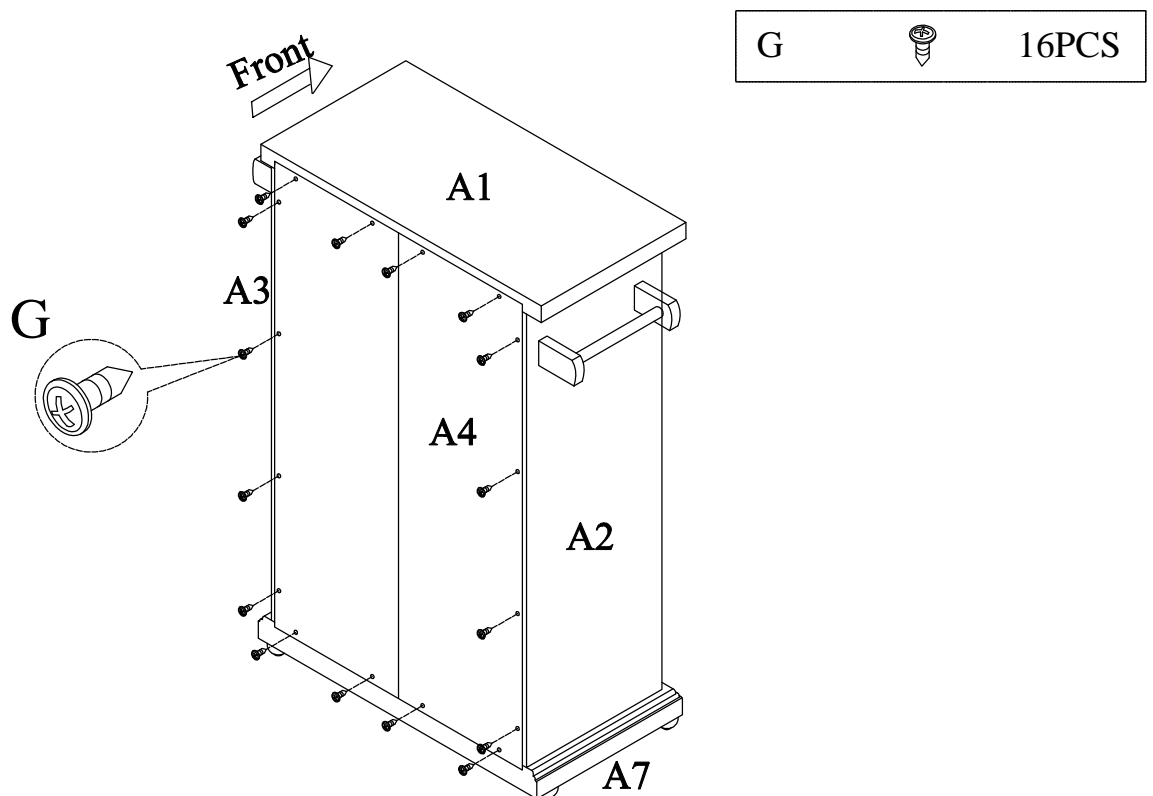

- 1): Insert Wood Dowels B into the bottom of Top Panel A1 and tighten Cam-bolts A, refer Fig.1. Then assemble Top Panel A1 to Side Panels A2 & A3 using assembled Wood Dowels B and Camlocks A.
- 2): Assemble Top Panel A1 to Top Support Bar A5 using Screws F.

Step 5



Assemble Back Panel A4 to Side Panels A2 & A3, Top Panel A1 and Bottom Panel A7 using Screws G.

Step 6

H		8PCS
I		1SET

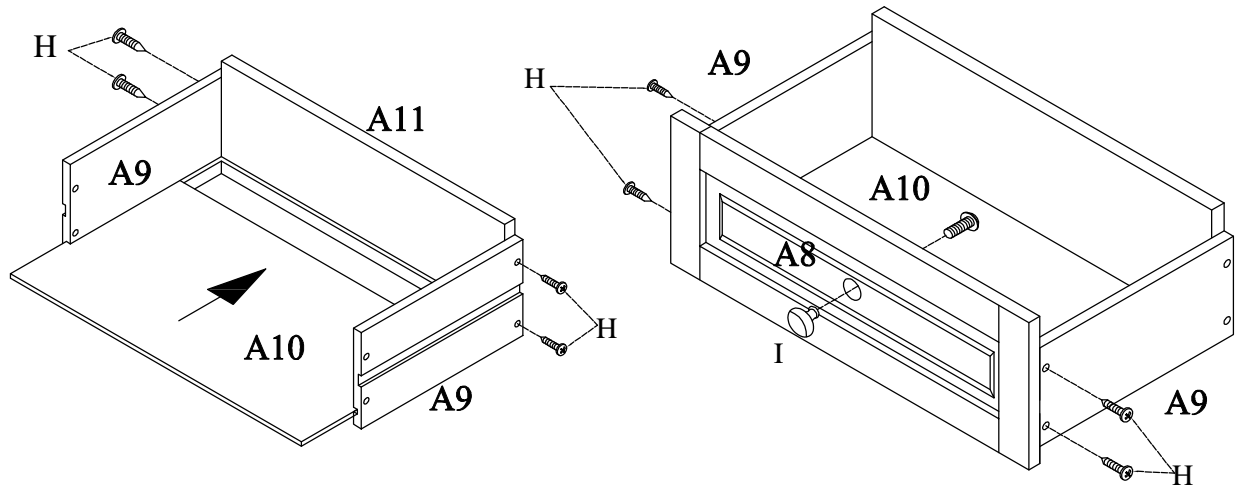

- 1): Assemble Drawer Side Panels A9 to Drawer Back Panel A11 using Screws H.
- 2): Insert Drawer Bottom Panel A10 into grooves on Drawer Side Panels A9 and Drawer Back Panel A11.
- 3): Assemble Drawer Front Panel A8 to Drawer Side Panels A9 using Screws H.
- 4): Attach Knob I to Drawer Front Panel A8 with included bolt.

Step 7

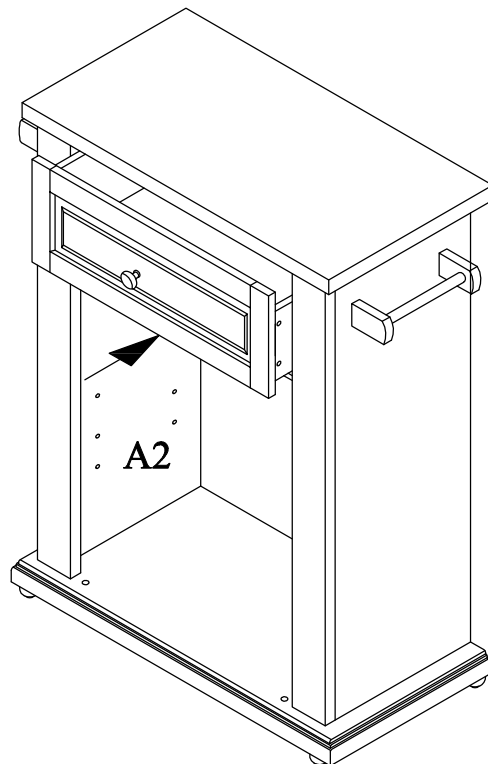

Insert the drawer as shown above.

Step 8

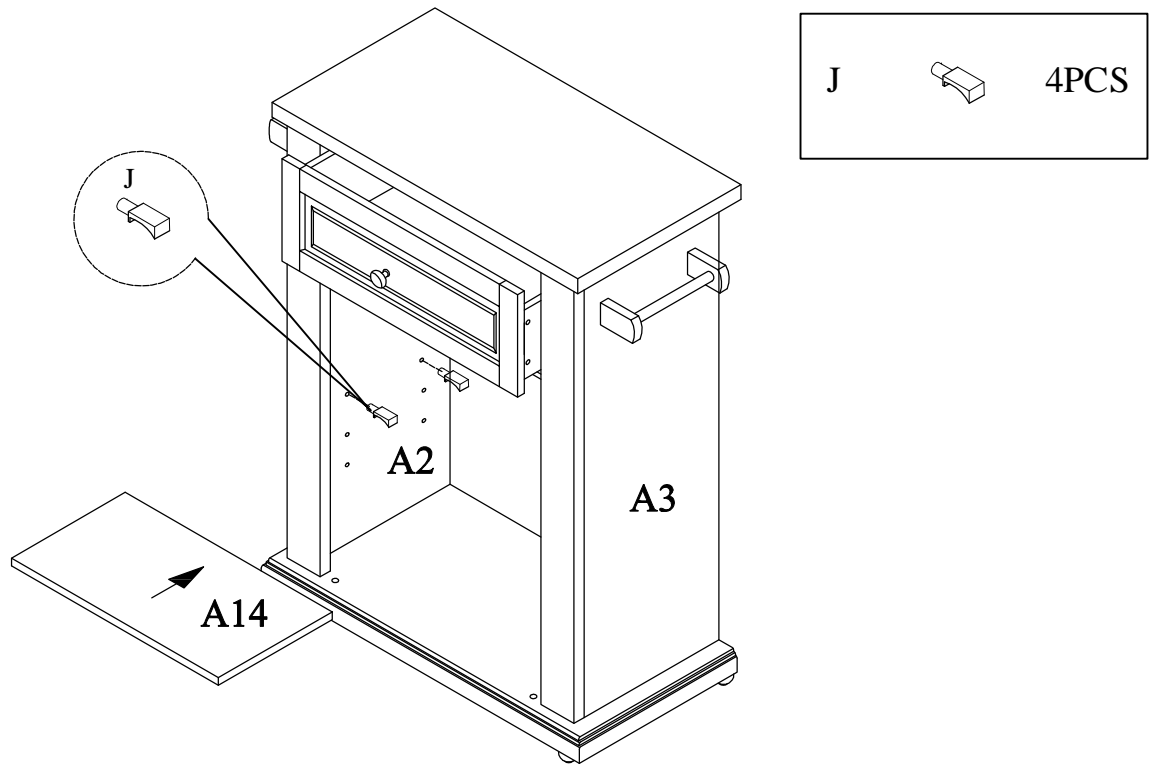

Insert Shelf Supports J into Side Panels A2 & A3 , then put Adjustable Shelf A14 onto Shelf Supports J.

Step 10

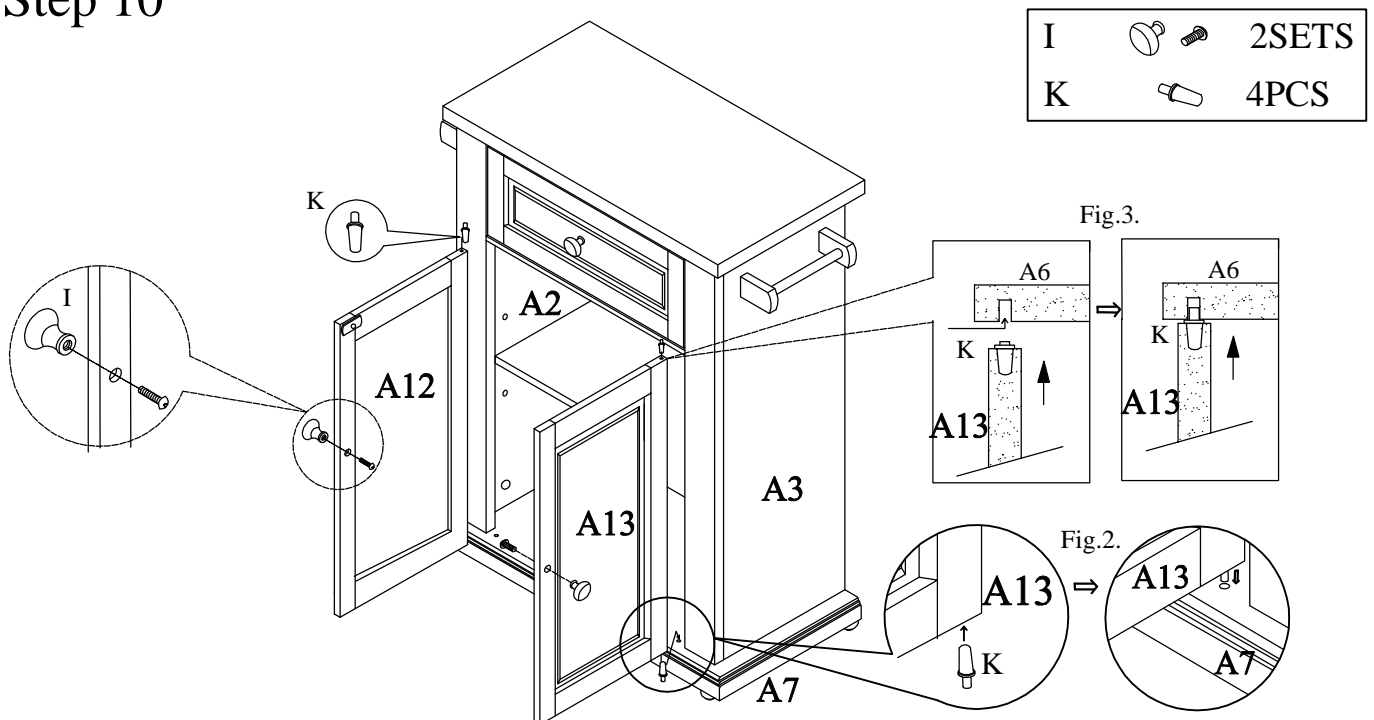

- 1): Insert Pin K into the hole on the bottom of Right Door A13, Then connect Right Door A13 to Bottom Panel A7 as below Fig.2. Insert Pin K into to hole on the top of Right Door A13, then press down Pin K see Fig.3. and hold the door panel carefully into the cabinet with the upper pin popping up into the hole of Top Support Bar A6.
- 2): Repeat the above step to assemble Left Door A12.
- 3): Assemble Knobs I to Doors A12 & A13 with included bolts.

Step 11

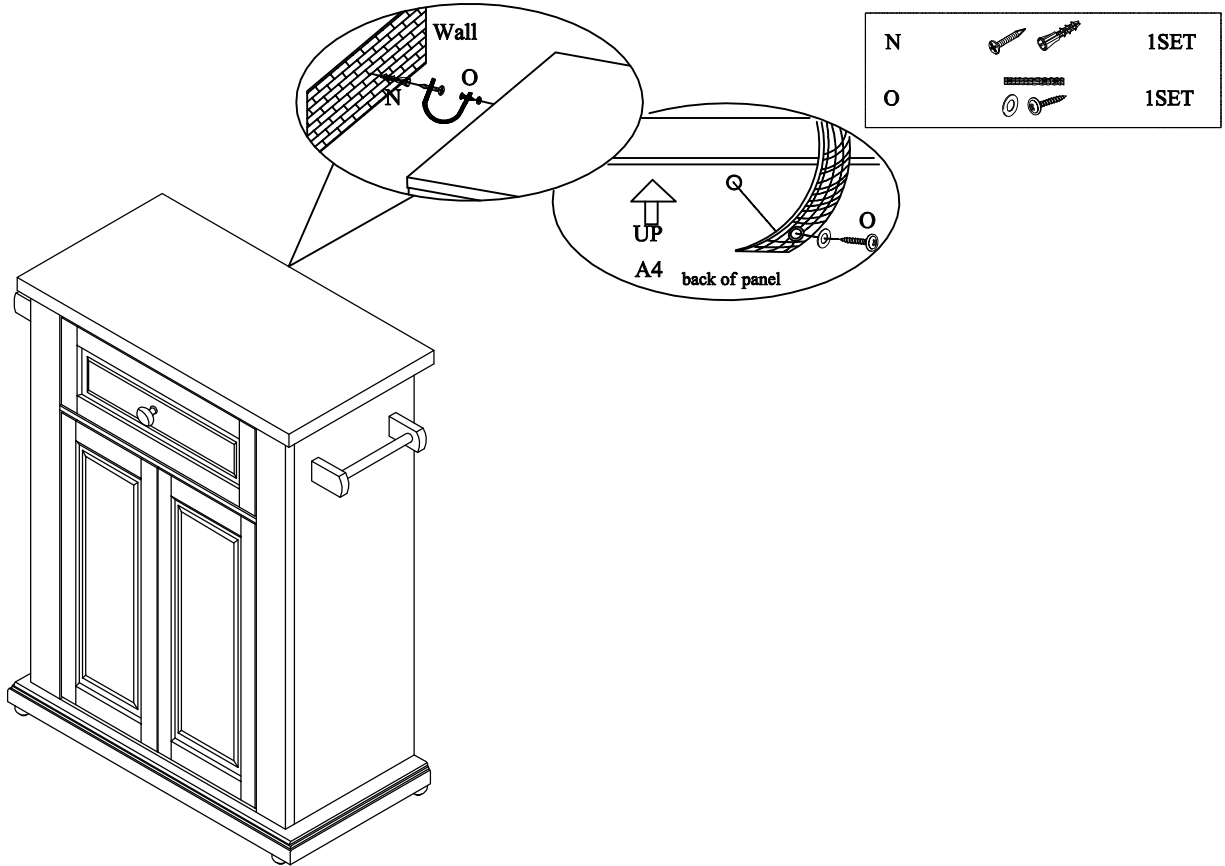

For your safety, please attached this unit to the wall by Anchor with Screw N and Anti-tip Kit O.

APPENDIX: Dimension of Hardwares in this AI.

<p>A</p> <p>1-1/8" L Dia: 1/4"</p> <p>Cam-bolt</p>	<p>Dia: 9/16" 3/8"</p> <p>Cam-Lock</p>	<p>B</p> <p>1-1/4" L Dia: 1/4"</p> <p>Wood Dowel</p>	<p>C</p> <p>9/16" L Dia: 1/8"</p> <p>Screw</p>
<p>D</p> <p>1/2" L Dia: 1/8"</p> <p>Screw</p>	<p>E</p> <p>1-3/16" L Dia: 1/4"</p> <p>Bolt</p>	<p>F&H</p> <p>1" L Dia: 1/6"</p> <p>Screw</p>	<p>G</p> <p>1/2" L Dia: 1/8"</p> <p>Screw</p>
<p>I</p> <p>5/8" L Dia: 5/32"</p> <p>Bolt</p>	<p>L</p> <p>3/8" L Dia: 1/4"</p> <p>Nut</p>	<p>N</p> <p>1-3/8" L Dia: 1/6"</p> <p>Screw</p>	<p>O</p> <p>9/16" L Dia: 1/8"</p> <p>Screw</p>