

PORTABLE BRAZILIAN HAMMOCK STAND UN9HS





Save these instructions for future reference.

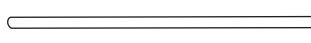

400
pounds
181.4 kg
Weight Capacity

WARNING: Failure to read and follow instructions and safety warnings could result in serious injury or damage to property.

Inspect packaging to ensure all parts are accounted for before disposing of packing materials.

No.	PARTS	QTY.
A	 Upright Tube (L/R)	2
B	 Crossbar	1
C	 Leg	2
D	 Hook Bolt Set	2
E	 Threaded Knob	5
F	 Carrying Case	1

WARNING
CHOKING HAZARD — This item contains small parts that can be swallowed. Keep children away during assembly.

CAUTION
This hammock stand is not designed for use as a swing. Bouncing, swinging, or any other significant movement while in use may result in serious injury.
This stand must be used on a level, stable surface. Make sure all hardware and connection points are securely tightened before every use.

ASSEMBLY

! Carefully read all assembly steps, care instructions, and safety information before using this product. **!**

Save these instructions for future reference.

Assemble components on a soft, clean surface to avoid scratching/damaging the finish.

When choosing a location for your hammock stand, select a smooth, level surface.

Do not install on dangerous terrain or objects such as slopes, on rocks, or in bodies of water.

STEP 1

B: 1 C: 2 E: 3

- Install one Threaded Knob (E) into the center of Crossbar (B).
- Slide two Legs (C) into Crossbar (B).
- Align the mounting holes and securely fasten each leg to the crossbar using one Threaded Knob (E).

NOTE: Installation of the threaded knob into the center of the crossbar is essential for achieving the maximum weight capacity. If the knob is not installed, the crossbar could bend and break the stand.

STEP 2

A: 2 E: 2

- Slide to Upright Tube (A) onto the legs.
- Align the mounting holes and securely fasten each upright tube using Threaded Knobs (E).

STEP 3

D: 2

- Ensuring the hook faces downward, securely install one Hook Bolt Set (D) on the outside of each upright, as shown.

IMPORTANT: The illustration is for reference only. Installation of the hooks will vary by hammock size. Adjust hooks as needed.

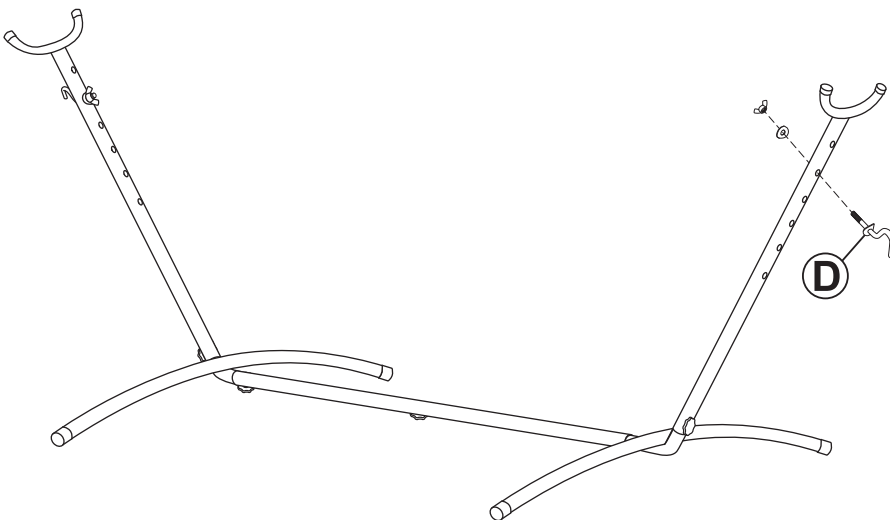
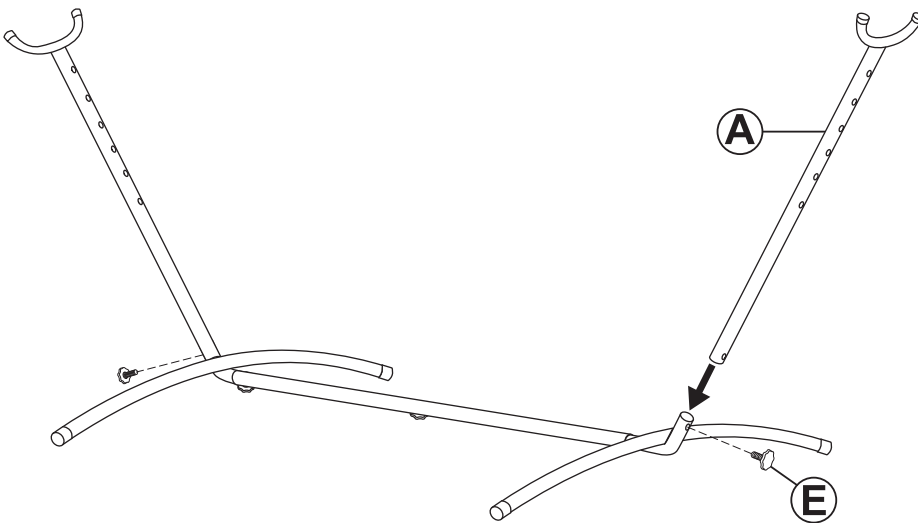
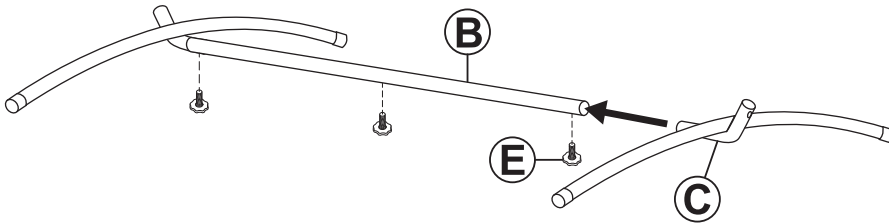

HANGING YOUR HAMMOCK (hammock not included)

! IMPORTANT !

This portable hammock stand accommodates **most** Brazilian-style hammocks that are between 10' and 12.5' in length from ring to ring.

Always leave some slack in the fabric when hanging your hammock.

The center of the hammock should be at a height where the user can enter and exit the hammock safely.

Always enter and exit hammocks slowly; moving too quickly can cause the hammock and/or stand to tip over.

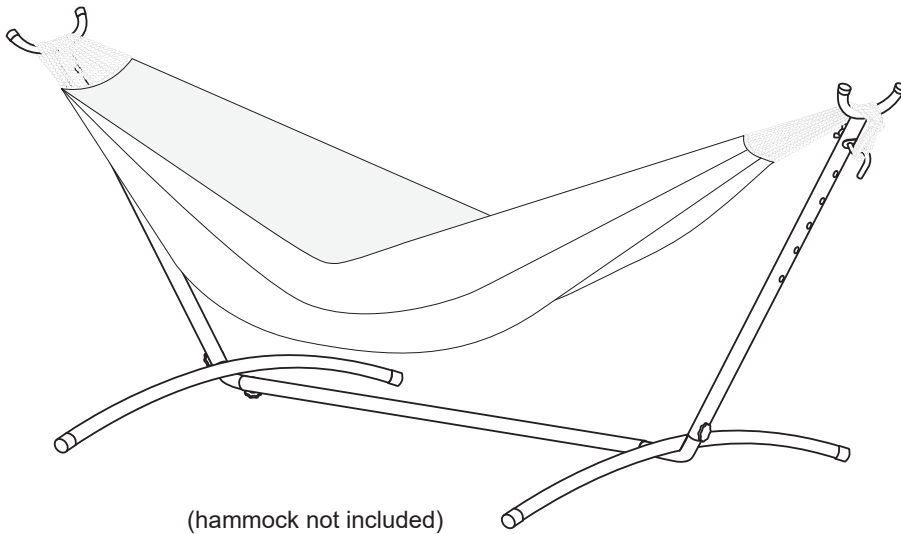

ADJUSTING HAMMOCK HEIGHT

(hammock not included)

Install the hooks to the height that best suits your Brazilian hammock.

The hammock should have a slight curve when first hung. There should be enough slack to enter and exit the hammock safely, but it must also be tight enough to accommodate the user's weight.

Lay the ropes of your Brazilian hammock over the top of the uprights and affix the rings to the hooks.

The fabric and ropes stretch over time; adjust the height as needed.

Always enter and exit the hammock in the middle. Do not use any hammock that hangs past the base legs.

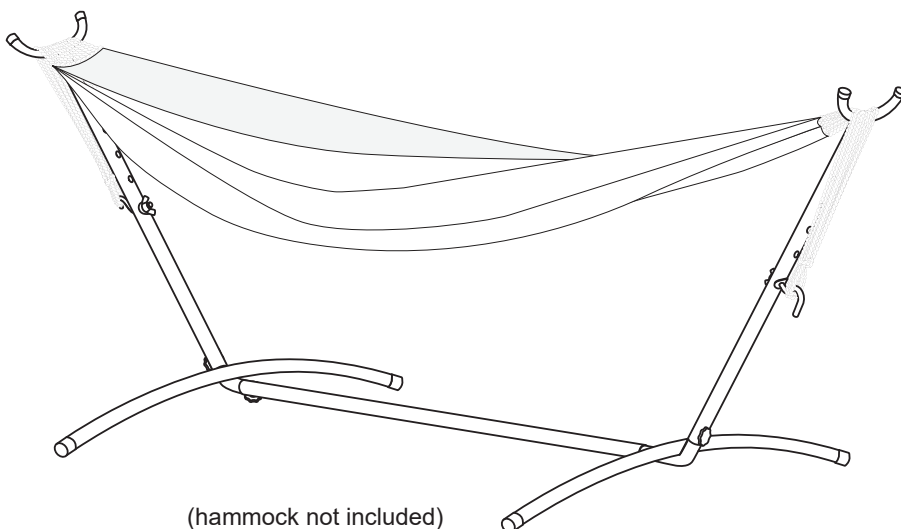

BEFORE USE

- Ensure all components and hardware are securely fastened.
- Only use on a flat, level surface.
- Carefully read all use, care, and safety information to ensure the stand is used safely.

GENERAL USE & CARE



WARNING: Do not use if parts are missing, worn, or damaged.



WARNING: Never leave a hammock hanging on this stand while it is not in use.



WARNING: Do not allow children to use this product without constant adult supervision.



WARNING: Always keep weight centered over the base when using this product.

SAFE USE: Follow all safety statements and warnings. Always move slowly when getting in and out of any hammock. This stand could cause serious injury, including, but not limited to, the stand tipping over if user(s) stand up in, swing, bounce, jump, or perform any other excessive movement while using a hammock.

CHILDREN: This stand is only to be used by adults and person(s) with developed motor skills who also understand the potential dangers if misused. Supervise children at all times. Never allow small or young children to enter or exit a hammock without adult assistance. Never allow or encourage children to sleep or play in a hammock. Always teach and practice safe hammock use, with and without a hammock stand.

INSPECTION: Frequently check hardware to ensure it remains securely fastened; tighten loose hardware as needed. Do not use the stand if parts are missing, broken, damaged, or worn. Don't forget that it is also important to inspect your hammock (not included) before every use.

COVER AND STORE: Protect your investment by covering or storing this stand when not in use. Avoid long-term exposure to precipitation and high-moisture areas. Covering the stand will protect it from damages caused by water and sunlight. Store in a cool, dry location.

CLEANING: Wipe surfaces with a soft cloth and warm water. Dry the stand after cleaning to prevent rust.

SCRATCHES: The powder coating on the stand is tough and durable, but even under normal use, some scratching is inevitable. To avoid excessive rust, wipe scratched areas as needed to remove moisture.

TROUBLESHOOTING

The stand seems unstable.

- If you are unfamiliar with using a hammock stand, it can leave you feeling uneasy; take some time to get used to it. Always enter and exit your hammock slowly. Swinging or aggressive movement can easily make the stand tip over and/or cause the metal to bend.
- Make sure it is on a flat, level surface.
- Ensure all components are assembled correctly and hardware is securely tightened.

My hammock hangs very low to the ground.

- Adjust the hooks on the uprights to a lower mounting hole. See *Adjusting Hammock Height*, page 3.
- Your hammock may be too long. This stand will accommodate most Brazilian hammocks 10' to 12.5' in length (rope lengths must be included when measuring).

Any modification to the product or failure to follow recommended care will void the product warranty.

WARNING!

Manufacturer and seller expressly disclaim any and all liability from personal injury, property damage or loss, whether direct or indirect, or incidental, resulting from the incorrect attachment, improper use, inadequate maintenance, or neglect of this product.