

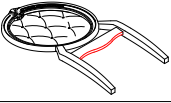

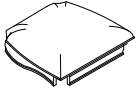





ASSEMBLY INSTRUCTION

MODEL: #66922 SIDE CHAIR

Thank you for purchasing this quality product. Be sure to check all packing material carefully for small part which may have come loose inside the carton during shipment. Separate, identify and count all parts and metal hardware. Compare with part list to be sure all parts are present. If any part(s) are missing or damaged, please contact your local furniture dealer. For efficient and speedy service, please indicate the model number and code letter of part(s) needed.

*** Do not fully tighten screws until fully assembled ***

PARTS LIST			
NO	DESCRIPTION	SKETCH	QTY
A	BACK FRAME		1 PC
B	SEAT CUSHION W/FRAME		1 PC
C	FRONT LEG		2 PCS

HARDWARE LIST			
NO	DESCRIPTION	SKETCH	QTY
1	ALLEN WRENCH (L57 * 4MM)		1 PC
2	BOLT (Ø5/16 " * 2-1/4 ")		4 PCS
3	BOLT (Ø5/16 " * 3-1/4 ")		4 PCS
4	BOLT (Ø5/16 " * 1-3/4 ")		2 PCS
5	LOCK WASHER (Ø5/16"*13*1.2)		10 PCS
6	FLAT WASHER (Ø5/16"*19*1.8)		10 PCS

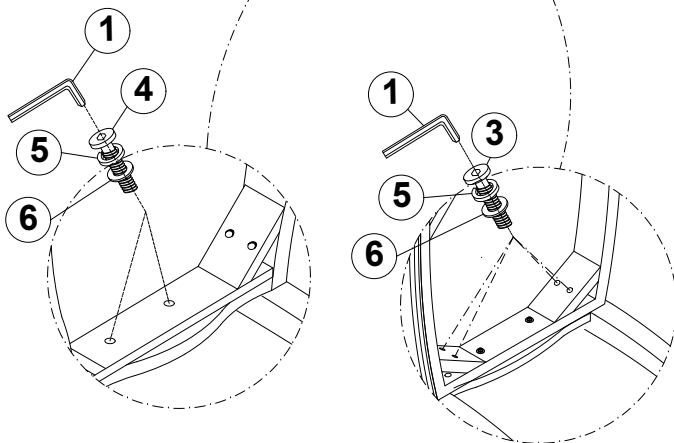
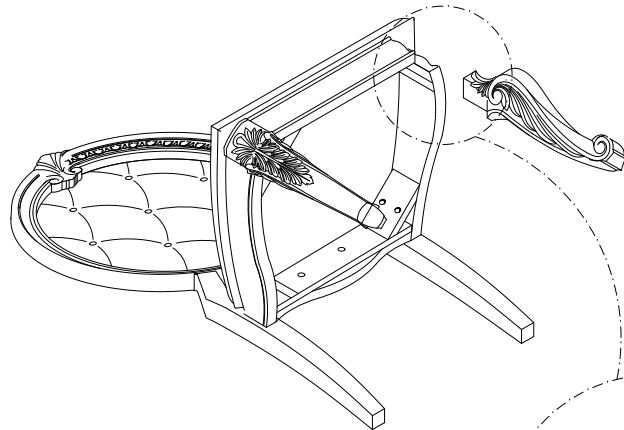
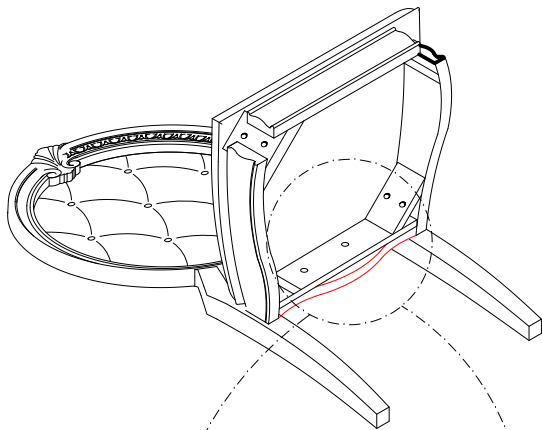

STEP 1

STEP 2

STEP 3

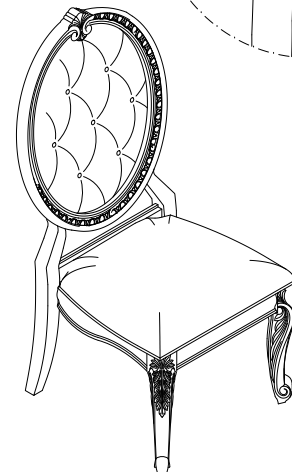
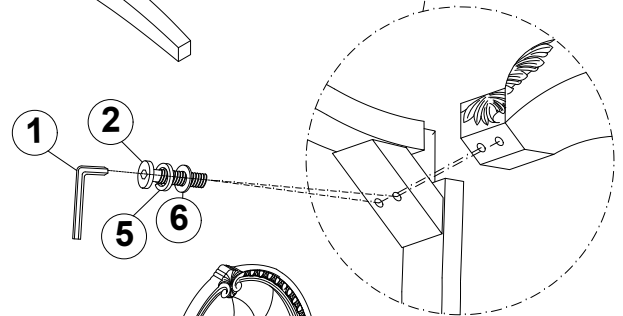

COMPLETED

Made in Viet Nam