



SPECIFICATIONS

COS-DFR486G Dual Fuel Range



| | |
|-----------------------|---|
| Size | 48 Inch / 5.8 cu. ft. Capacity |
| Fuel | Dual Fuel |
| Installation | Freestanding / Slide-In |
| Controls | Full Metal Knobs |
| Oven | Turbo True European (Main Oven) |
| Material | 304-Grade Stainless Steel |
| Electrical | 208 / 240 Volts, 29 / 33 Amps |
| Racks | 2 Racks, 5 Positions (Per Oven) |
| Oven Functions | Bake, Broil, Turbo Bake, Convection Bake, Convection Broil |
| Burners | <ul style="list-style-type: none">• Dual Ring / 18,000 BTU (x2)• Rapid / 13,000 BTU• Semi-Rapid / 8,500 BTU (x2)• Auxiliary / 4,200 BTU• Griddle / 13,000 BTU |

COS-DFR486G

Cosmo's COS-DFR486G Dual Fuel Range sets a standard for professional-style ranges. Cook a variety of different foods using the 6 Italian-made sealed burner gas cooktop with griddle and 5.8 cu. ft. electric double oven with Turbo True European Convection.

Features

- Designed for freestanding or slide-in
- 6 sealed Italian-made gas burners & griddle
- Double electric ovens
- Main oven: 3.97 cu. ft. capacity with Turbo True European Convection
- Second oven: 1.87 cu. ft. capacity with standard bake
- Full metal, nickel-finished knobs
- Wok grate attachment



Griddle



Double Oven



Metal Knobs



See Page 2 for dimensions

For more information, please visit: www.cosmoappliances.com



DIMENSIONS

COS-DFR486G Dual Fuel Range

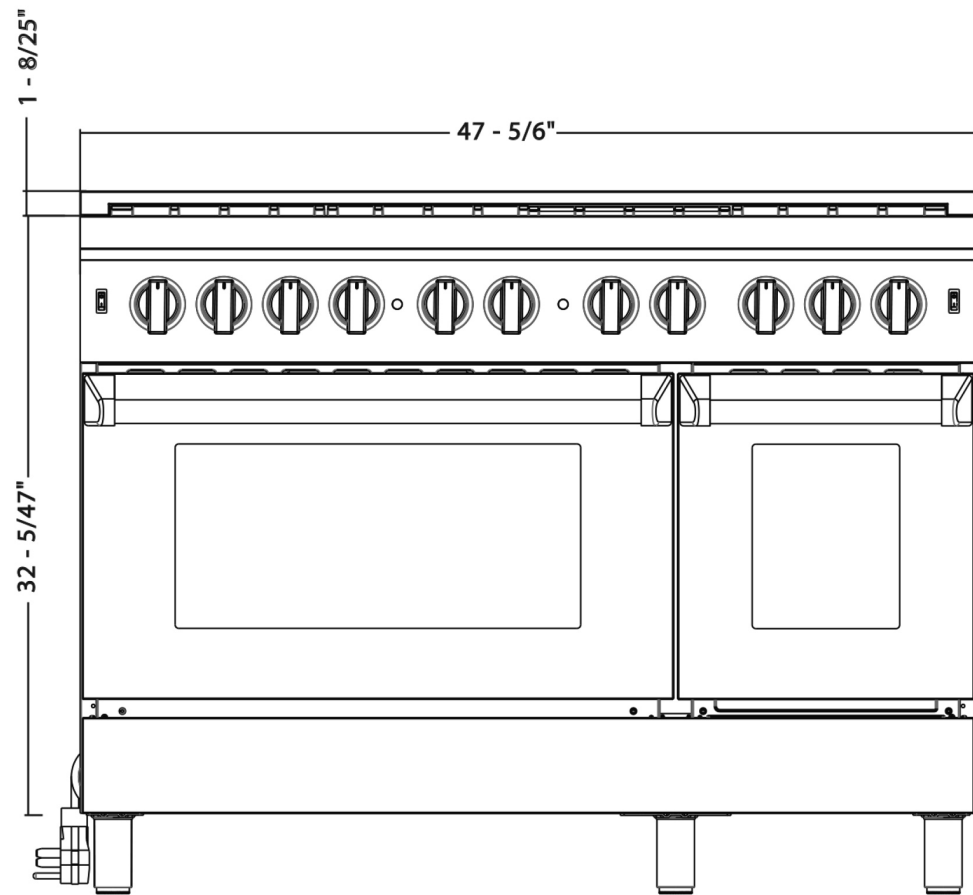

FRONT

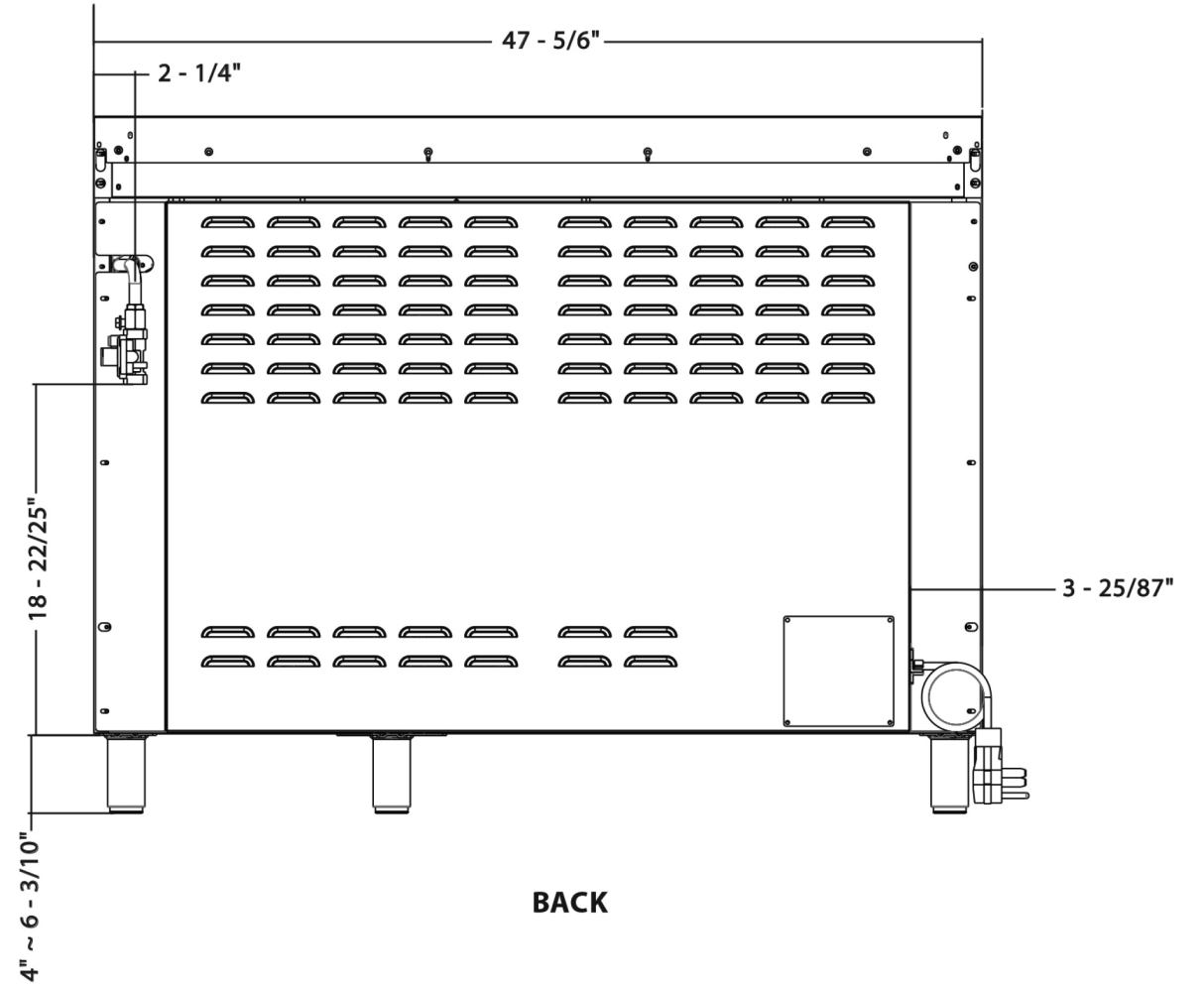

BACK

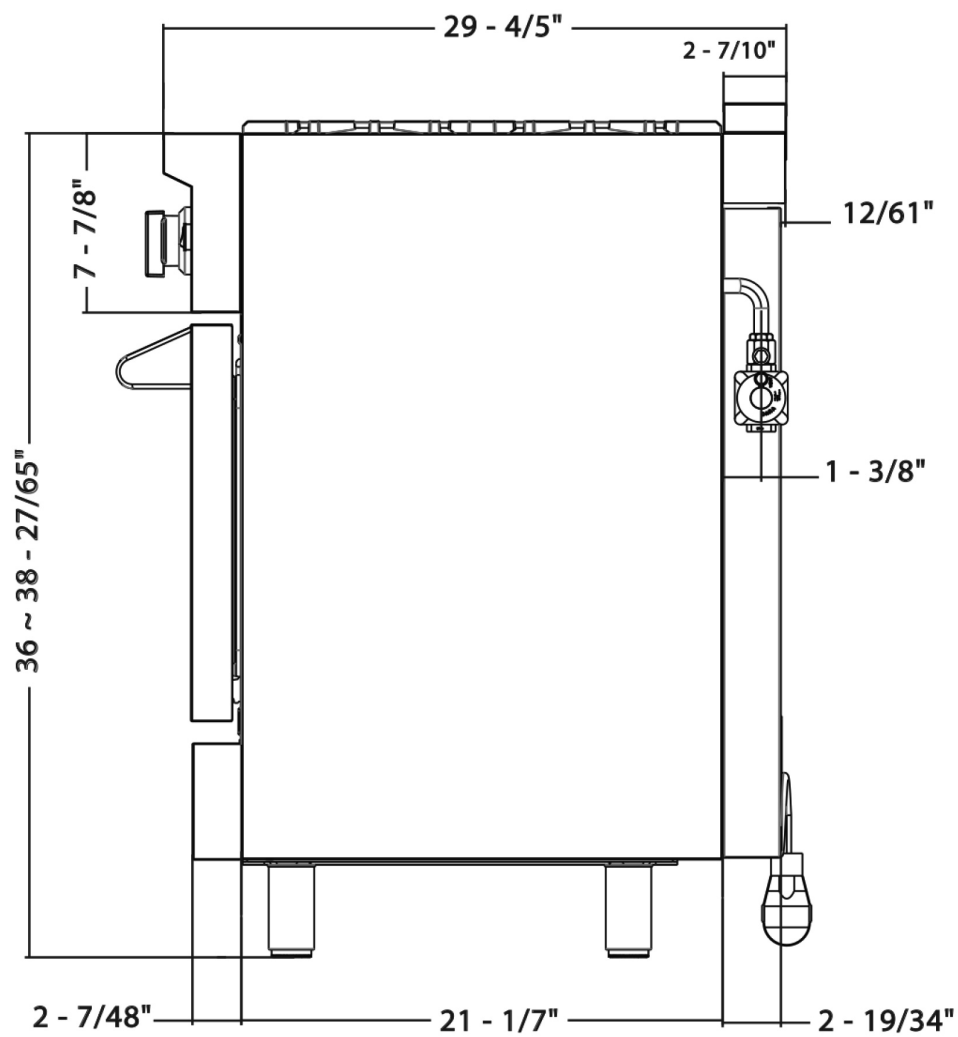

LEFT

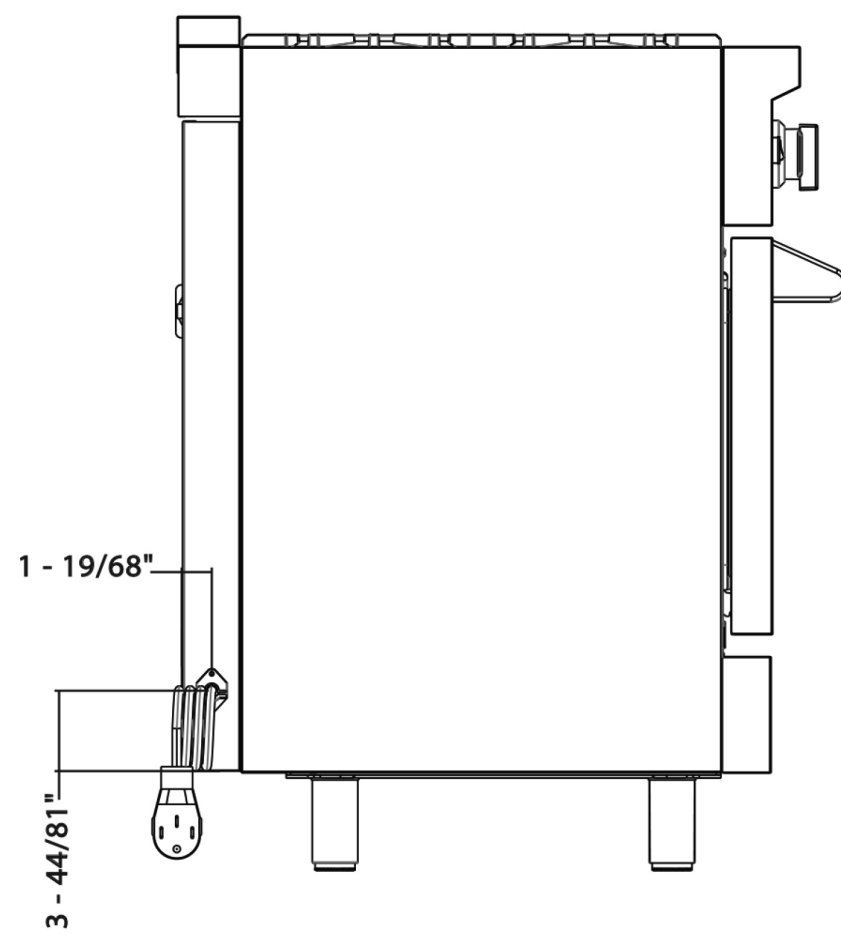

RIGHT

Dimensions (WxDxH): 47.8" x 29.8" x 36-38.4"