

installation instructions:

# METAL BRACKET

## SAFETY INSTRUCTIONS

Make sure to use the correct tools recommended.

Wear safety goggles.

Follow fixture, power tools, and paint manufacturers' instructions and users manuals.

Use common sense and follow good construction practices.

Consult a professional when installing brackets for load bearing applications.

## TOOL & MATERIAL CHECKLIST

- electric drill
- screws
- level
- pencil
- shims

## IMPORTANT INFO

- It is highly recommended that you paint/finish our steel brackets before you install them.
- Once installed, you can apply any necessary touchup paint/finish.
- Make sure that the surface and the back of the bracket are completely clean & dry before attempting installation.
- Measure and mark the location where the bracket is going to be installed and be sure that the bracket has a substructure with a minimum 3/4" thickness.

## INSTALL INSTRUCTIONS:

1. Paint or finish your bracket.
2. Be sure that the installation area is supported by a substructure with a minimum of 3/4" thickness.
3. Place the bracket in place, check that it is level, and mark its position with a pencil.
4. If the angle of your installation area and bracket do not match use shims to adjust the angle.
5. Fasten the bracket in place with screws and check that it is level.
6. Touch up the bracket with touch up paint as needed.

**Finishing Note:** Unfinished steel brackets will need to be finished before installation. Clean the bracket before painting. Once clean and dry, apply a metal compatible paint, letting the first coat dry completely before painting a final coat/s of paint. The paint should be completely dry before installing.

**Installation Note:** Weak substructure makes for a weak installation. Install in sturdy infrastructure for best results. We suggest spacing out the brackets no greater than 30" apart on a standard application. When manufacturing our metal brackets we attempt to make the angle break at 90 degrees every time, however the angle could be slightly off on occasion. If this happens, use a shim in the installation to bring the bracket to level. Shims can be used directly behind the backplate or you may need to shave the support stud to allow for a flush installation.

*Please note this installation document should not be considered a specific recommendation for every application. The particular support needs for each installation may vary and this document should be used as a guide that offers helpful considerations about the general installation of metal brackets.*

## EXAMPLE DIAGRAM:

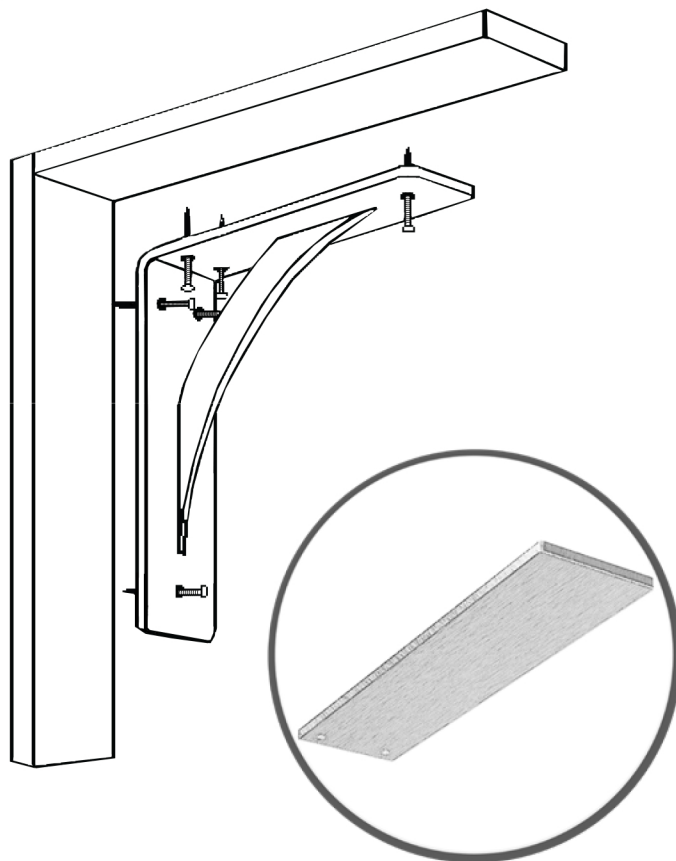

*Please note for hidden support brackets install these into a 2x4 board, and route out your cabinet 1/4" to fit the bracket.*

We Can Help. Call (866) 607-0453



**EKENA**  
MILLWORK

Industry leading manufacturer of urethane, PVC, wood, rustic, and metal millwork

[www.ekenamillwork.com](http://www.ekenamillwork.com)