

MANUAL DE MONTAGEM
ASSEMBLY INSTRUCTIONS
INSTRUCCIONES DE MONTAJE

COD BR: 18200
COD US: 19600

Sumário

Summary
Resumen

Introdução Introduction Introducción	2
Antes de começar Before starting Antes de comenzar	3
Evite acidentes Avoid accidents Evitar accidentes	3
Identificação das peças Identifying parts Identificación de las piezas	4
Dimensões e ferramentas Dimensions and tools Dimensiones y herramientas	4
Montagem do móvel Furniture assembly Montaje de la mueble	5

Introdução

Introduction
Introducción

Leia atentamente este manual e siga os passos indicados para uma perfeita montagem.
Read this manual and follow the steps for the perfect fit.
Lea este manual y siga los pasos para el ajuste perfecto.

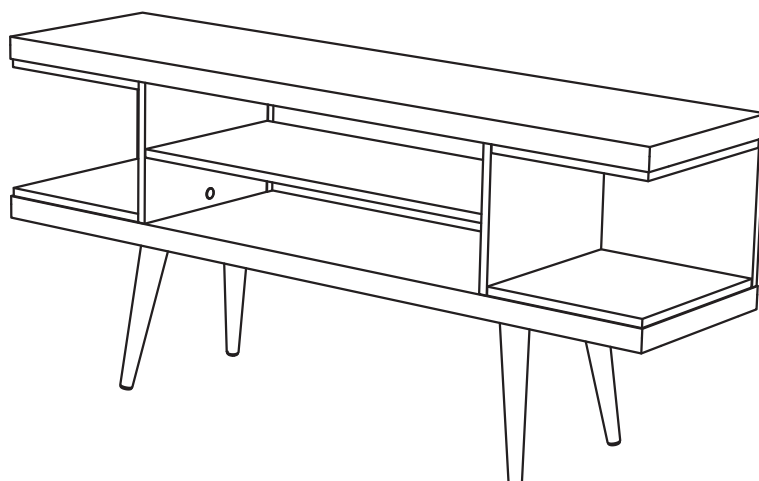

Antes de começar

Before starting

Antes de comenzar

Antes de começar a montagem prepare o ambiente, deixando-o completamente limpo e com bom espaço para iniciar o trabalho.

Prepare the room before starting the assembly, leaving it completely clean and the area in good condition to start the work.

Antes de comenzar el montaje preparar el ambiente, dejándolo completamente limpio y con buen espacio para comenzar el trabajo.

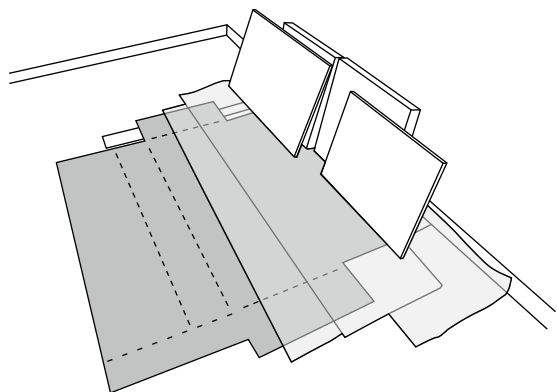

Utilize o papelão da própria embalagem, bem como a isomanta de proteção para separar e apoiar as peças retiradas das caixas.

Use the cardboard of the packaging and the foam sheets protection to separate and support the parts removed from the boxes.

Utilice el cartón de la embalaje y la espuma protectora para separar y apoyan las piezas desmontadas de las cajas.

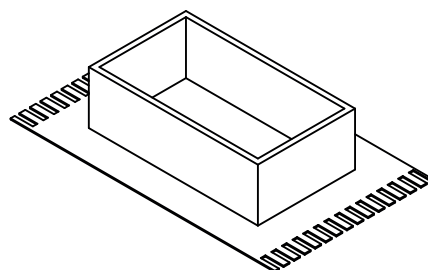

Forre a área de montagem com um cobertor ou tapete. Assim, você evita avarias nas peças durante o processo de montagem.

Cover the assembly area with a blanket or carpet to avoid damaging the parts during the assembly process.

Cubrir la zona de ensamble con una manta o alfombra. De este modo, se evitan daños en las piezas durante el proceso de montaje.

Evite acidentes

Avoid accidents

Prevenir accidentes

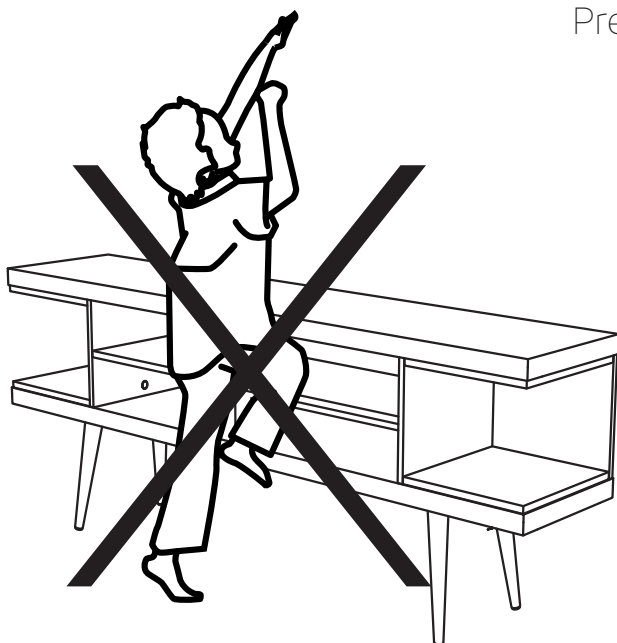

Não escale ou se apoie no móvel.

Do not climb or lean on the furniture.

No se suba ni se apoye en el mueble.

Para identificar o número da peça, verifique o verso da mesma, lá você encontra informações do lote de fabricação, código de identificação do produto e o número da peça.

To identify the part number, check its back. There you can find information from the production batch, product reference code and part number.

Para identificar el número de pieza, compruebe en la parte posterior de cada una, ahí también se puede encontrar información del número de lote de producción, el código de indentificación del producto y el número de la pieza.

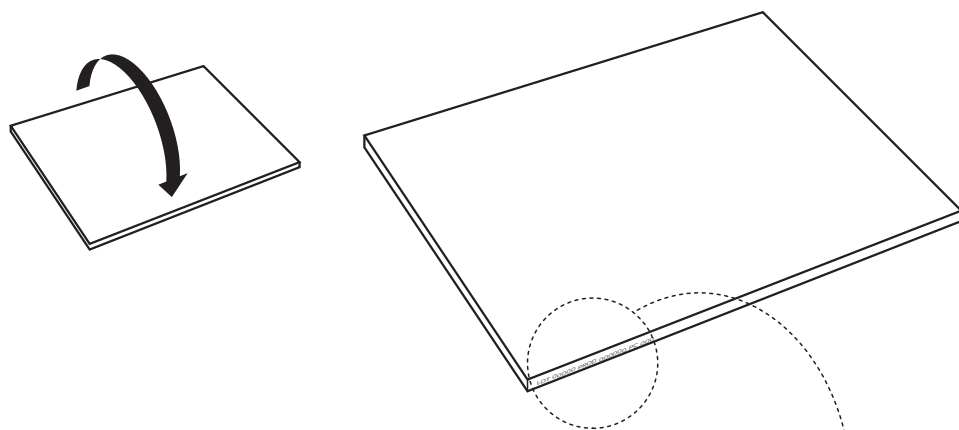

LOT 000000 | PRODUC 000000 | PC 000

Número do lote de fabricação do seu produto.

Manufacturing batch number of the product.

Numero de lote fabricación de su producto.

Número de identificação do seu produto.

Reference number of the product.

Numero de indentificación de su producto.

Número da peça.
Part number.
Número de pieza.

Dimensões e ferramentas

Dimensions and tools

Dimensiones y herramientas

Dimensões:

L: **1350** A: 610 P: 356 mm

Dimensions:

W: **53.15** H: 24.02 D:14.02 inches

Dimensiones:

L: **1350** A: 610 P: 356 mm

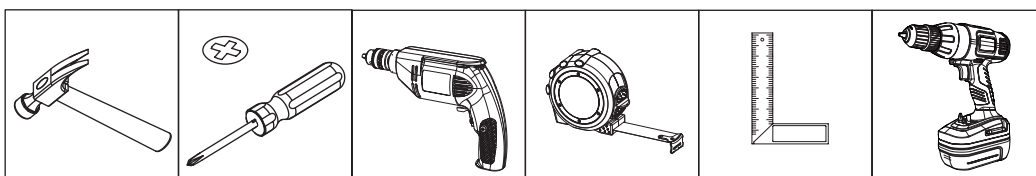
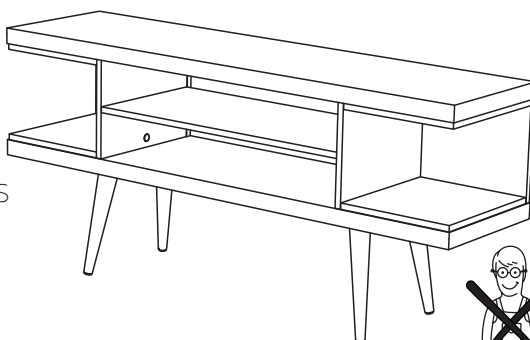

COD BR: 18200
 COD US: 19600

PEÇA	DESCRIÇÃO	QUANT.	CAIXA	PART	DESCRIPTION	QTY	BOX	PIEZA	DESCRIPCIÓN	CANTIDAD	CAJA
021	FUNDO	1	1	021	BACKPLATE	1	1	021	FONDO	1	1
022	BASE	1	1	022	BASE	1	1	022	BASE	1	1
023	TAMPO	1	1	023	TOP BOARD	1	1	023	CUBIERTA	1	1
024	PAINEL SUPERIOR NICHOS	2	1	024	NICHE TOP PANEL	2	1	024	PANEL SUPERIOR NICHOS	2	1
025	FUNDO NICHOS	2	1	025	NICHE BACK PANEL	2	1	025	FONDO NICHOS	2	1
026	NICHOS LATERAL	2	1	026	SIDE NICHE	2	1	026	NICHOS LATERAL	2	1
027	INFERIOR NICHOS	2	1	027	NICHE BOTTOM	2	1	027	NICHOS INFERIOR	2	1
028	DIVISÓRIA MAIOR	1	1	028	LONG DIVIDER	1	1	028	DIVISION MAYOR	1	1
050	PÉ	4	1	050	LEG	4	1	050	PATA	4	1

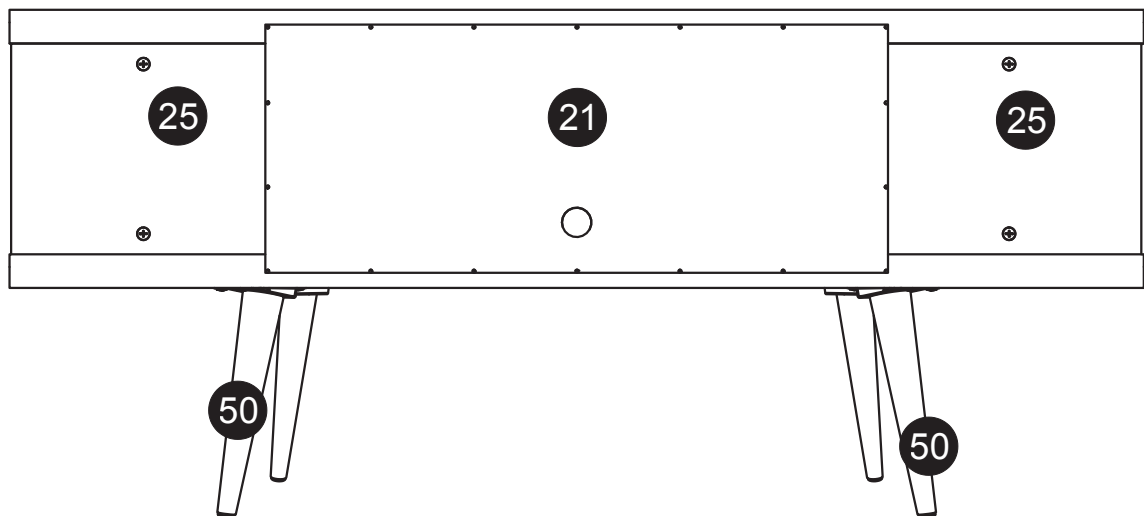
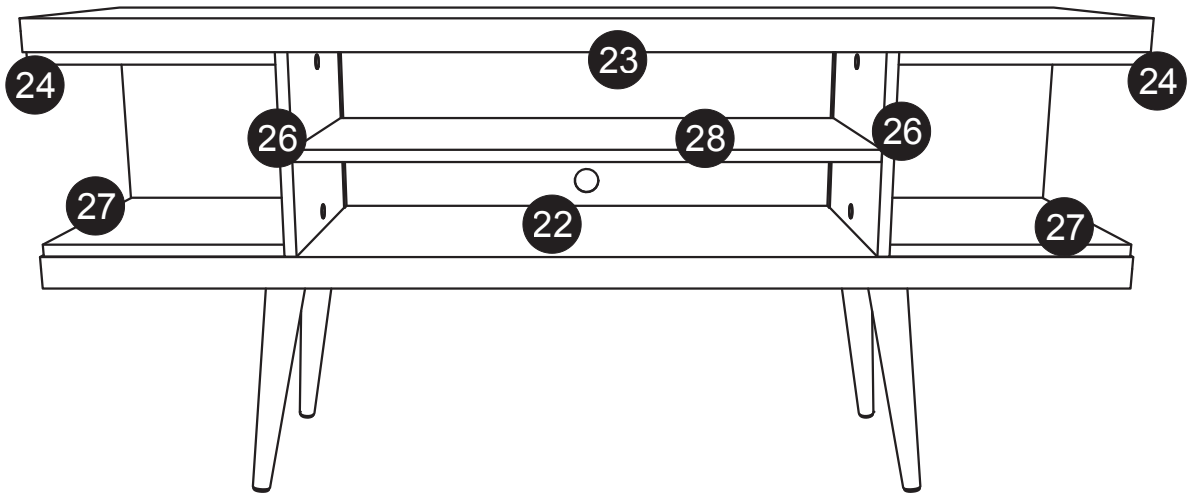

ADESIVO
STICKER
ADHESIVO

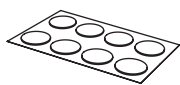

x 5



0494 x 11



1668 x 22



8471 x 4



0599 x 11

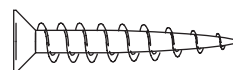

3706 x 9

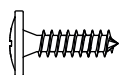

8056 x 18

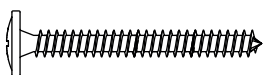

9333 x 10

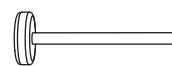

0357 x 20

A = 20KG - 44LB

B = 03KG - 6.61LB

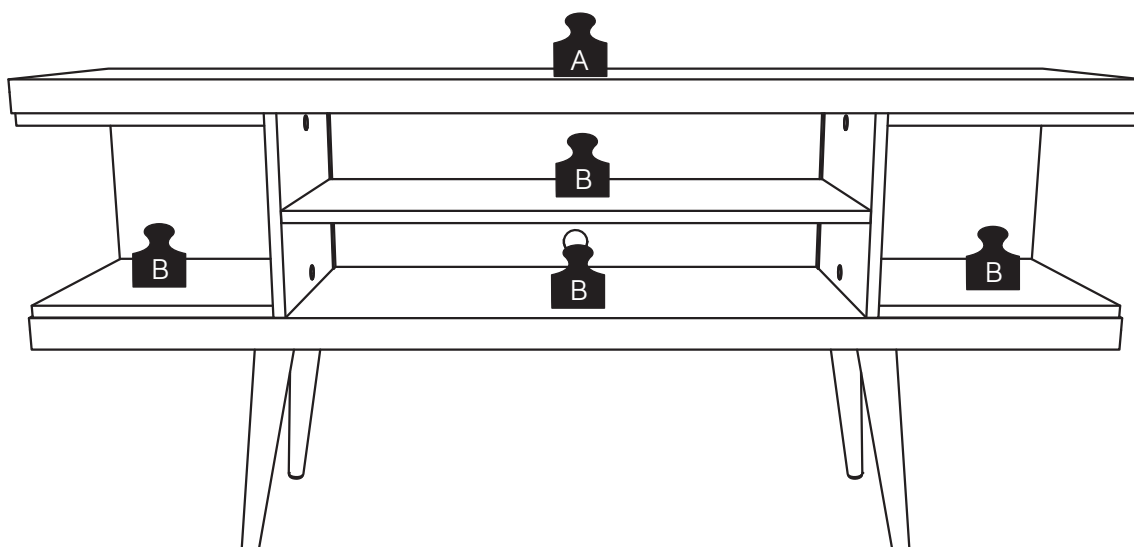

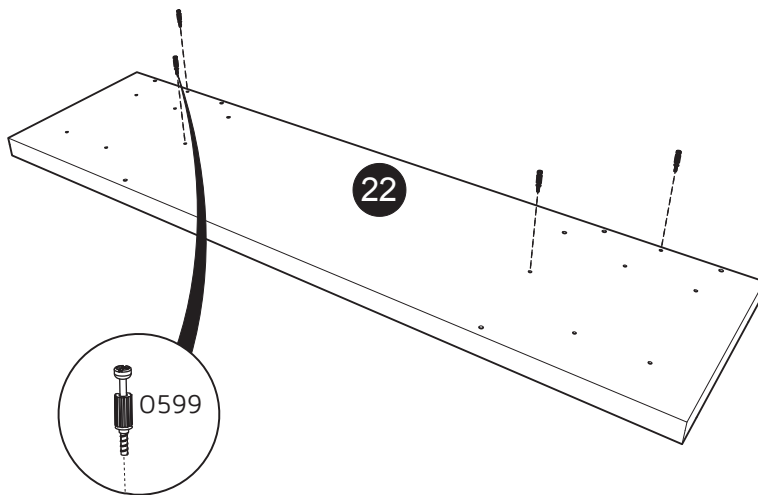

PASSO 01

Parafusar minifix 4x**0599**
na Base **22**.

STEP 01

Screw minifix 4x**0599**
on Base **22**.

PASO 01

Atornillar el minifix 4x**0599**
en la Base **22**.

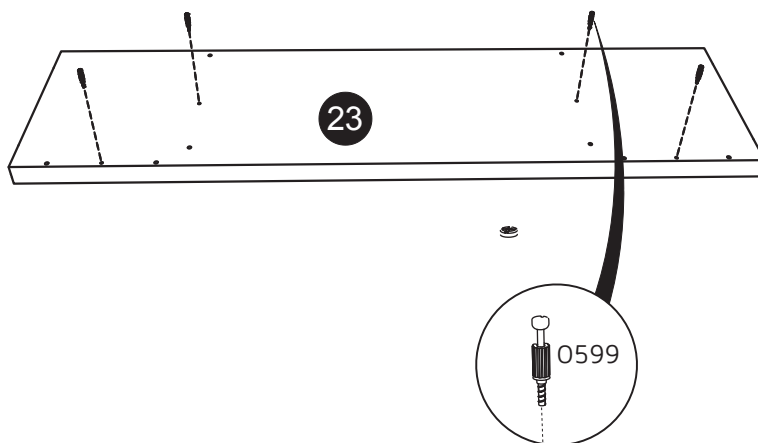

PASSO 02

Parafusar minifix 4x**0599**
na Tampo **23**.

STEP 02

Screw minifix 4x**0599**
on Top Board **23**.

PASO 02

Atornillar el minifix 4x**0599**
en la Cubierta **23**.

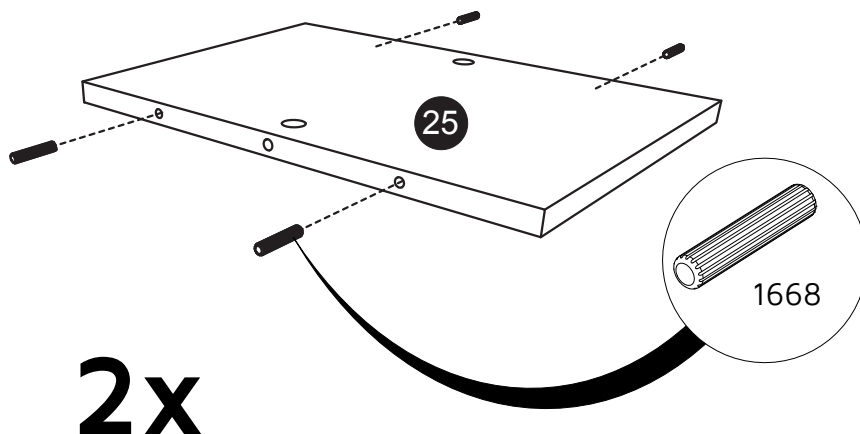

PASSO 03

Encaixar cavilhas 4x**1668**
na Fundo Nicho **25**.

STEP 03

Insert dowels 4x**1668**
on Niche Bottom **25**.

PASO 03

Clavijas de ajuste 4x**1668**
en Fondo Nicho **25**.

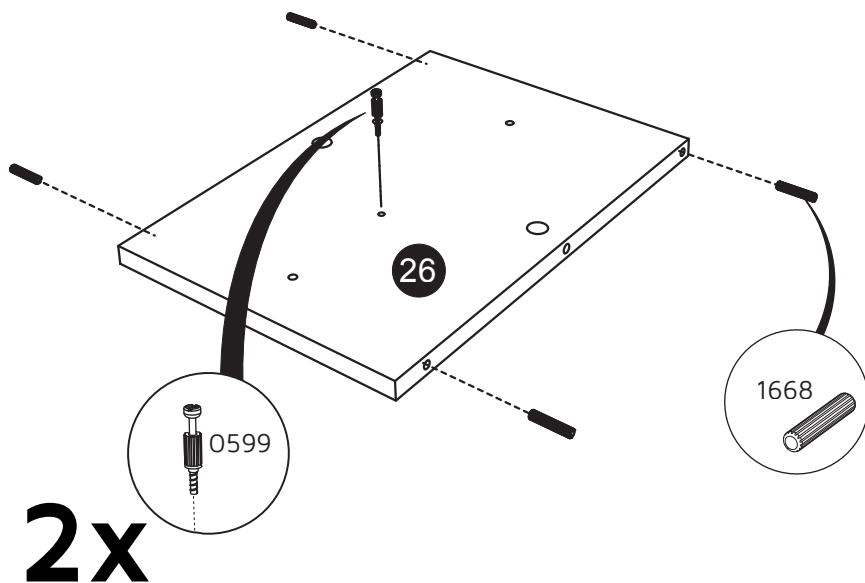

PASSO 04

Encaixar cavilhas 4x1668 e parafusar minifix 1x0599 na Nicho Lateral 26.

STEP 04

Insert dowels 4x1668 and screw minifix 1x0599 on Niche Side 26.

PASO 04

Clavijas de ajuste 4x1668 y atornillar el minifix 1x0599 en el Nicho Lateral 26.

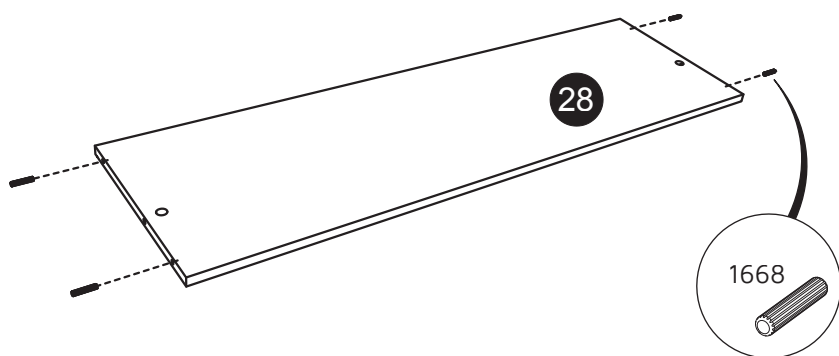

PASSO 05

Encaixar cavilhas 4x1668 na Divisoria Maior 28.

STEP 05

Insert dowels 4x1668 on Long Divider 28.

PASO 05

Clavijas de ajuste 4x1668 en la Division Mayor 28.

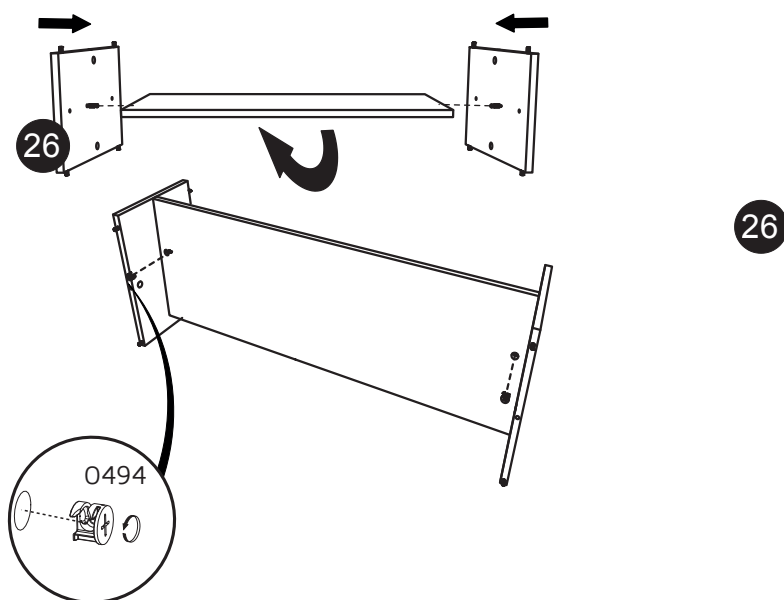

PASSO 06

Encaixar Laterais 26. Parafusar castanhas 2x0494.

STEP 06

Attach Sides 26. Screw nuts 2x0494.

PASO 06

Enganchar las Laterales 26. Atornillar las tuercas 2x0494.

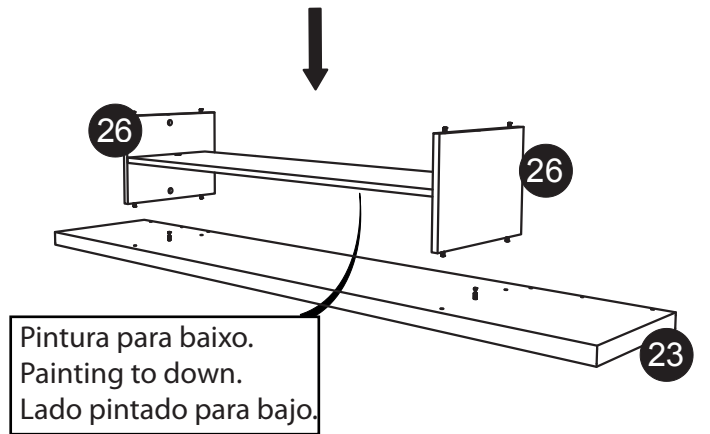

PASSO 07

Encaixar Laterais **26** no Tampo **23**.
Parafusar castanhas 2x**0494**
e colar **2** adesivos.

STEP 07

Attach Sides **26** to Top Board **23**.
Screw nuts 2x**0494** and place
2 stickers.

PASSO 07

Montar las Laterales **26** en la Cubierta **23**.
Atornillar las tuercas 2x**0494**
y pegar **2** adhesivos.

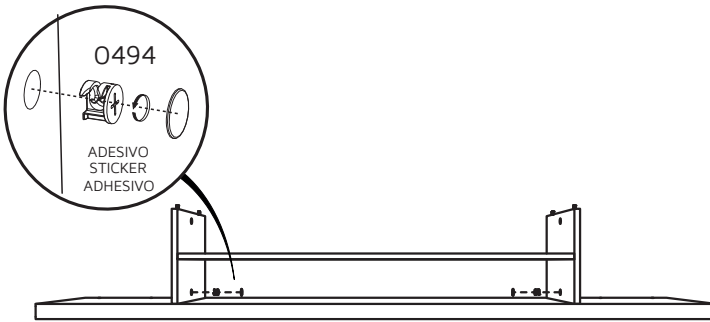

PASSO 08

Encaixar Fundo Nicho **25** no Tampo **23**.
Parafusar castanhas 2x**0494**.

STEP 08

Attach Niche Bottom **25** to Top Board **23**.
Screw nuts 2x**0494**.

PASSO 08

Montar el Fondo Nicho **25** en la Cubierta **22**.
Atornillar las tuercas 2x**0494**.

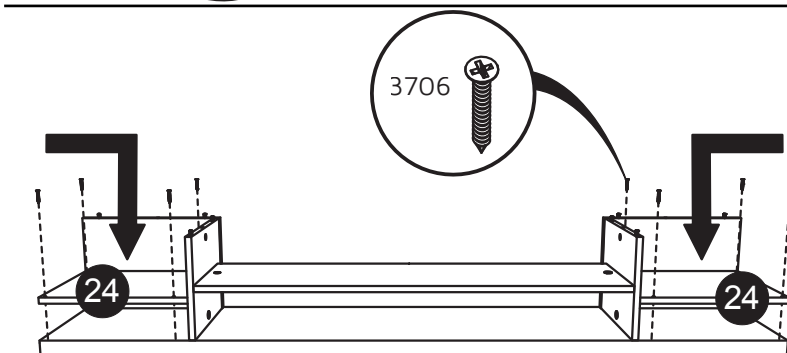
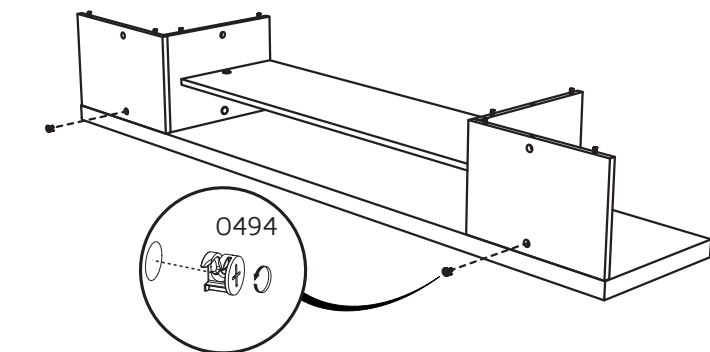

PASSO 09

Encaixar Panel Superior nicho **24**.
Parafusar 8x**3706**

STEP 09

Attach Niche Top **24**.
Screw 8x**3706**

PASSO 09

Montar el Panel Superior Nicho **24**.
Atornillar 8x**3706**.

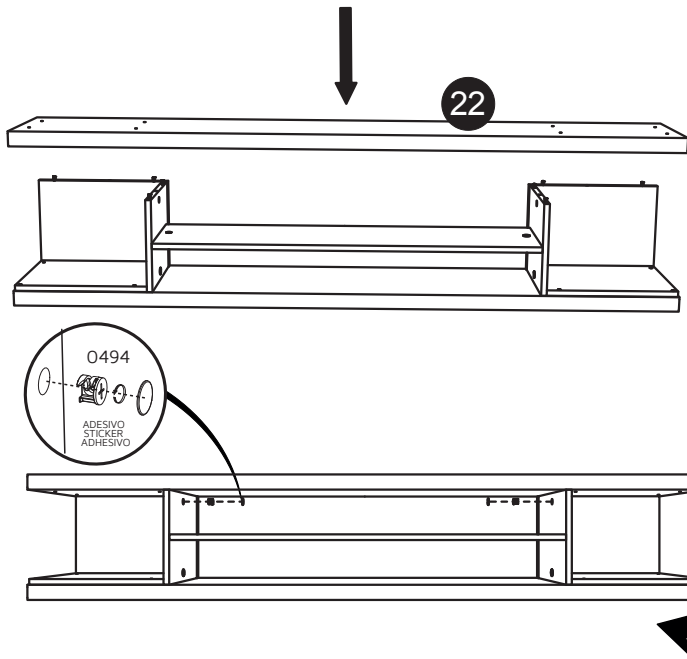

PASSO 10

Encaixar Base **22**. Parafusar castanhas 3x**0494** e colar **2** adesivos.

STEP 10

Attach Base **22**. Screw nuts 3x**0494** and place **2** stickers.

PASO 10

Montar Base **22**. Atornillar las tuercas 3x**0494** y pegar **2** adhesivos.

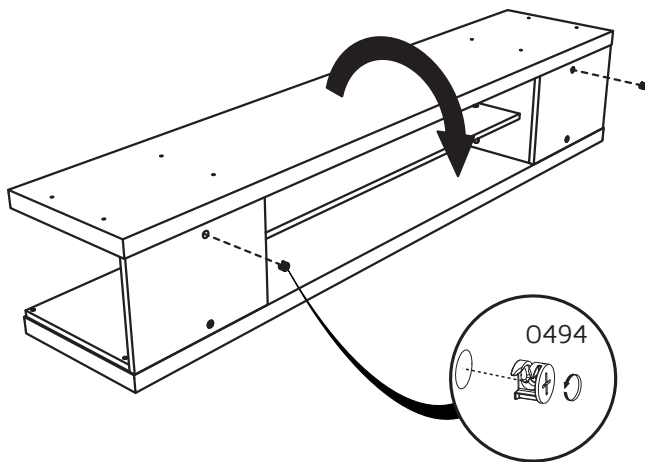

PASSO 10.1

Parafusar 2x**0494**.

STEP 10.1

Screw nuts 2x**0494**.

PASO 10.1

Atornillar las tuercas 2x**0494**.

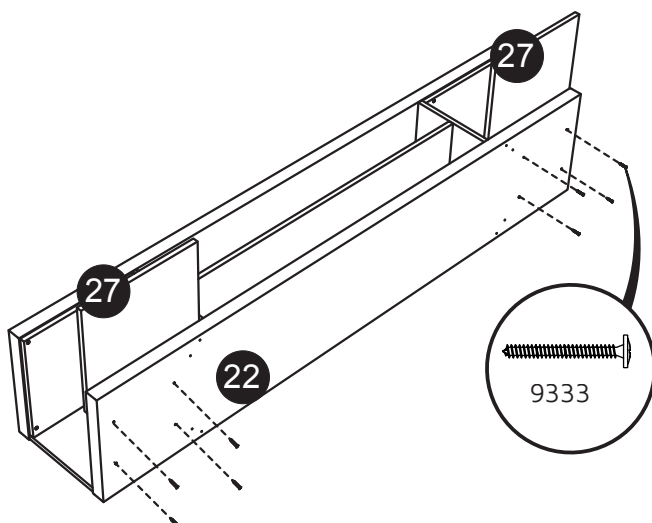

PASSO 11

Encaixar Inferior Nicho **27** na Base **22**. Parafusar 8x**9333**.

STEP 11

Attach Bottom Niche **27** to Base **22**. Screw 8x**9333**.

PASO 11

Montar el Fondo Nicho **27** en la Base **22**. Atornillar 8x**9333**.

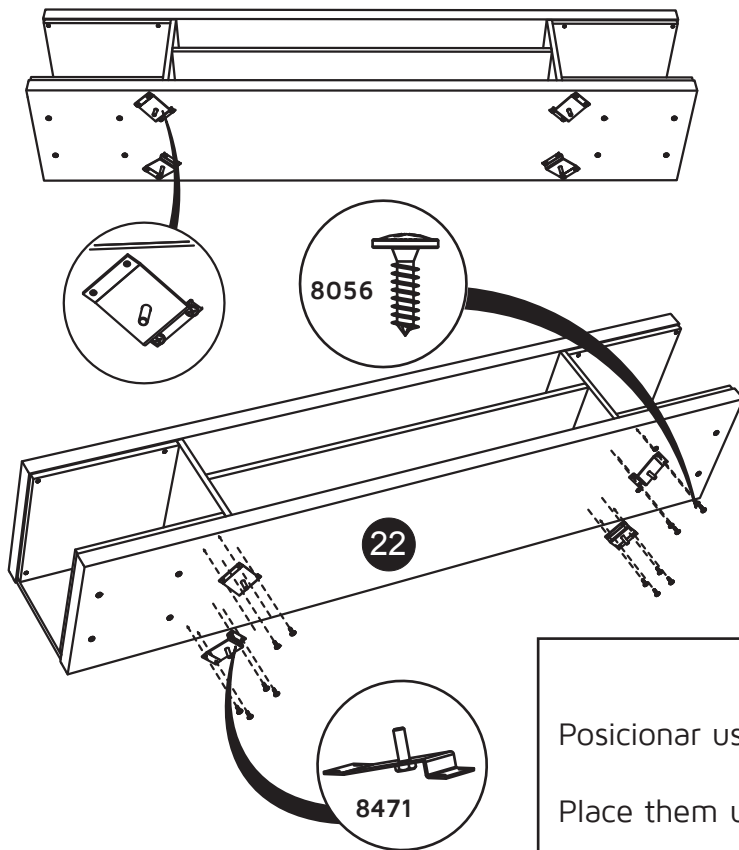

PASSO 12

Encaixar 4x8471 e parafusar 16x8056 na Base 22.

STEP 12

Attach 4x8471 and screw 16x8056 on Base 22.

PASO 12

Montar 4x8471 y atornillar el 16x8056 en Base 22.

Posicionar usando furo guia.
Place them using pilot hole.
Posicionar usando agujero piloto.

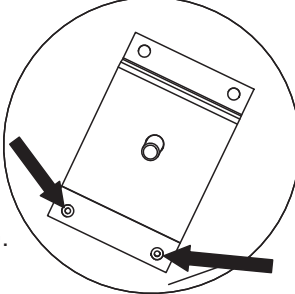

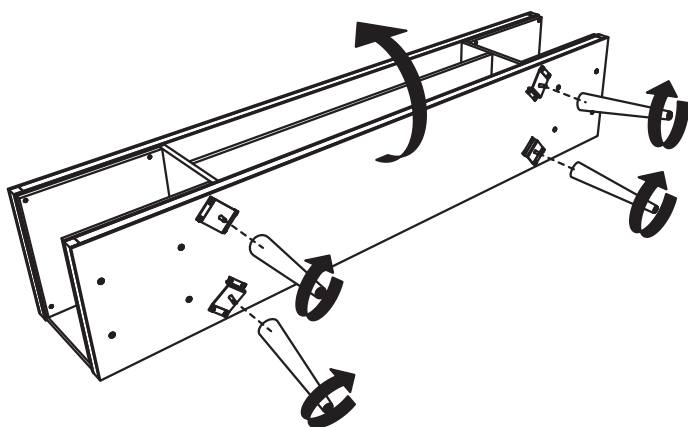

PASSO 13

Encaixar e rosquear 4x Pes 50 na Base 22.

STEP 13

Attach and screw 4x Leg 50 in the Base 22.

PASO 13

Montar y atornillar 4x Pata 50 en Base 22.

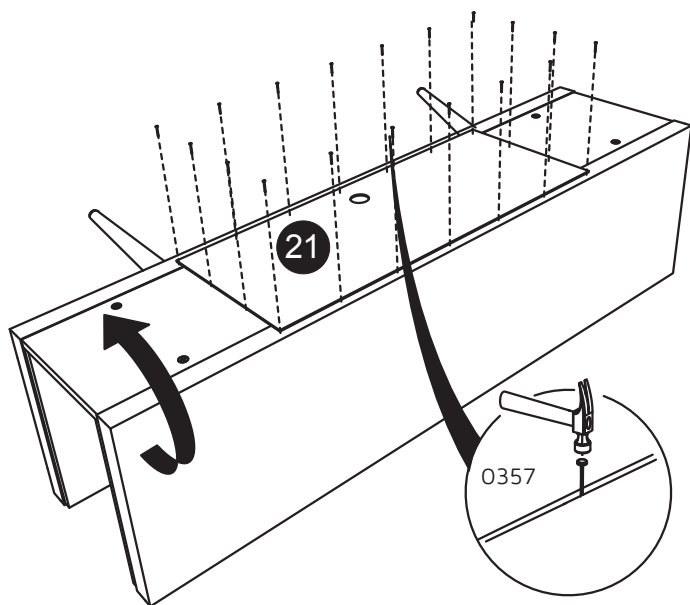

PASSO 14

Encaixar Fundo **21**, pregar **0357**.

STEP 14

Attach Backplate **21**, nailing **0357**.

PASO 14

Enganchar el fondo **21**, clavar **0357**.

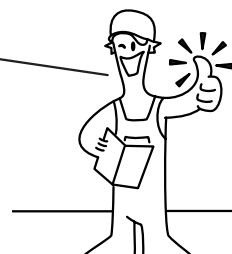
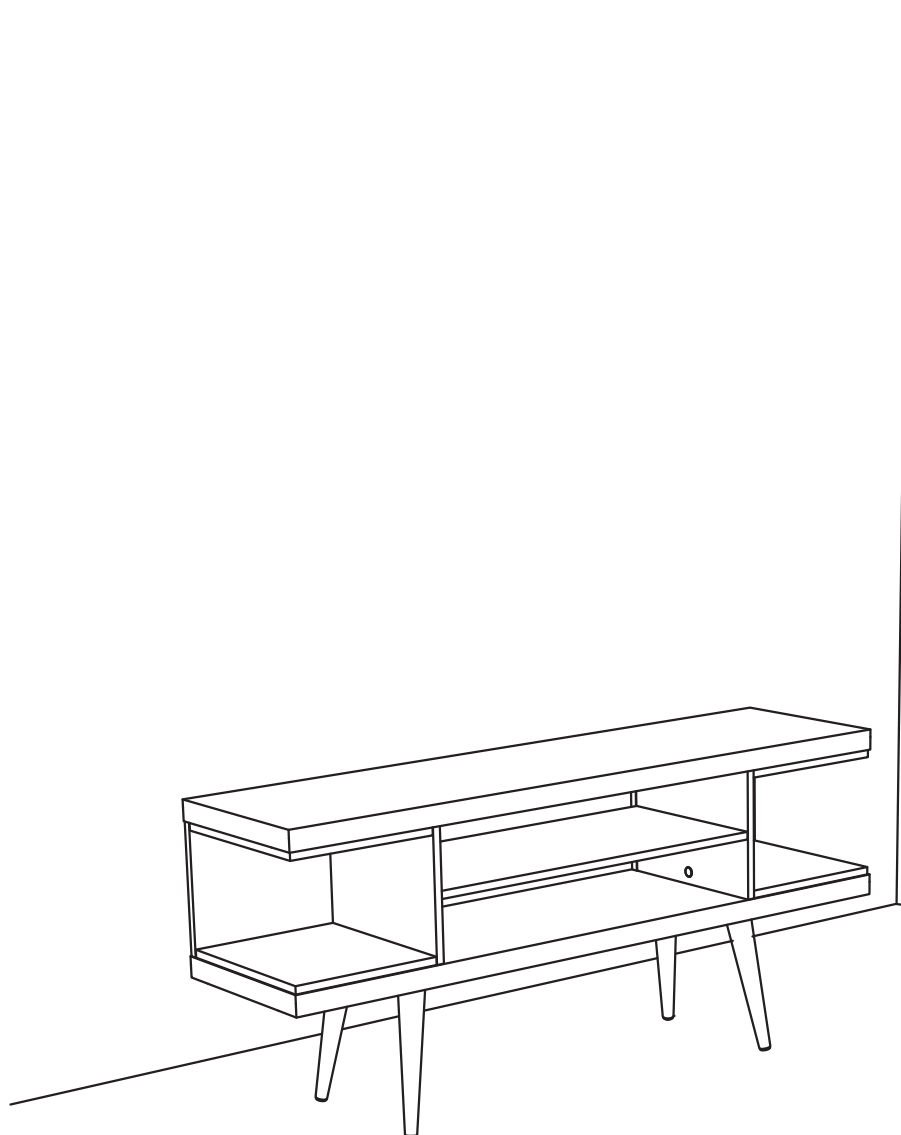

9282