

PRODUCT SPECIFICATIONS

OVERALL ASSEMBLED DIMENSIONS

HEIGHT: 38.7 CM (15-1/4"), WIDTH: 27.2 CM (10-11/16").

1 LIGHT: UL LISTED, 60 WATT, MEDIUM BASE E-27 ALUMINUM SOCKET. ON/OFF PULL CHAIN SWITCH.

GLASS SHADE: CREAM SCAVO GLASS SHADE, 22.9 CM (9") LENGTH x 12.7 CM (5") WIDTH x 7.9 CM (3-1/8") HEIGHT. SHAPED AS SHOWN.

COLUMN: PAINTED STEEL, 4.2 CM (1-5/8") DIA. x 3 CM (1-3/16") HEIGHT. SHAPED AS SHOWN.

POLE: PAINTED STEEL, 2.5 CM (1") REEDED TUBING, 14 CM (5-1/2") LENGTH. SHAPED AS SHOWN.

BASE: PAINTED STEEL, 18 CM (7-1/8") DIA. x 7 CM (2-3/4") HEIGHT. FELT PAD INSTALLED ON BOTTOM OF BASE.

CORD: UL LISTED, MIN 183 CM (6 FT.) LENGTH, 18 AWG., 2 CONDUCTORS, 105°C, TYPE SPT-2, SILVER/CLEAR COLOR, COPPER MATERIAL, PLATED SILVER. WIRES MUST BE LEAD FREE.

LABELS: UL AND CSA OR CUL, MANUFACTURING DATE, MODEL # AND COUNTRY OF ORIGIN LABEL PROVIDED. RELAMPING LABEL FOR 60 WATT MAX. TYPE "A" BULB PROVIDED ON SOCKET.

PACKAGING AND SHIPPING DETAILS

THE LAMP IS ASSEMBLED FOR SHIPPING. THE LAMP IS CAREFULLY WRAPPED IN A PLASTIC BAG AND PLACED SECURELY IN THE INNER PACKING SO IT CAN NOT MOVE AROUND DURING SHIPPING. A SMALL BAG OF SILICA IS INCLUDED IN THE PACKAGE.

THE CARTON IS MADE OF DOUBLE WALL, CORRUGATED CARDBOARD "A MA A". BROWN IN COLOR. THE INNER PACKING IS DIE-CUT CARDBOARD OR STYROFOAM TO PROTECT AND SECURE THE LAMP AND MUST PASS THE FEDEX AND ISTA-3A DROP TEST REQUIREMENTS.

EACH CARTON SHALL BE PRINTED WITH A LINE DRAWING AND THE KENROY HOME NAME AND LOGO, MODEL NUMBER AND FINISH, EACH CARTON SHALL BE PROVIDED A UPC LABEL. THE UPC BAR CODE AS FOLLOWS: ORB=053392099947.

OTHER DETAILS

MODEL 21394ORB INSTRUCTIONS ARE TO BE PACKED WITH EACH LAMP. INSTRUCTIONS MUST BE PRINTED CLEARLY ON QUALITY PAPER.

ALL VISIBLE PARTS, EXCEPT SHADE, MUST MATCH LAMP FINISH UNLESS OTHERWISE SPECIFIED.

ALL BAGS MUST BE LABELED WITH OFFICIAL "THIS BAG IS NOT A TOY" STATEMENT.

LAMP MUST REST FLAT ON SURFACE AND NOT ROCK. LAMP MUST PASS AN 8° TILT TEST.

DIMS OF BOX: 33 CM (13") LENGTH x 25.4 CM (10") WIDTH x 48.9 CM (19-1/4") HEIGHT. (CUFT.: 1.45')

NET WEIGHT: 5.1 LBS. GROSS WEIGHT: 6.4 LBS.

THE UL NUMBER IS E313718.

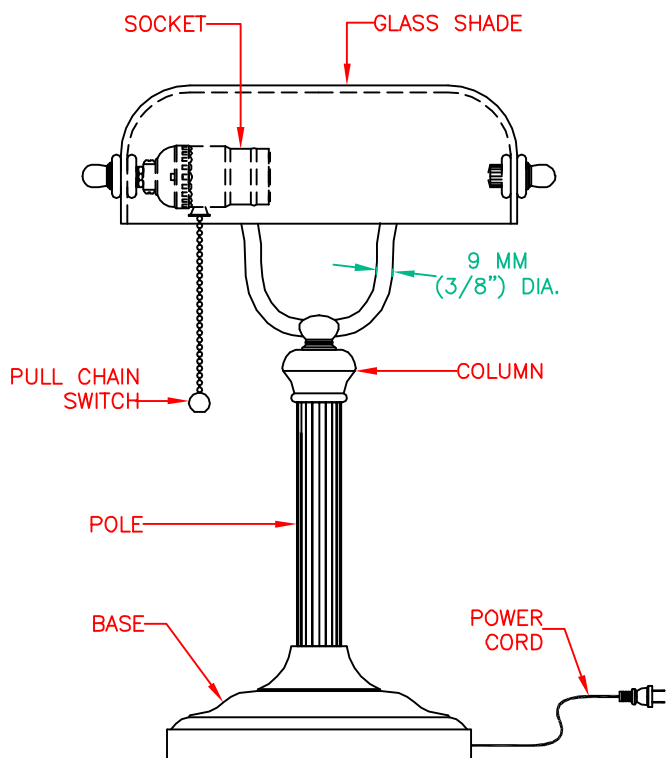

**KENROY
HOME**

3723 Regent Boulevard
JACKSONVILLE, FL. 32224
PHONE: 904-642-4340
FAX: 904-642-4150

THIS DOCUMENT AND THE INFORMATION THAT IT DISCLOSES IS THE EXCLUSIVE PROPERTY OF KENROY HOME. ANY REPRODUCTION OR USE OF THIS DRAWING IN PART OR IN WHOLE, WITHOUT THE EXPRESS CONSENT OF THE PROPRIETOR IS PROHIBITED. © 2008 KENROY HOME.

DATE: 10/20/2008

SCALE: NONE

DRAWN BY: JAMES

REFERENCE: AMHERST BANKER LAMP

APPROVAL:

REVISION DATE:

7/10/2013 add package drawing

REVISION DATE:

3/12/2014 change package drawing

REVISION DATE:

7/1/2014 change UL

REVISION DATE:

8/17/2015 add notes

MODEL #:

21394

FINISHES:

ORB

PAGE:

1

OF: 1