

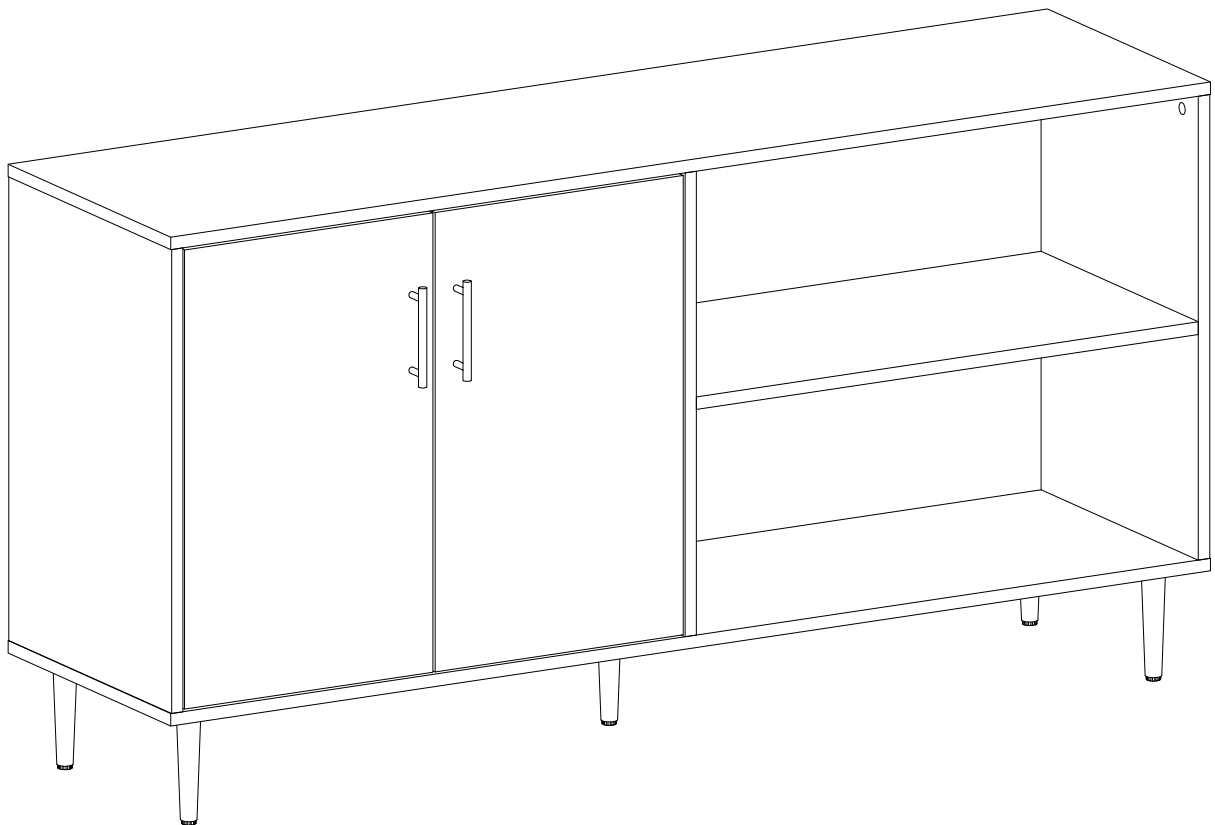

Walker[®]
Edison

Item # : W58BMHPAS
Assembly Instructions



Please visit our website for the most current instructions, assembly tips, report damage, or request parts. www.walkeredison.com

Revised 04/23/2018

General Assembly Guidelines

- I. Ensure that all parts and hardware are available before beginning assembly.
- II. Follow each step carefully to ensure the proper assembly of this product.
- III. Two people are recommended for ease in the assembly of this product.
- IV. The three main types of hardware used to assemble this product are : wood dowels , screws and bolts.
- V. The provided glue is to secure wood dowels in place . When first inserting dowels , locate the appropriate hole for the dowel , place a small amount of glue in the hole and insert the dowel . Wipe away excess glue immediately.

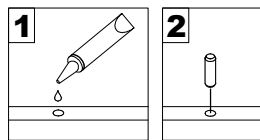

In future assembly steps when dowels are necessary to attach assembly parts together , place a small amount of glue on the end of the dowel before attaching parts together . Wipe away excess glue immediately.

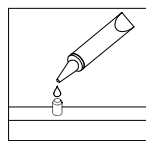

- VI. A Phillips head screwdriver is required for the assembly of this product .

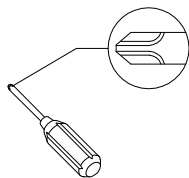



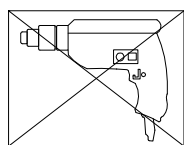



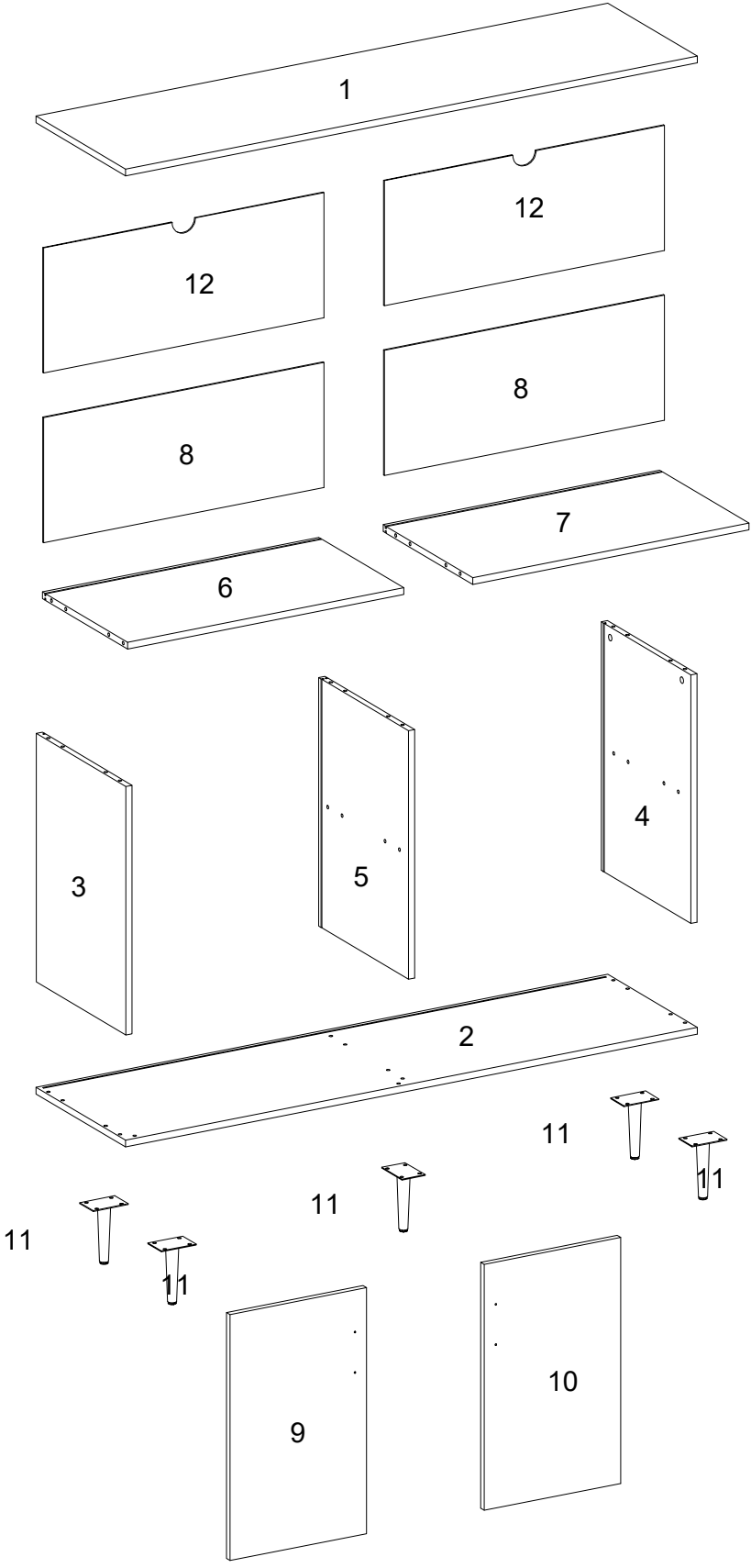







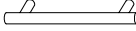

- VII. Power tools should not be used to assemble this product .

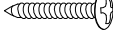

Parts List

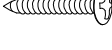

Hardware List

A		Ø8x30mm	Wooden dowel	20 pcs
B		Ø6x35mm	Cam bolt	14 pcs
C		Ø15x11mm	Cam lock	14 pcs
D		Ø6x50mm	Bolt	6 pcs
E			Handle	2 pcs
F		Ø4x22mm	Handle Bolt	4 pcs
G			Bolt	2 pcs
H			Door stopper	1 pcs
J			Door Hinge	2 pcs
K			Door Hinge	2 pcs
L			Plastic pivot	4 pcs
M		Ø3x12mm	Screw	8 pcs
N		Ø6x12mm	Bolt	20 pcs
P		Ø3x17mm	Screw	16 pcs
Q			Glue tube	1 pcs
R		Ø30mm	Sticker	14 pcs
S		M 4	Hex Key	1 pcs
T			Plastic wedge	16 pcs
U		Ø3x15mm	Screw	2 pcs

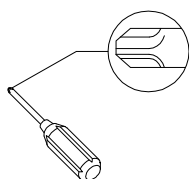

Philips head screwdriver required for assembly
(not included)

*The hardware quantities listed above are required for proper assembly.
Some extra hardware may also have been included.*

Step 1

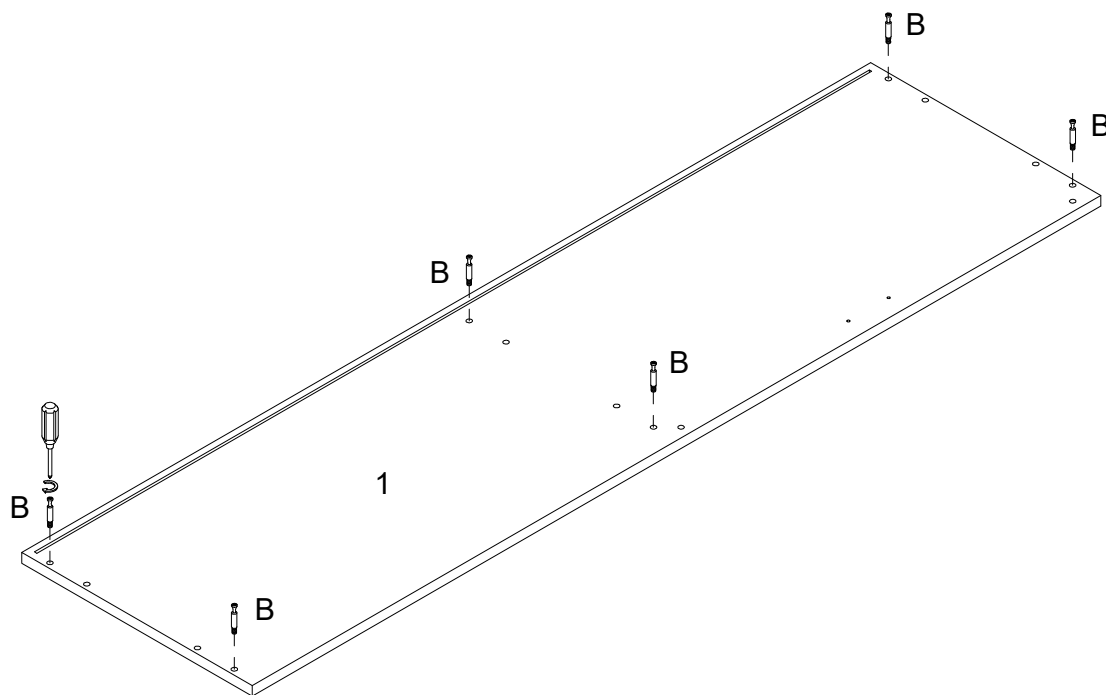

Attach cam bolt (B) to part (1) with screwdriver.

Step 2

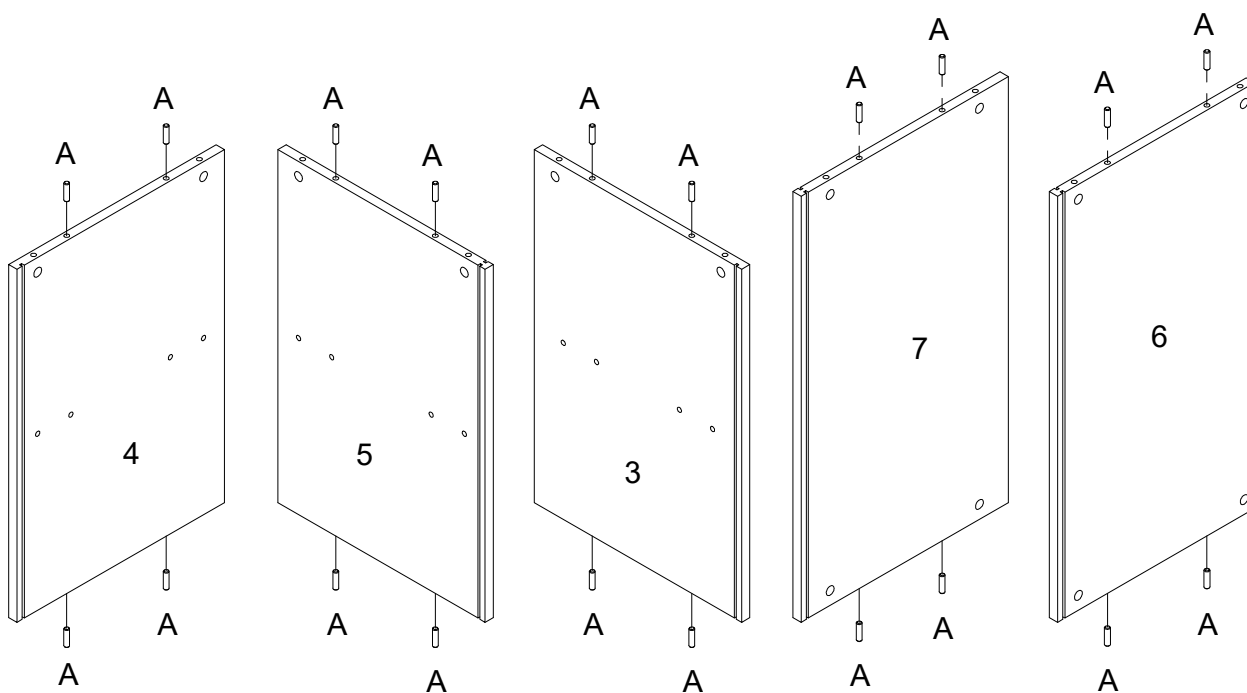

Insert wooden dowel (A) into part (3,4,5,6,7).

Step 3

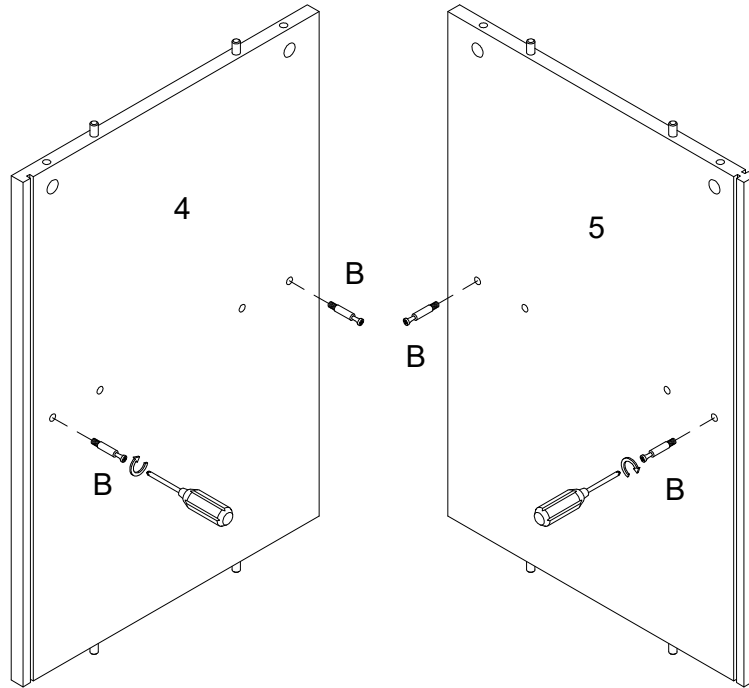

Attach cam bolt (B) to part (4,5) with screwdriver.

Step 4

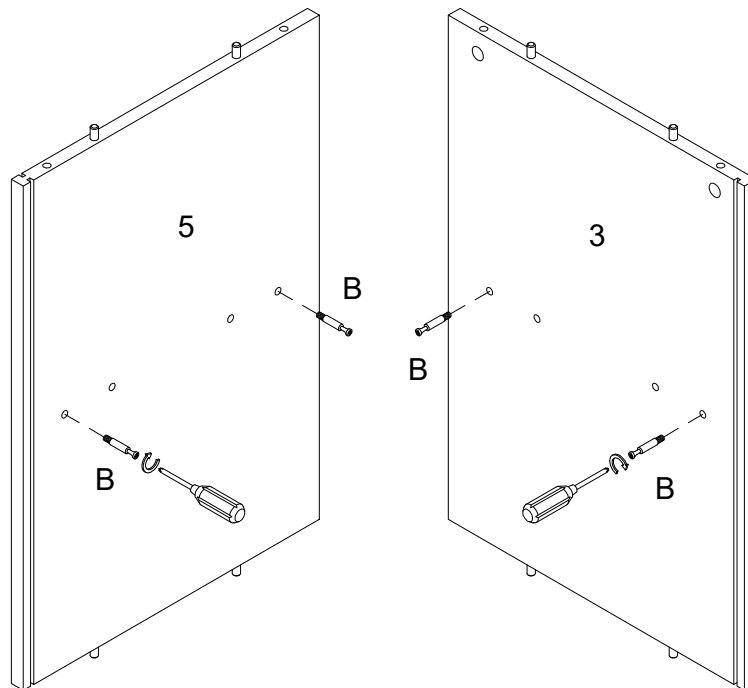

Attach cam bolt (B) to part (3,5) with screwdriver.

Step 5

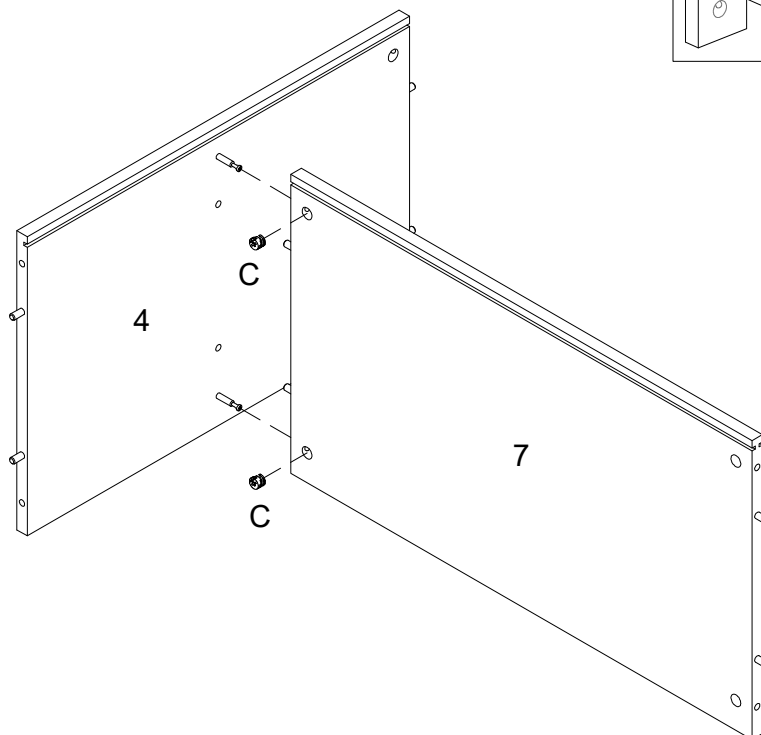
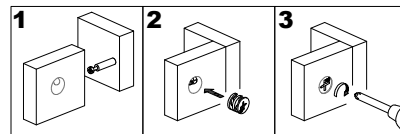

Attach part (4) to part (7), then insert and secure cam lock (C) to part (7) to lock it.

Step 6

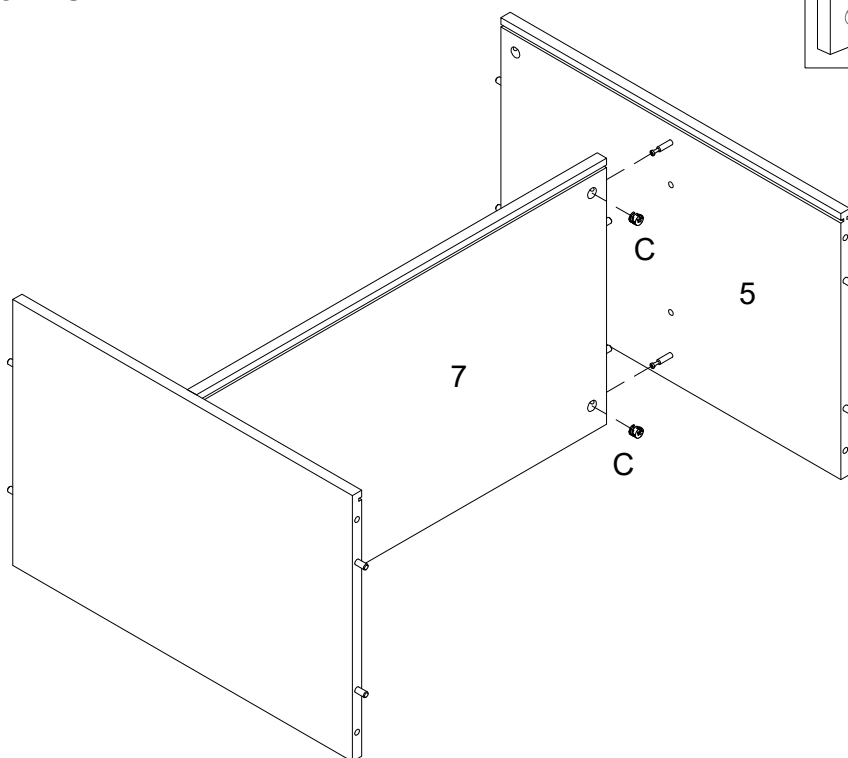
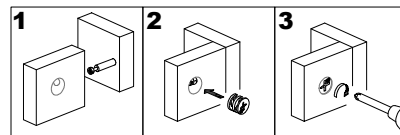

Attach part (5) to part (7), then insert and secure cam lock (C) to part (7) to lock it.

Step 7

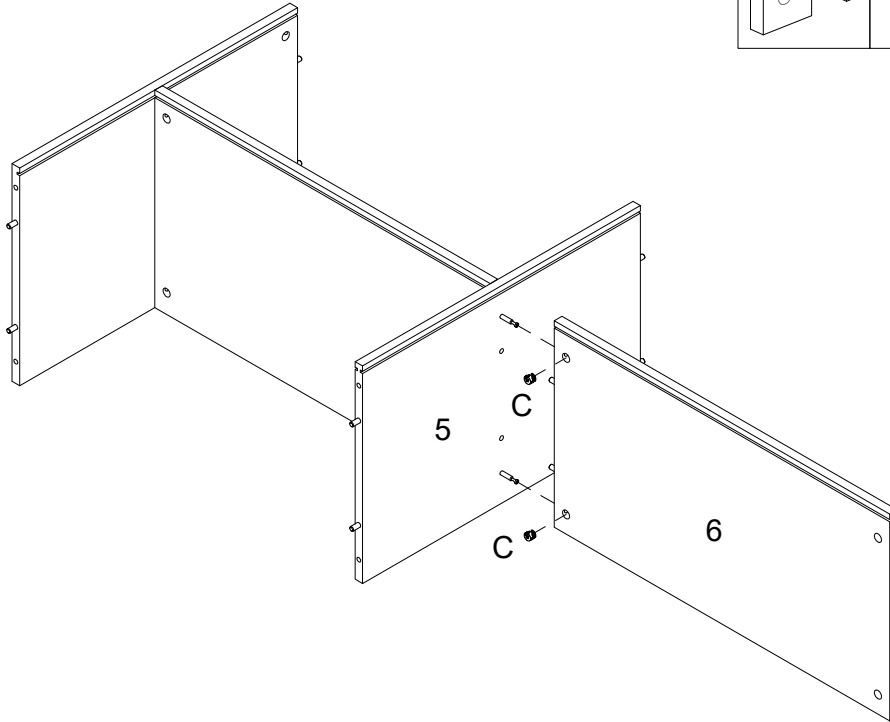
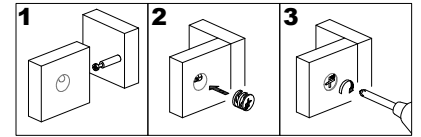

Attach part (5) to part (6), then insert and secure cam lock (C) to part (6) to lock it.

Step 8

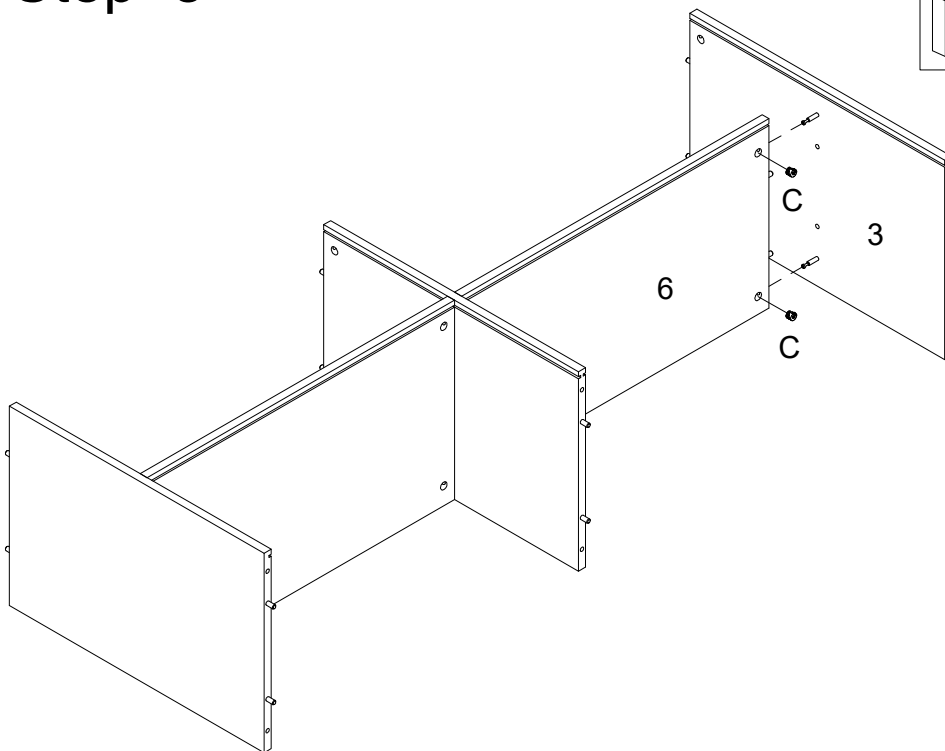
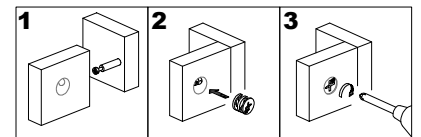

Attach part (3) to part (6), then insert and secure cam lock (C) to part (6) to lock it.

Step 9

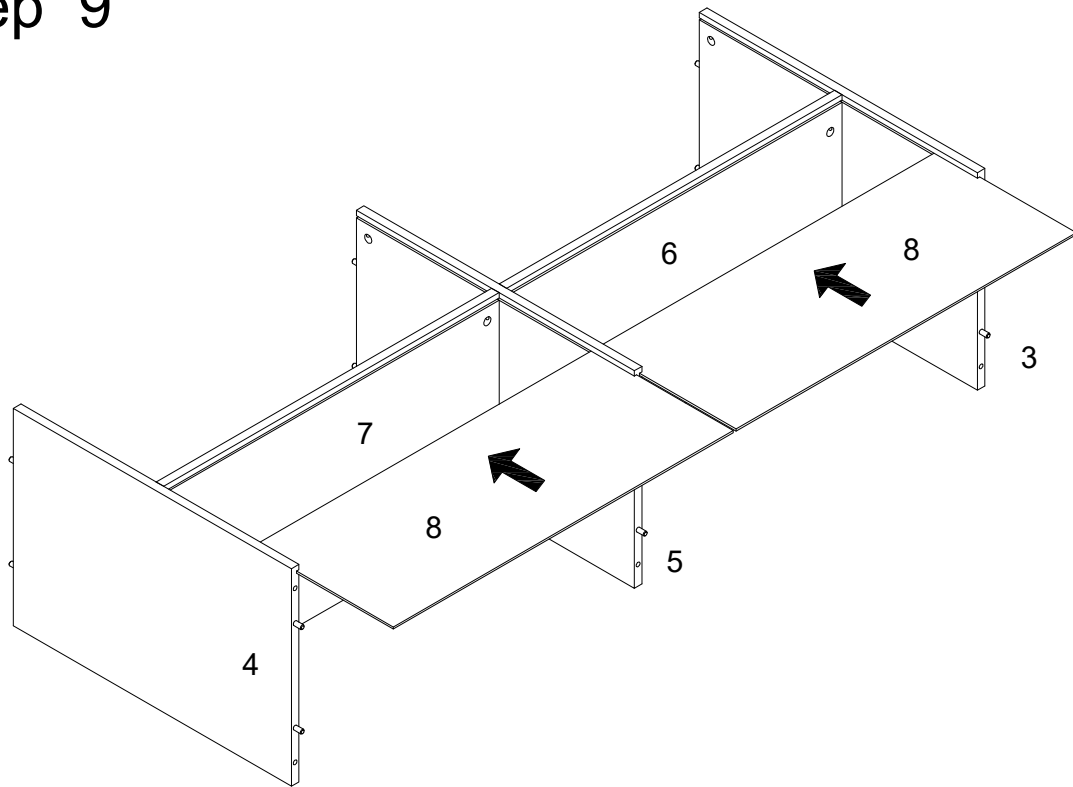

Slide back panel (8) into grooves as per diagram.

Step 10

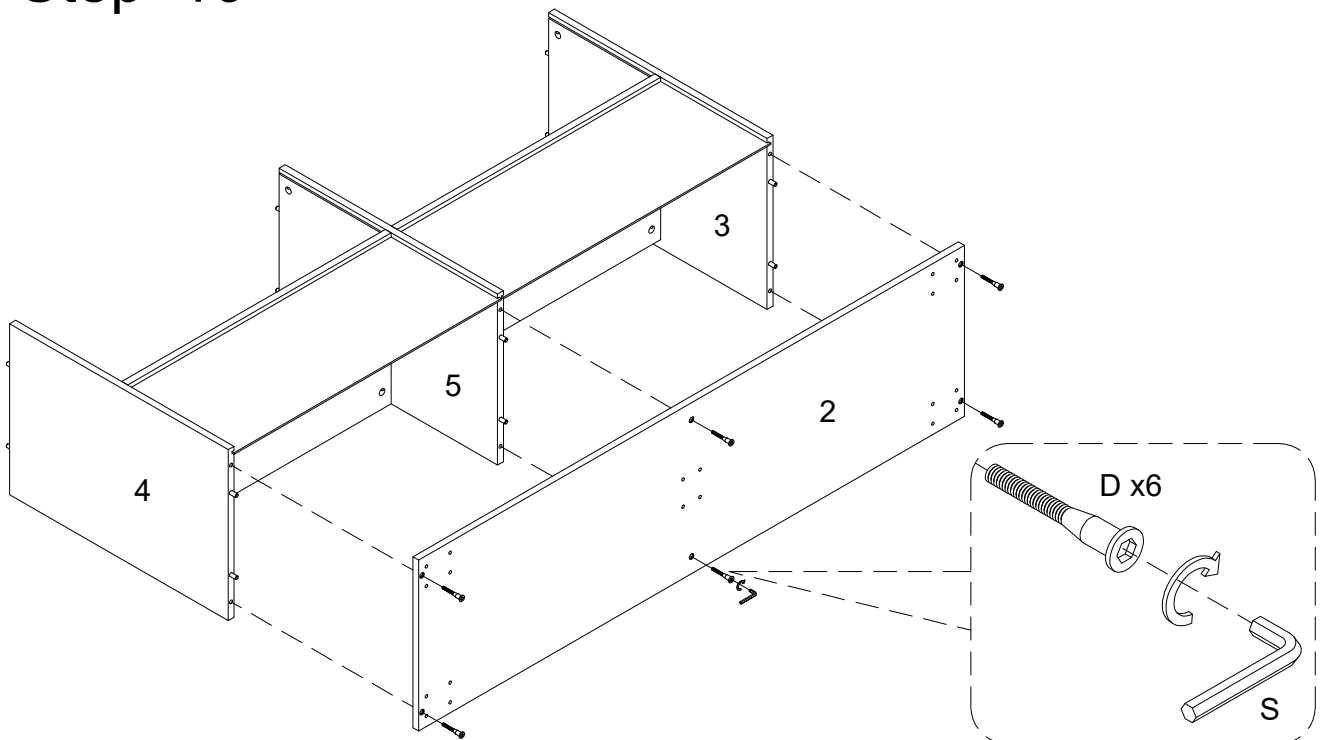

Attach part (2) to part (3,4,5) using bolt (D) with hex key (S).

Step 11

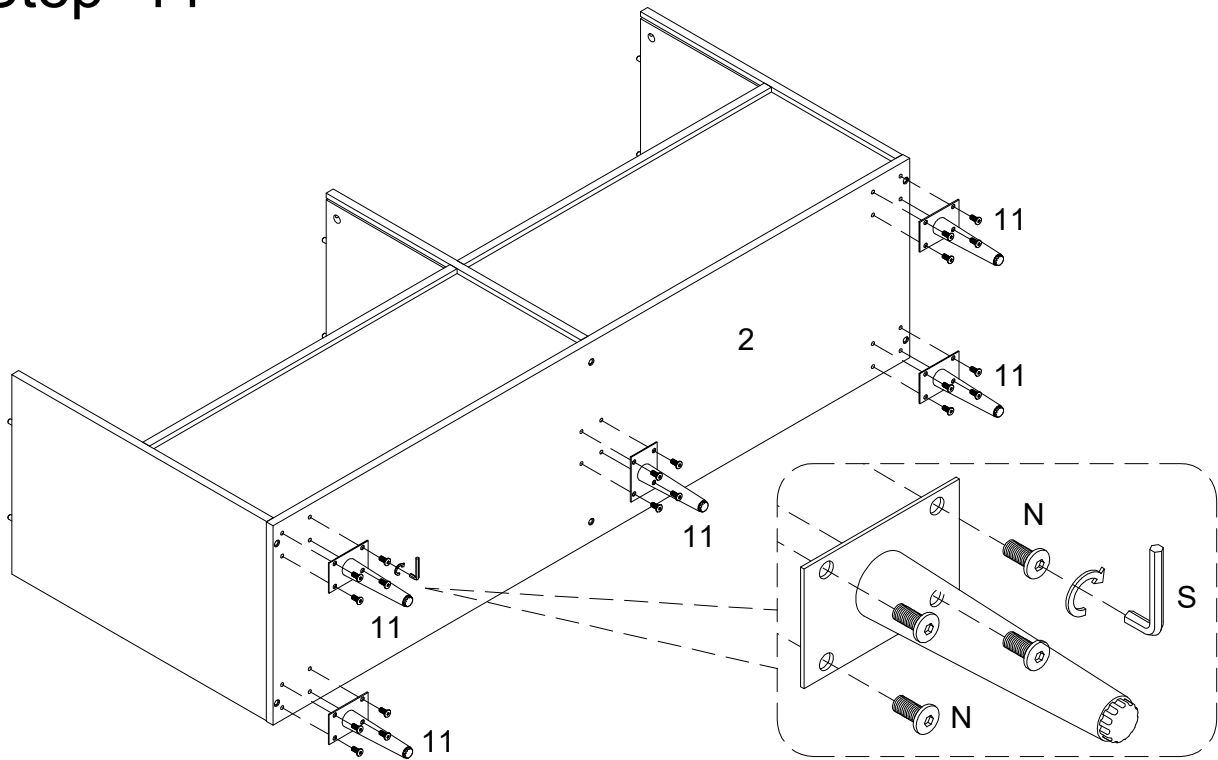

Attach part (11) to part (2) using bolt (N) with hex key (S).

Step 12

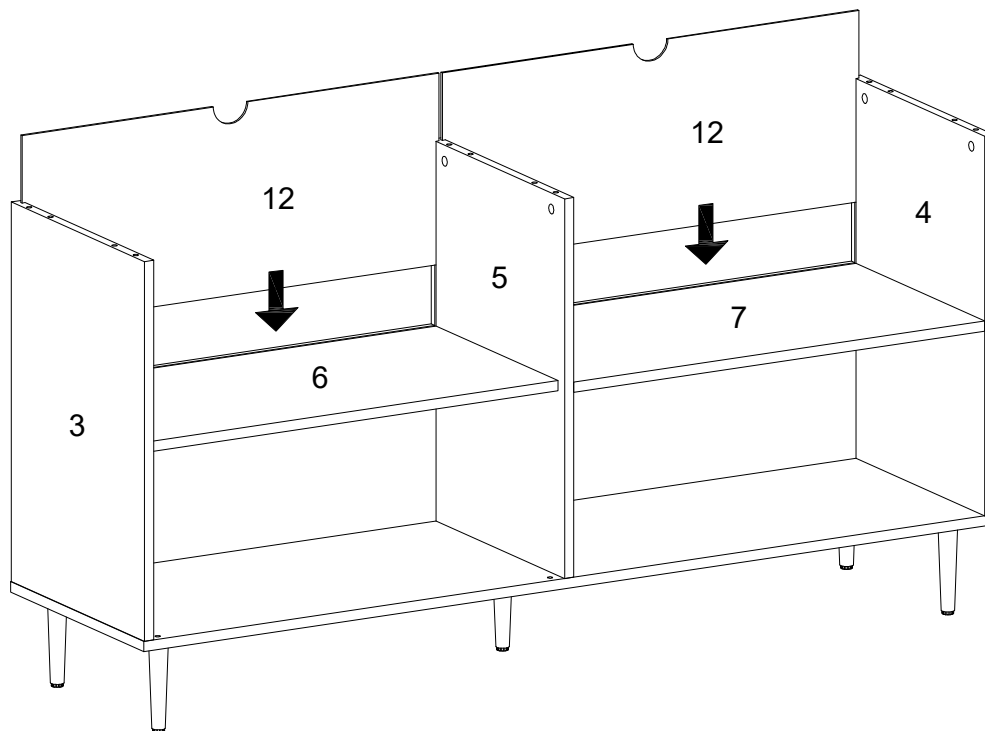

Slide back panel (12) into grooves as per diagram.

Step 13

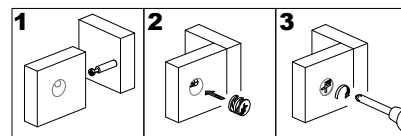
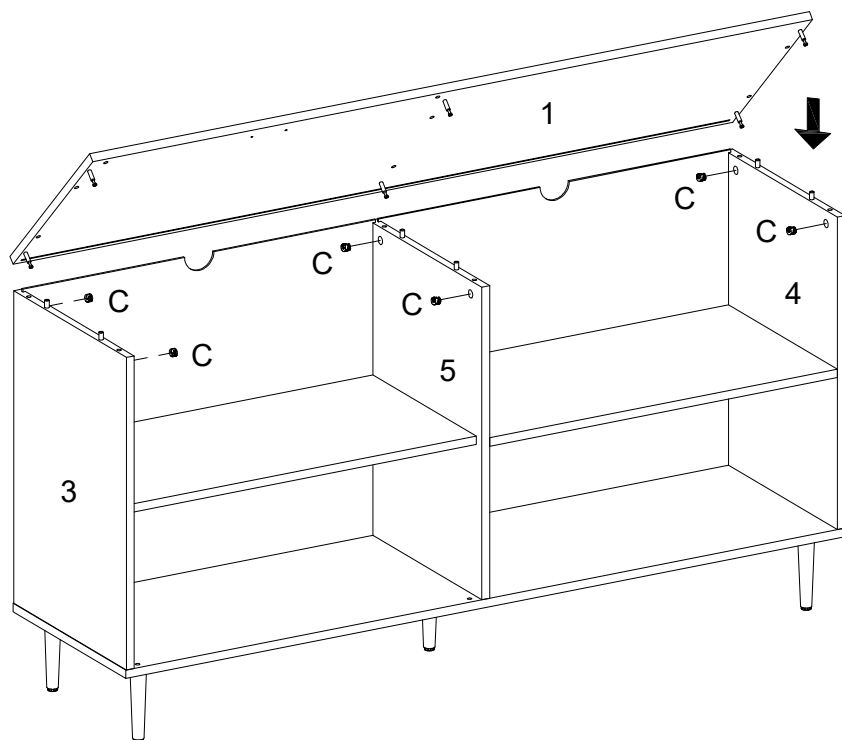

Attach part (1) to part (3,4,5), then insert and secure cam lock (C) to part (3,4,5) to lock it.

Step 14

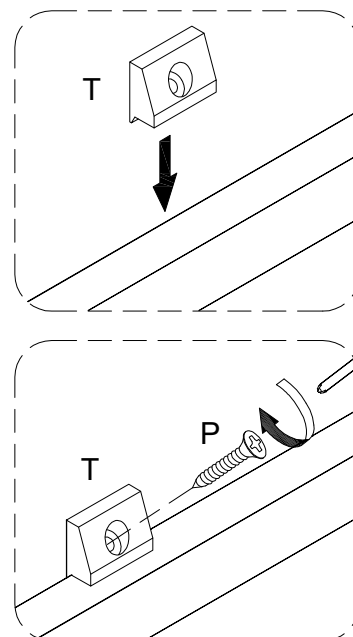
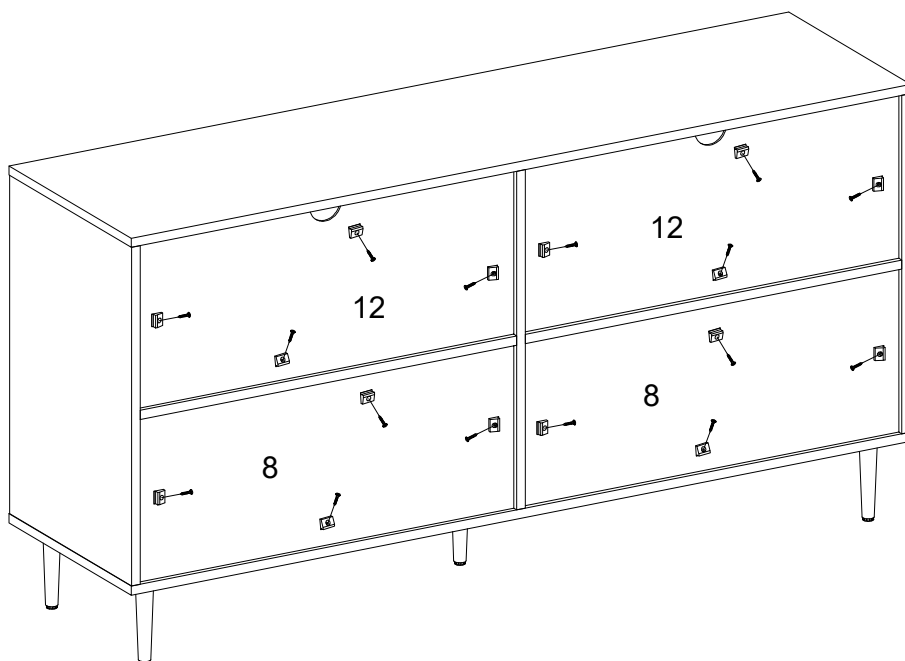

Attach plastic wedge (T) to part (8,12) using screw (P) with screwdriver.

Step 15

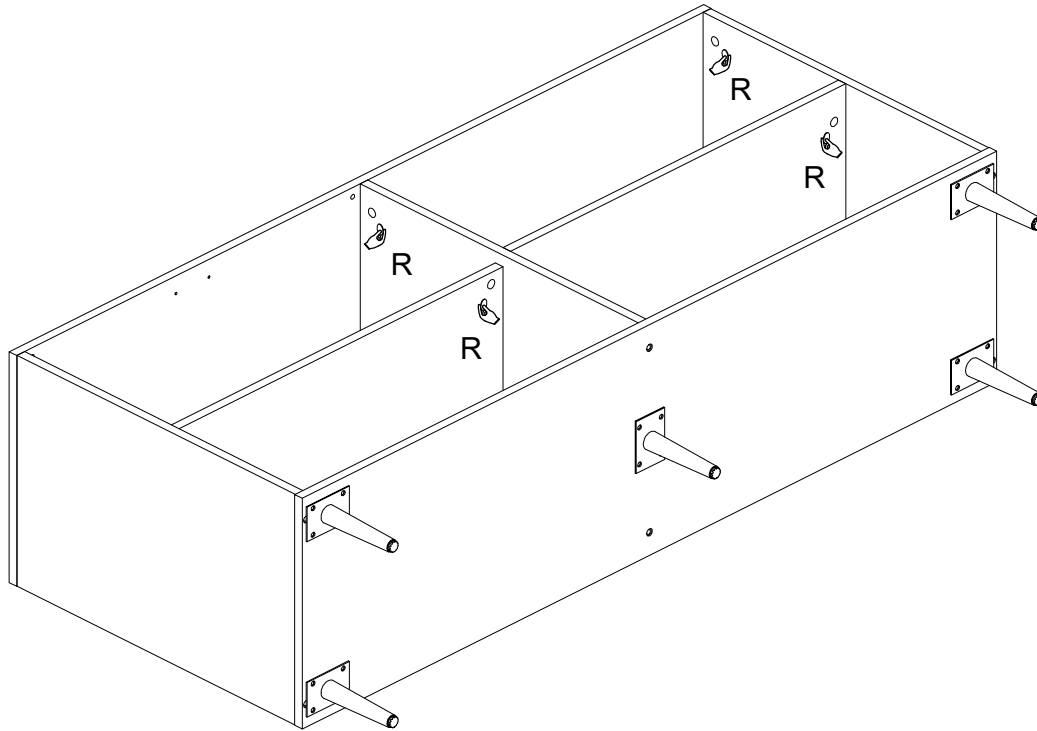

Place sticker (R) over holes as per diagram.

Step 16

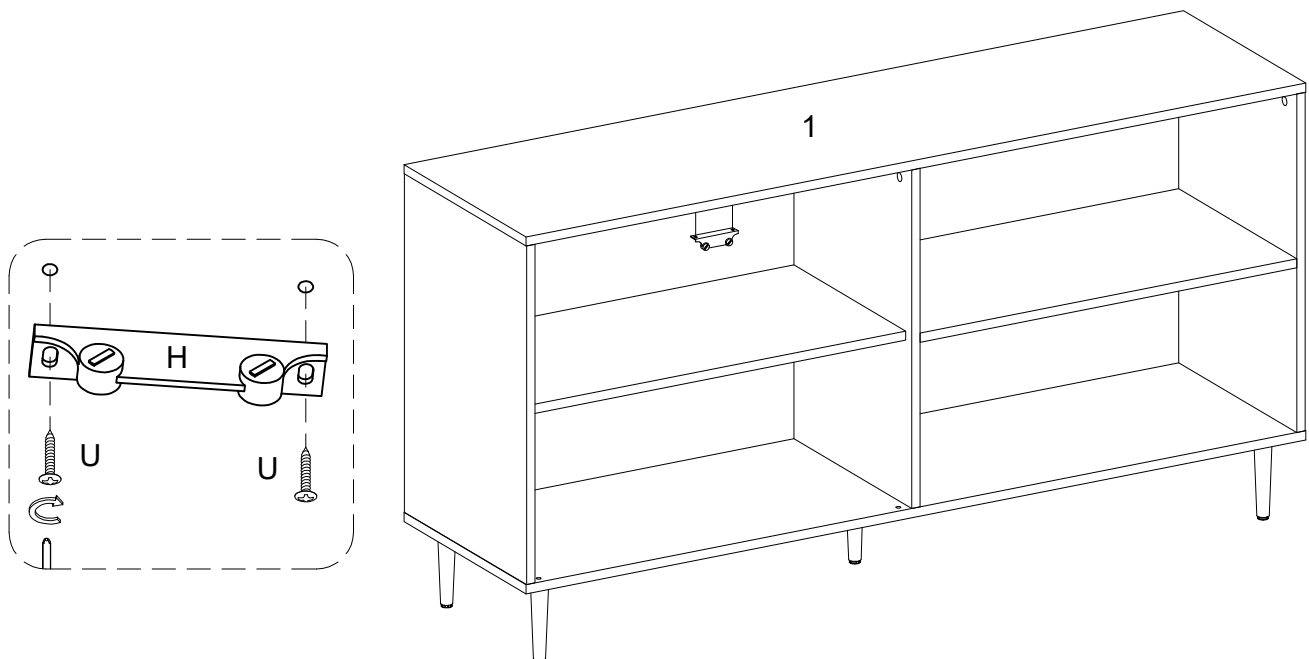

Attach door stopper (H) to part (1) using screw (U) with screwdriver.

Step 17

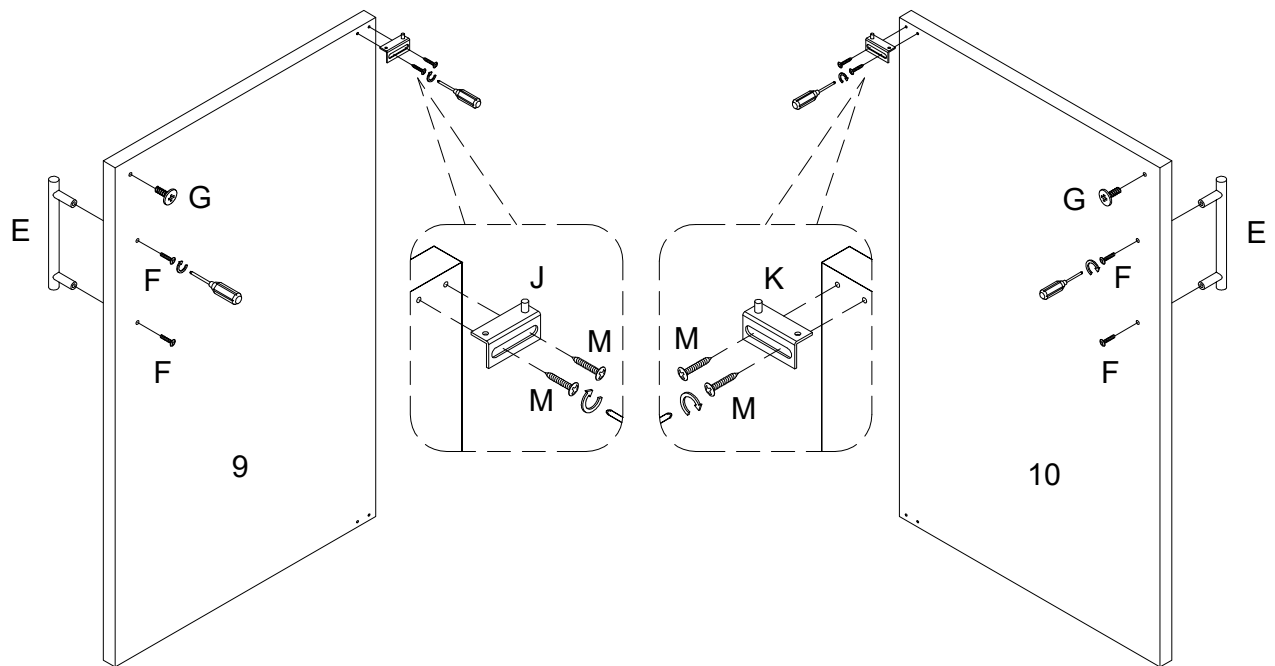

Attach handle (E) to part (9,10) using handle bolt (F) with screwdriver. Attach door hinge (J,K) to part (9,10) using screw (M) with screwdriver. Attach bolt (G) to part (9,10) with screwdriver.

Step 18

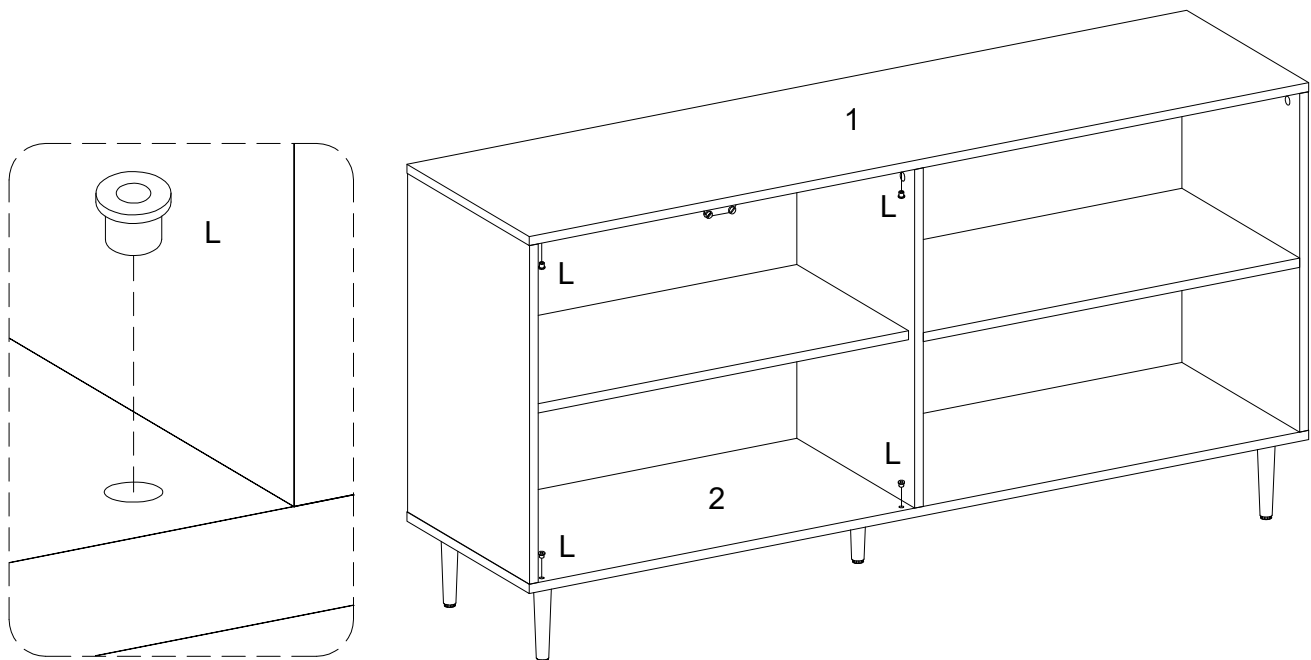

Place plastic pivot (L) over holes as per diagram.

Step 19

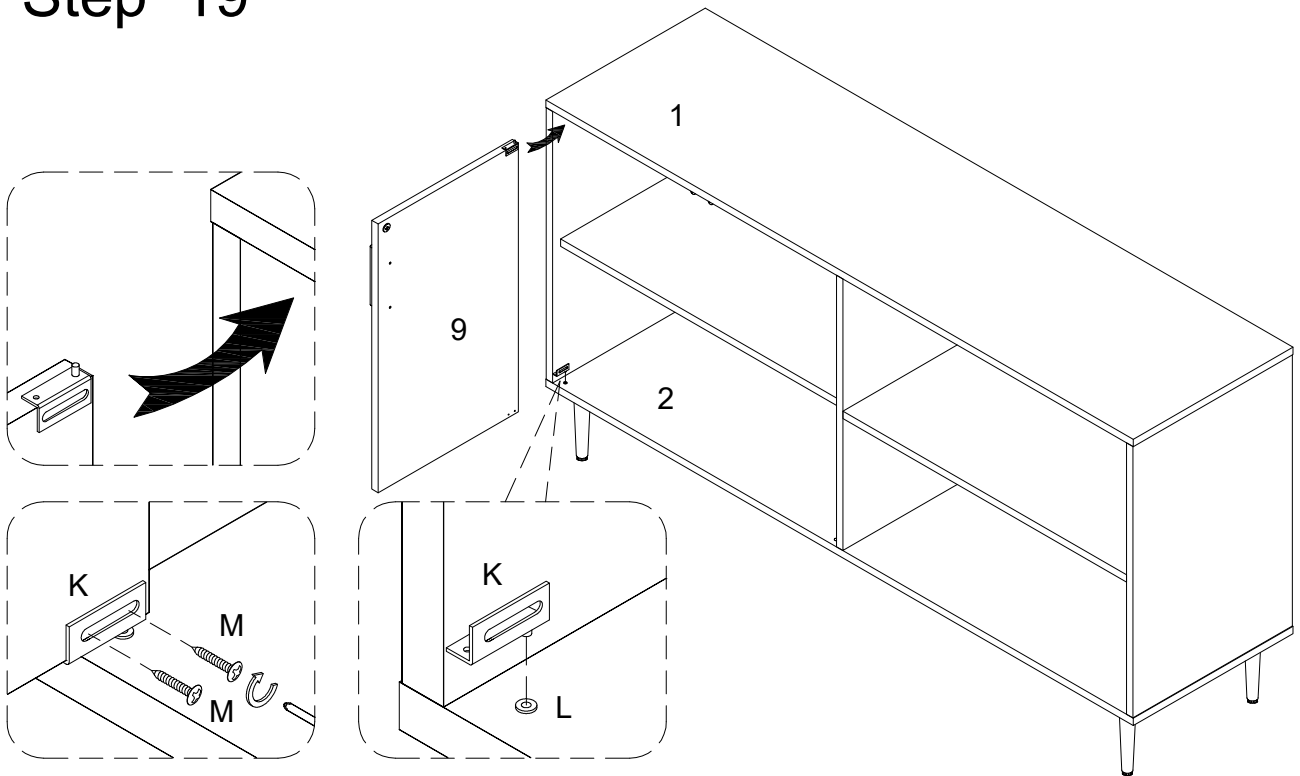

Place door hinge (K) into plastic pivot (L) on part (2). Insert top door hinge into plastic pivot (N) on part (1), then slide the door (9) into the bottom hinge (K). Secure door by tightening door hinge (K) using screws (M) with equal pressure.

Step 20

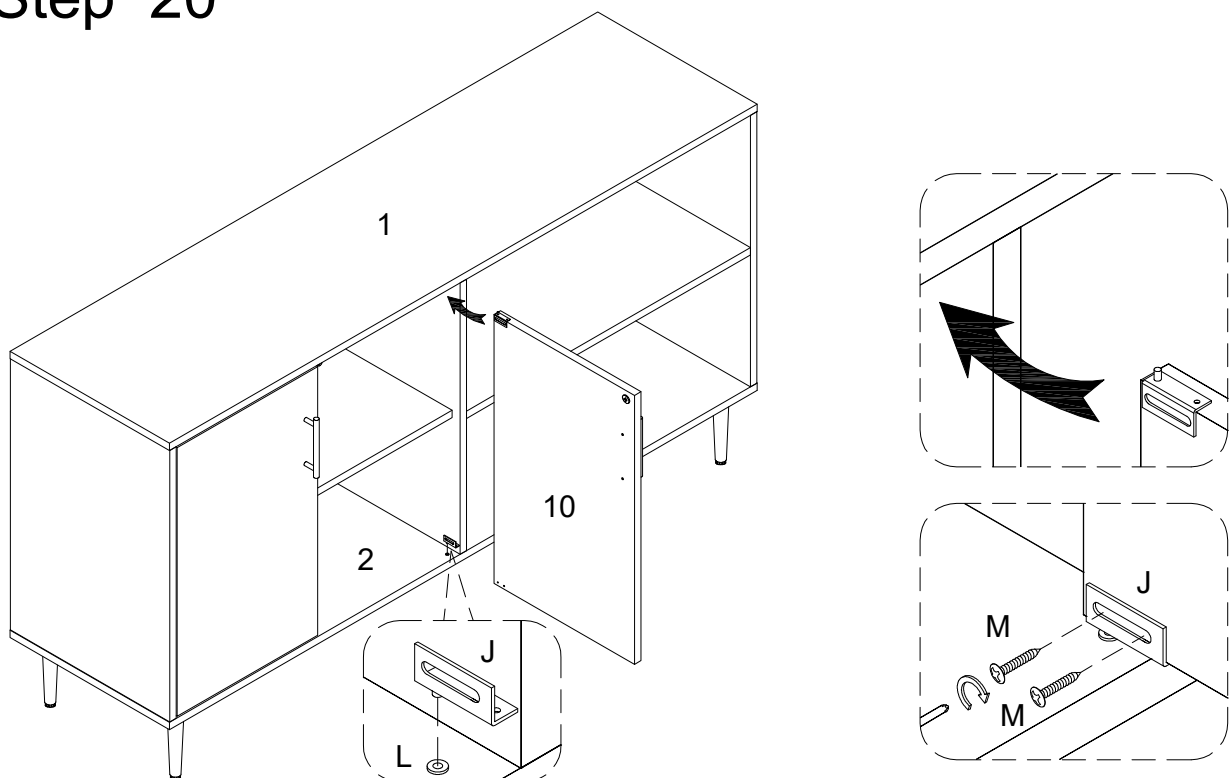

Place door hinge (J) into plastic pivot (L) on part (2). Insert top door hinge into plastic pivot (N) on part (1), then slide the door (10) into the bottom hinge (J). Secure door by tightening door hinge (J) using screws (M) with equal pressure.

Step 21

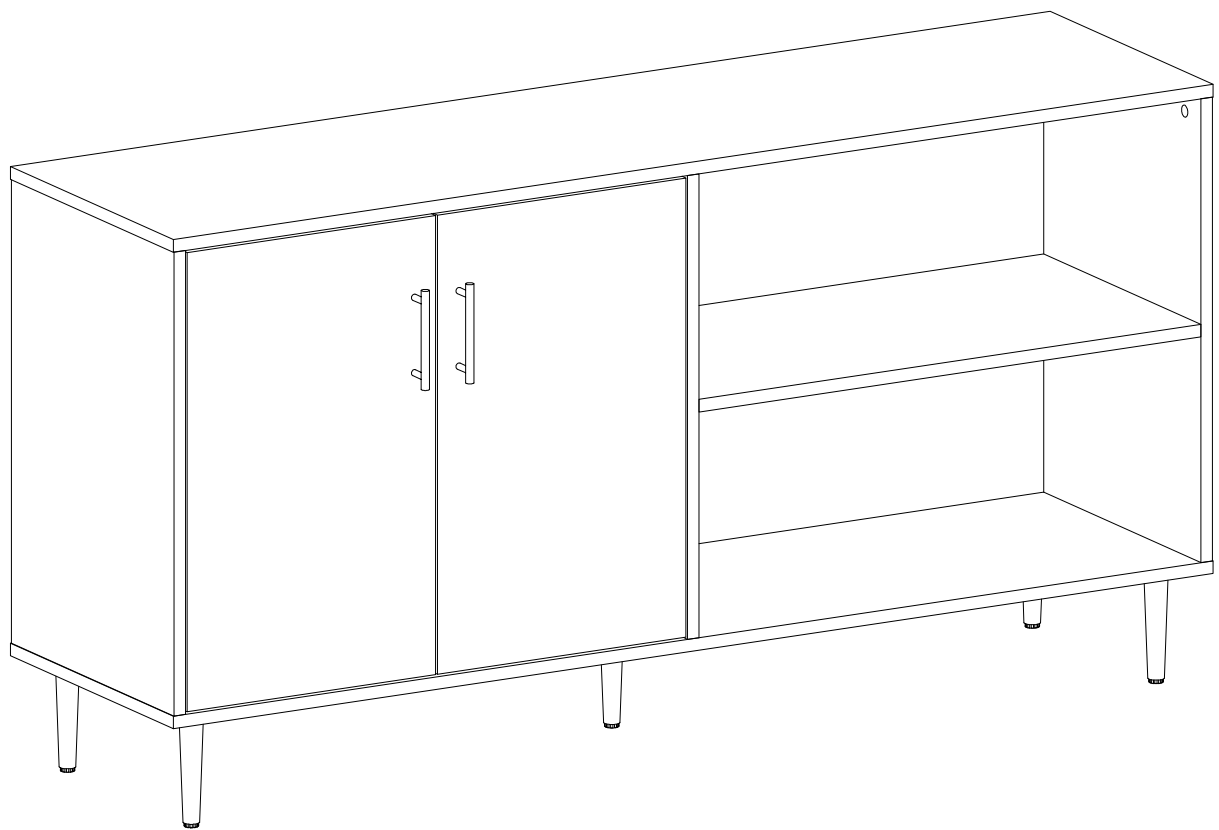

Final Assembly