

Front View

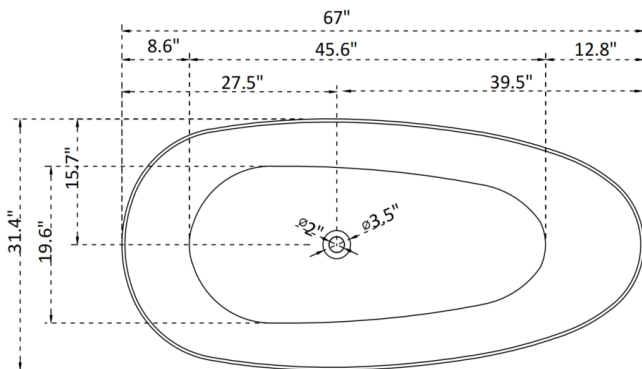

Top View

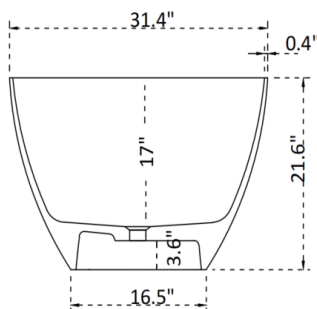

Side View

! **DISCLAIMER:** Following installation, refrain from caulking the tub base initially. Securely fasten all connections and thoroughly inspect for water seepage to validate correct installation. Fill and drain the tub multiple times, checking for leaks before applying caulking.

DESCRIPTION

In the avant-garde design of the Ancerre Designs Anjuna freestanding bath, a harmonious fusion of elegance, strength, and distinctiveness is captured—a seamless marriage of beauty and enduring resilience. Its ergonomically crafted tub invites a profound and relaxing soak, ensuring optimal body support. Meticulously handcrafted from forged carbon fiber material with a one-piece seamless construction, this bath assures unparalleled durability. The graceful lines and straight shroud effortlessly integrate with a variety of bathroom styles, imparting versatility, and refined style to any space.

KEY FEATURES

- Material: Forged Carbon Fiber
- Water Capacity : 97 Gallons.
- Inclusive of a pop-up drainer and flexible hose.
- Faucet not included.
- 3 Years Warranty.
- Unrivald comfort achieved through impeccably designed ergonomic structure.
- Streamlined and expeditious installation process.

Product Size : 67"W x 31.4"D x 21.6"H

Package Size : 71"W x 35"D x 28"H

Net Weight: 114 lbs

Gross Weight: 235 lbs

Color Finish: Forged Carbon Fiber(CF)