

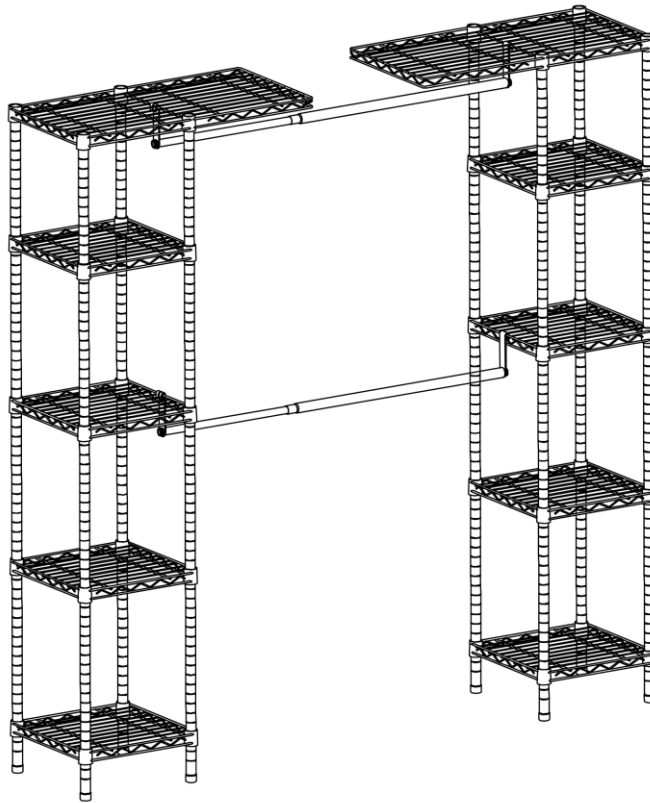

Everything in its place.®

# OWNER'S MANUAL



**TRINITY EXPANDABLE CLOSET ORGANIZER**

**Model # TBFZ-2701 / TBFPBR-2701**

# PARTS LIST

Your TRINITY Expandable Closet Organizer should include the following parts. Please inspect box contents to ensure you have received all components.

If you are missing any parts, need assistance with assembly or have questions, please contact TRINITY Customer Service: 800.985.5506 or [customerservice@trinityii.com](mailto:customerservice@trinityii.com). Parts can also be requested online at [www.trinityii.com](http://www.trinityii.com) (Help & More, Contact Us).

A

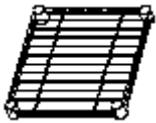

**SMALL SHELF (8)**

B



**TOP SHELF (2)**

C



**BAMBOO BOARD (8)**

D



**TOP POLE (8)**  
End Cap pre-installed

E



**MIDDLE POLE (8)**

F



**BOTTOM POLE (8)**  
Threaded Insert pre-installed

G



**HANGING ROD (2)**

H



**HANGING BRACKET (4)**

I



**HANGING SCREW (4)**

J



**SLIP SLEEVE (80) + (2) extra**

K



**LEVELER (8)**

L



**CONNECTOR (16)**

M

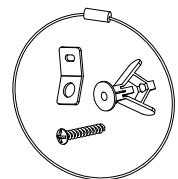

**ANTI-TIPPING KIT (2)**

# ASSEMBLY INSTRUCTIONS

## STEP 1

Screw each LEVELER (K) into the bottom of each BOTTOM POLE (F). Turn clock-wise to screw in place.

Starting from the bottom of the BOTTOM POLE (F), attach two pieces of black plastic SLIP SLEEVES (J) on either side of the pole in the desired groove. Slide the plastic SLIP SLEEVES (J) down until they click into position. Repeat for the other three poles.

Tip: Use the grooves on the pole as a guide to ensure a level shelf height.

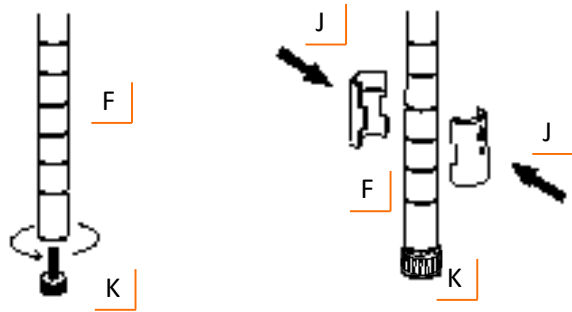
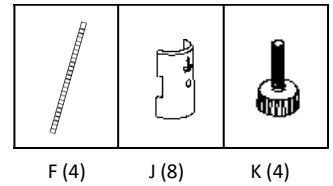

## STEP 2

With the SMALL SHELF (A) on its side, slide each of the BOTTOM POLES (F) through the shelf collars.

Stand the unit upright and push down on the SMALL SHELF (A). Using a rubber mallet to lightly hammer the SMALL SHELF (A) down over the collars is helpful but not necessary.

Note: For stability, the lowest SMALL SHELF (A) should be installed **no higher** than the 3rd indentation from the bottom of the BOTTOM POLES (F).

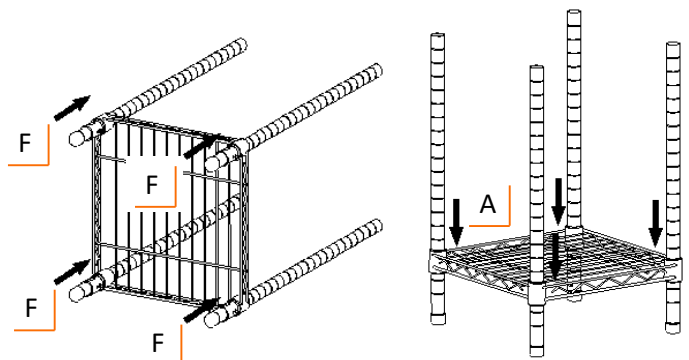
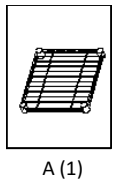

# ASSEMBLY INSTRUCTIONS

## STEP 3

Attaching black plastic SLIP SLEEVES (J) onto the poles in the desired grooves, slide the 2nd SMALL SHELF (A) from the top of the BOTTOM POLES (F) onto the pairs of black plastic SLIP SLEEVES (J).

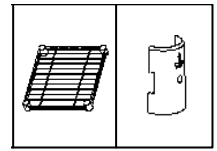
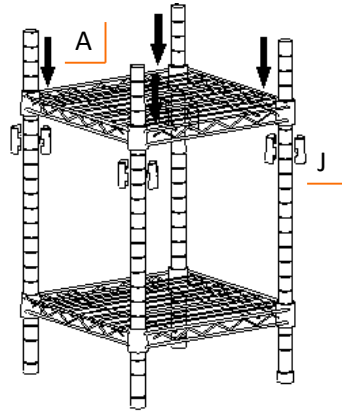

A (1) J (8)

## STEP 4

Screw the CONNECTORS (L) into the top of the BOTTOM POLES (F), connect the four MIDDLE POLES (E) and the four BOTTOM POLES (F) with the CONNECTORS (L).

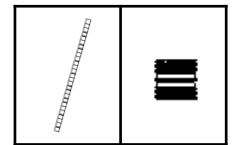
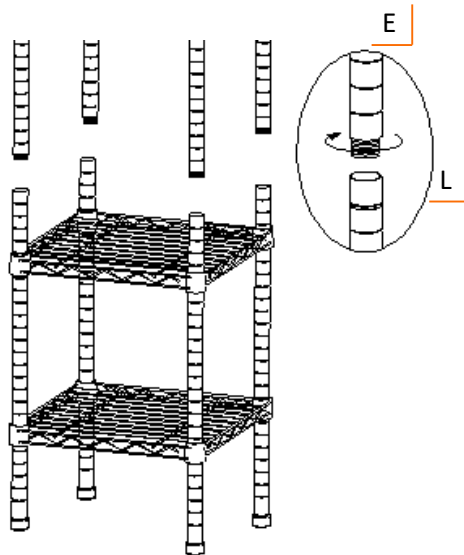

E (4) L (4)

# ASSEMBLY INSTRUCTIONS

## STEP 5

Repeat STEP 3 for assembly of the 3rd SMALL SHELF (A)

Screw the CONNECTORS (L) into the top of the MIDDLE POLES (E), connect the four TOP POLES (D) and the four MIDDLE POLES (E) with the CONNECTORS (L).

Repeat STEP 3 for assembly of the 4th SMALL SHELF (A)

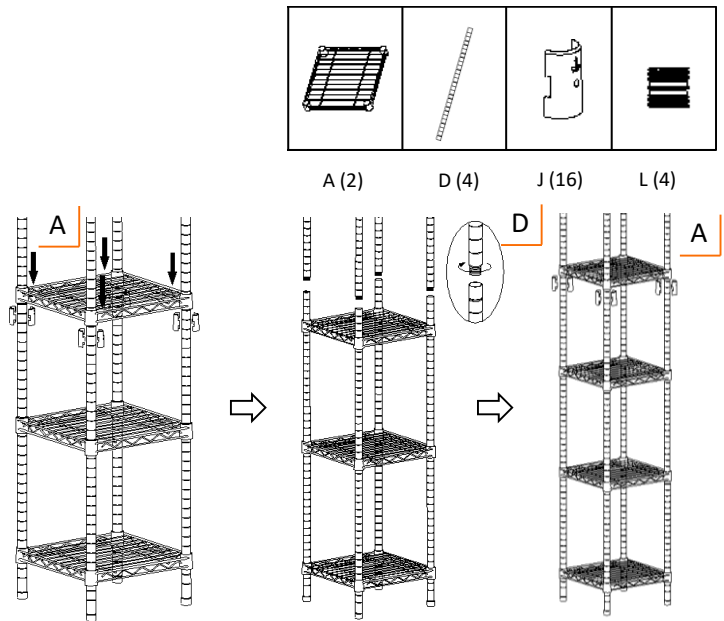

## STEP 6

Repeat STEP 3 for assembly of the TOP SHELF (B)

The first tower is ready. Repeat STEP 1 through STEP 6 to assemble the second tower.

Note: For stability, the TOP SHELF (B) should be installed ***no lower*** than the 3<sup>rd</sup> indentation from the top.

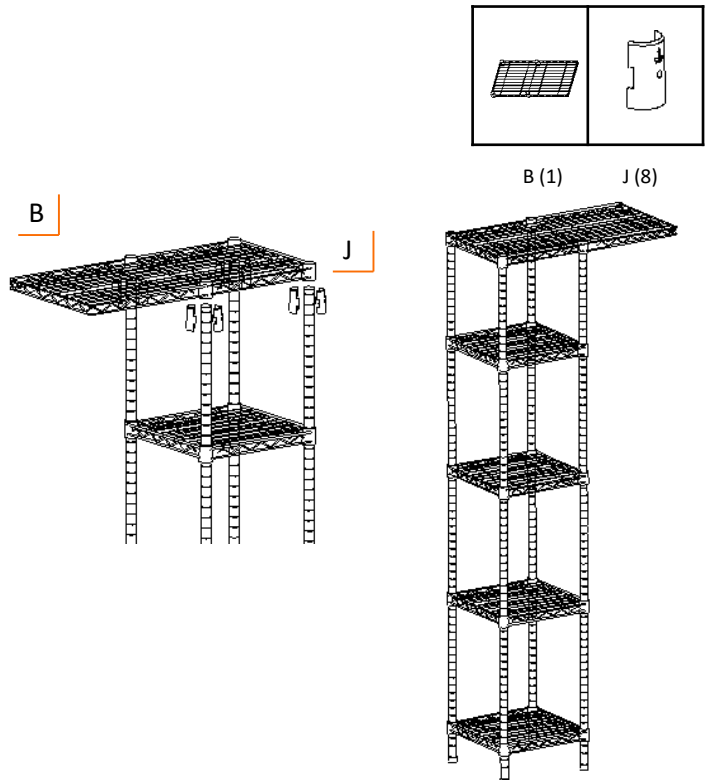

# ASSEMBLY INSTRUCTIONS

## STEP 7

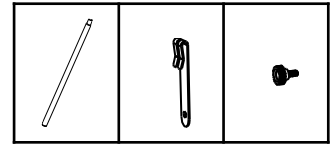

Top: Hang the HANGING BRACKET (H) over the wire strand in the middle of the TOP SHELF (B). Do the same for the other side.

Bottom: Hang the HANGING BRACKET (H) over the lip of SMALL SHELF (A). Do the same for the other side.

Fasten HANGING SCREW (I) through HANGING BRACKET (H) to HANGING ROD (G). Do this for both HANGING RODS (G).

Note: The organizer is able to fit closet widths ranging from 56" to 78". Please place towers in position before expanding the HANGING ROD (G) and attach to HANGING BRACKET (H) with HANGING SCREW (I).

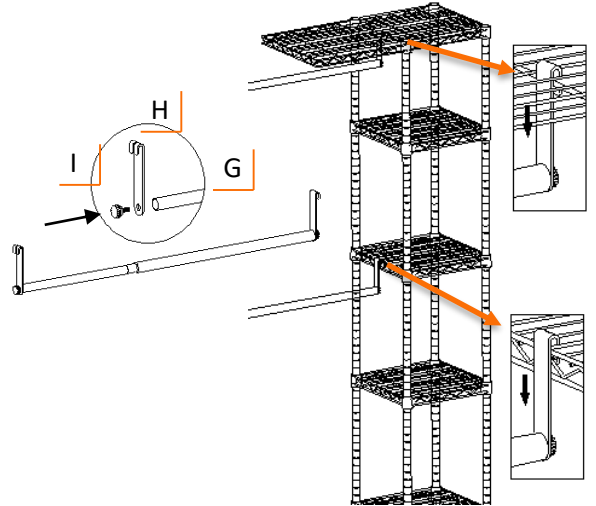

## STEP 8

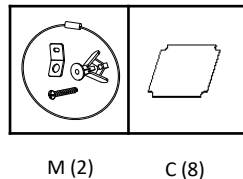

Place CLOSET ORGANIZER by the wall, drill 1 hole on each side of the wall at the same level of TOP SHELF (B) where ANTI-TIPPING KIT (M) is desired to be placed.

Fasten ANTI-TIPPING KIT (M) to the wall and cable loop through TOP SHELF (B) as the image shows, and close up the cable loop, connecting CLOSET ORGANIZER to the wall via ANTI-TIPPING KIT (M).

Place each BAMBOO BOARD (C) onto each SMALL SHELF (A) as shown.

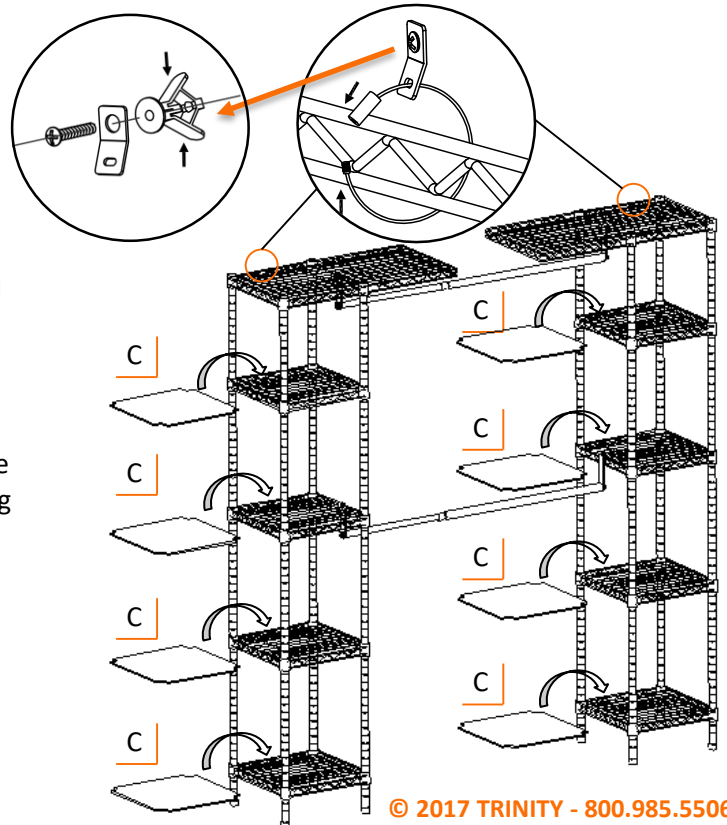

## SERVICE PARTS LIST – TBFBR-2701 Bronze Color

TRINITY Customer Service provides the following replacement parts:

Part Number	Description	Part Number	Description
1) XBK-01-012-2543	Slip Sleeve	8) ONA-20-003-1313	Bamboo Board
2) PBR-04-006-2750	Top Pole	9) PBR-13-008-2600	Hanging Rod
3) ZSV-01-013-2523	Pole Connector	10) XBK-01-024-0627	Hanging Screw
4) PBR-04-007-2800	Middle Pole	11) PBR-02-010-0001	Hanging Bracket
5) PBR-03-007-1414	Small Shelf	12) PBR-03-024-1428	Top Shelf
6) PBR-04-008-2700	Bottom Pole	13) XSV-02-011-0007	Anti-tipping kit
7) XBK-98-003-2538	Feet Leveler		

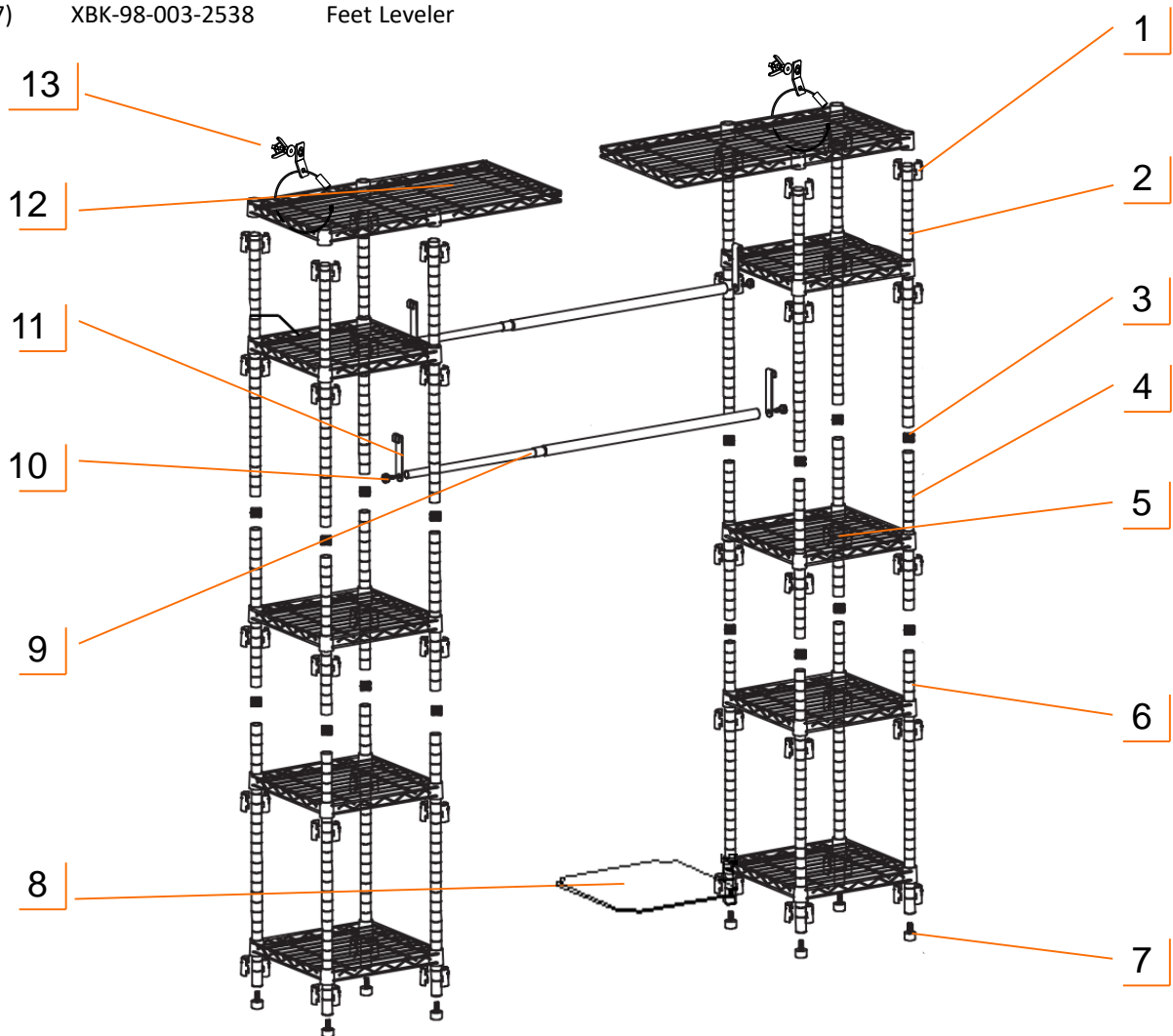

# SERVICE PARTS LIST – TBFZ-2701 Chrome Color

TRINITY Customer Service provides the following replacement parts:

Part Number	Description	Part Number	Description
1) XBK-01-011-2543	Slip Sleeve	8) ONA-20-003-1313	Bamboo Board
2) ZSV-04-006-2750	Top Pole	9) ZSV-13-008-2600	Hanging Rod
3) ZSV-01-013-2523	Pole Connector	10) XBK-01-024-0627	Hanging Screw
4) ZSV-04-007-2800	Middle Pole	11) ZSV-02-010-0001	Hanging Bracket
5) ZSV-03-007-1414	Small Shelf	12) ZSV-03-024-1428	Top Shelf
6) ZSV-04-008-2700	Bottom Pole	13) XSV-02-011-0007	Anti-tipping kit
7) XBK-98-003-2538	Feet Leveler		

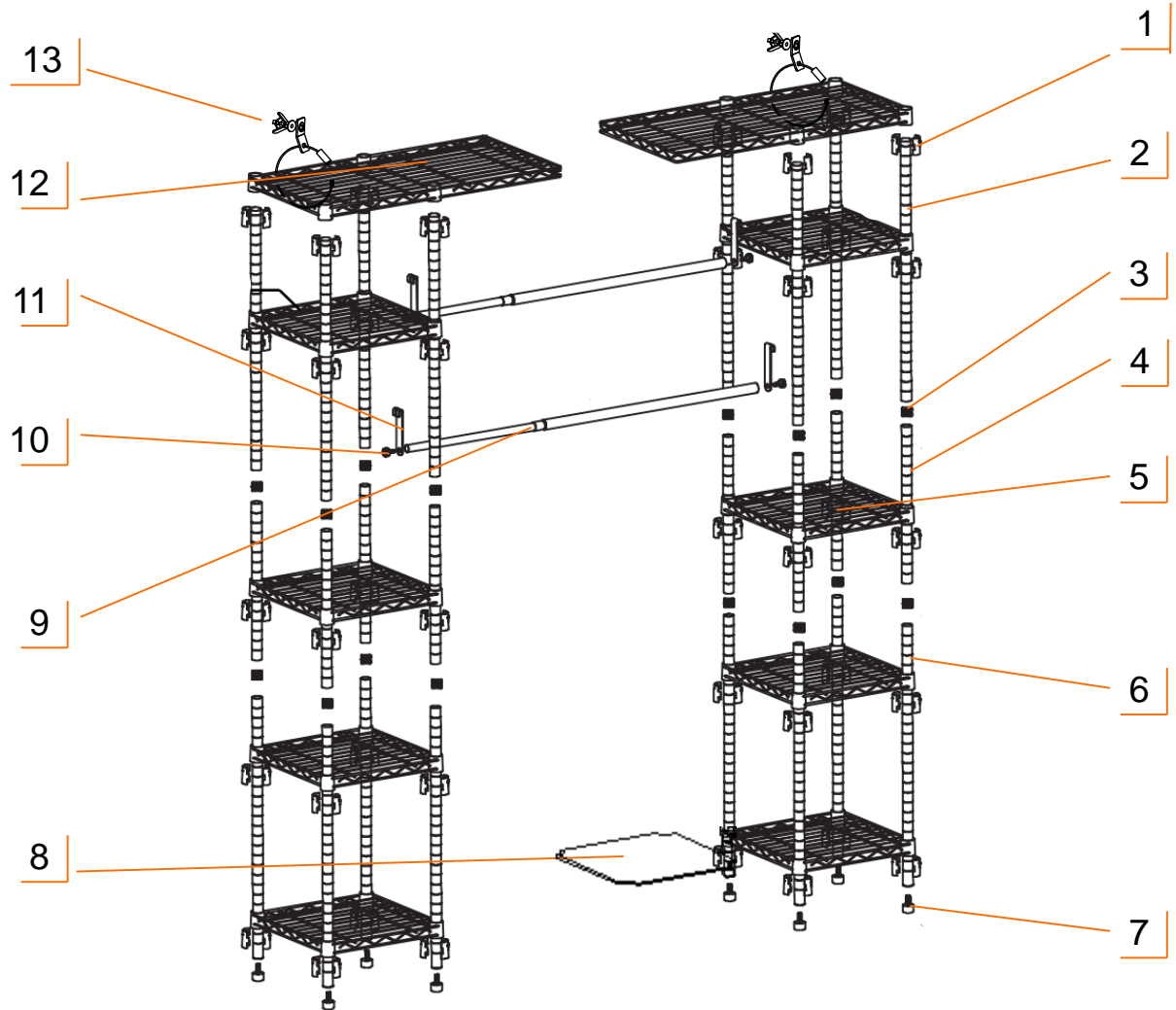



---

## WARNINGS

1. **Read and understand all instructions.** Failure to follow all instructions may result in injury and/or damage.
2. **The warnings, cautions, and instructions in this manual cannot cover all possible conditions or situations that may occur.** The user must always be aware of their environment and ensure that they use the product in a safe and responsible manner.
3. **Do NOT modify the product in any way.** Unauthorized modification may impair the function and/or safety of the product, and may affect the life of the product.
4. **Check for damaged parts.** Before using this product, carefully check that all parts are in good condition, and that the product will operate properly and perform its intended function. Check for damaged parts and any other conditions that may affect the operation of this product. Replace damaged or worn parts, and never use this product with a damaged part.
5. **Do NOT over-expand the product.** Maximum product total width is 78”.
6. **Do NOT expand the product with clothes on it.** Only expand the product when it is empty.
7. **Do NOT overload the product.**

Weight capacity per shelf	30 lb
Total weight capacity per tower	150 lb
Weight capacity per hanging rod (evenly distributed)	125 lb (none expanded) 65 lb (fully expanded)
Total weight capacity per organizer (evenly distributed)	550 lb (none expanded) 330 lb (fully expanded)

---

## CARE AND MAINTENANCE

- Bamboo can be maintained with mineral oil for best results.
- Avoid harsh, abrasive cleaners, and other corrosive chemicals.

# PRODUCT REGISTRATION

Thank you for purchasing a TRINITY Expandable Closet Organizer. In order to register your product and receive streamlined customer service, please fill out the following Product Registration Form and (1) fax the form to 310.347.4134 (2) complete the Product Registration Form online at [www.trinityii.com](http://www.trinityii.com) or (3) scan and email the form to [customerservice@trinityii.com](mailto:customerservice@trinityii.com). Include a copy of your original receipt with your submission.

First Name: \_\_\_\_\_ Last Name: \_\_\_\_\_

Address: \_\_\_\_\_

City: \_\_\_\_\_ State: \_\_\_\_\_ Zip Code: \_\_\_\_\_

Email Address: \_\_\_\_\_ Phone: \_\_\_\_\_

Product Model #: TBFPBR-2701 / TBFZ-2701 Purchase Date: \_\_\_\_ / \_\_\_\_ / \_\_\_\_

Location of Purchase: \_\_\_\_\_

Please rate the importance of each feature (1=least important; 10=most important)

Quality \_\_\_\_ Price \_\_\_\_ Size/Capacity \_\_\_\_ Appearance \_\_\_\_ Other \_\_\_\_

How did you hear about our product?

- Magazine Ad     Catalog     Salesperson     Word of Mouth  
 Internet     Store Display     Other

Marital Status:                       Single                                       Married

Household Income:                 Below \$50,000     \$50,000-\$150,000     \$150,000+

Education:                             High School     College     Graduate School

Primary Residence:                 Own                                       Rent

Comments/Suggestions:

# 1 YEAR LIMITED WARRANTY

## TRINITY Expandable Closet Organizer Model # TBFPBR-2701 / TBFZ-2701

Trinity International Industries (“Trinity”) warrants to the original consumer purchaser (“Purchaser”) of the TRINITY Expandable Closet Organizer (“Product”) that each Product shall be free from defects in workmanship and materials for a period of 1 year from the date of original purchase. Trinity’s obligation under this warranty shall be limited to repair or replacement of, or adequate compensation for the Product which shall not be greater than the amount of the purchase price of the Product, at the option of Trinity, during the warranty period. All replaced parts and Products become the property of Trinity and must be returned to Trinity.

This warranty excludes normal wear and tear of the Product and its parts or components, and damage arising from any of the following: negligent use or misuse of the Product, use contrary to this User’s Manual, or alteration by any one other than Trinity. The warranty period of 1 year shall not be extended or renewed by the repair or replacement of, or compensation for, the Product. Any warranty implied by applicable law is limited in duration to one year from the date of purchase and is subject to the same conditions and limitations as is provided for our express warranty.

Except as set forth herein, and to the extent of applicable there are no warranties on this Product either express or implied, and Trinity disclaims all warranties including, but not limited to, any implied warranties of merchantability, infringement or fitness for a particular purpose. No warranty or guarantee given by any person, firm, or corporation with respect to this product shall be binding on Trinity.

If your Product is defective or otherwise requires service or parts, please call TRINITY Customer Service toll-free at (800) 985-5506, between 8:00 a.m. and 5:00 p.m., PST. Please tell us which model you purchased, the date of the purchase, and the problem with your Product. A copy of your original purchase receipt must accompany your service request.

## LIMITATION OF REMEDIES AND LIABILITY

Trinity (and its employees, officers, members, managers, affiliates and assigns) shall not be liable for any incidental, consequential, special, indirect, remote, special or punitive damages for breach of any warranty, express or implied, including, but not limited to, lost profits, lost savings, loss of anticipated benefits and attorneys’ fees, which arise out of the purchase, use or inability to use the Product, whether arising out of contract, negligence, strict tort, product liability, or any other legal theory on which a claim is based. As noted above, to the extent damages are allowed by our express warranty or by applicable law, those damages may not exceed the purchase price paid for the Product. Without limiting the foregoing Purchaser assumes all risk and liability for loss, damage or injury to Purchaser and Purchaser’s property and to others and their property arising out of the use, misuse, or inability to use this Product. This limited warranty shall not extend to anyone other than the original purchaser of this product, is nontransferable and states your exclusive remedy.

Some states do not allow the exclusion or limitation of incidental, consequential, special, or punitive damages, so the above limitation or exclusion may not apply to you. The above warranty gives you specific legal rights, and you may have other rights which vary from state to state.

---

## CONTACT US

**QUESTIONS? NEED PARTS?  
WE ARE HERE TO HELP!**

**Please feel free to contact us. There are no questions too small, or any problems too big. We're committed to providing our customers with the highest level of service.**

### **TRINITY Customer Service**

**TEL: 800.985.5506**

**FAX: 310.347.4134**

**EMAIL: [customerservice@trinityii.com](mailto:customerservice@trinityii.com)**

**Monday through Friday  
8:00 AM – 5:00 PM (PST)**

**[www.trinityii.com](http://www.trinityii.com)**