

Y2443-75 MARQUE FAUX MARBLE COUNTER BAR TABLE

STEP1

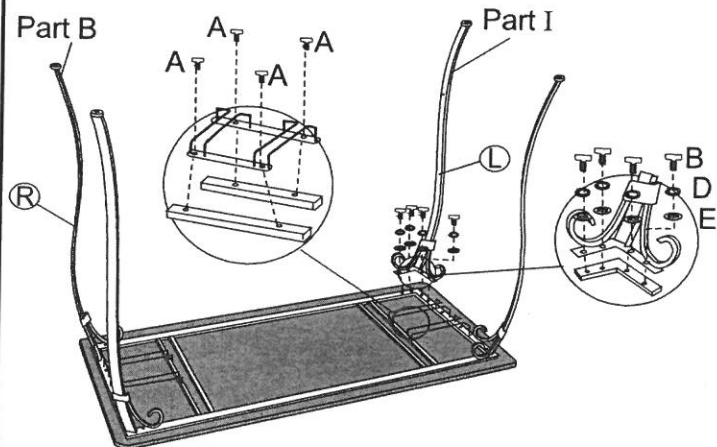

Please put the leg up in the corresponding position as shown.

STEP2

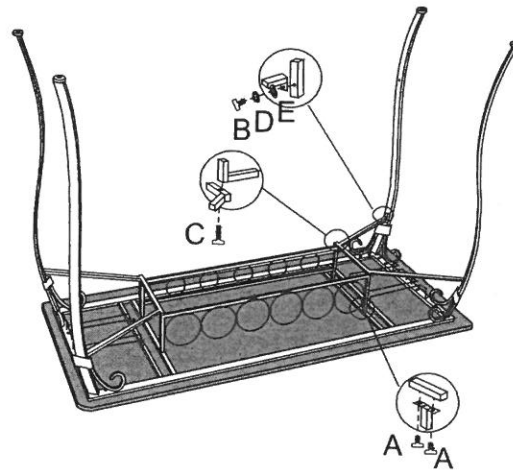



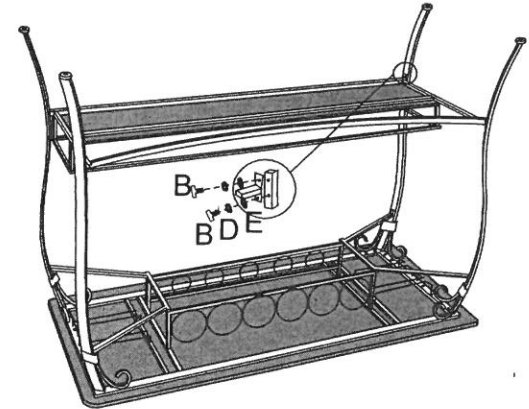



STEP3











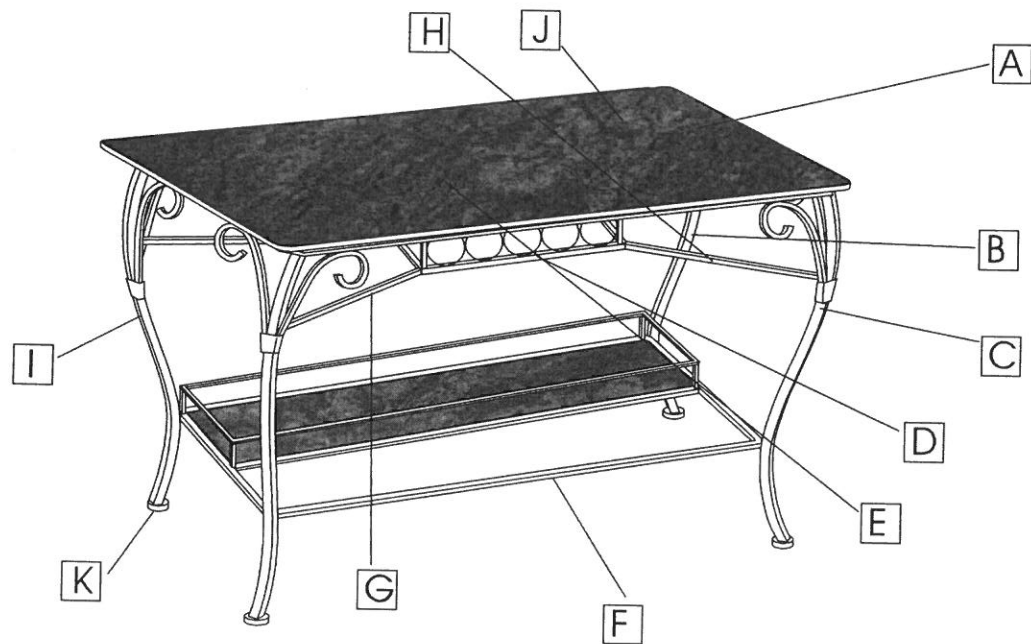

STEP4

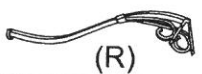

Note: Pls do not tighten all bolts until the products is assembled completely.

A	16X		1/4"*12mm PH
B	28X		1/4"*15mm PH
C	4X		1/4"*25mm PH
D	28X		Φ6.5LW
E	28X		Φ6.5*φ12FW
F	1X		M4



A		1X	G	 (L)	1X
B	 (R)	1X	H	 (R)	1X
C		2X	I	 (L)	1X
D		1X	J		2X
E		1X	K		4X
F		1X			

Y2443-75 MARQUE FAUX MARBLE COUNTER BAR STOOL

STEP1

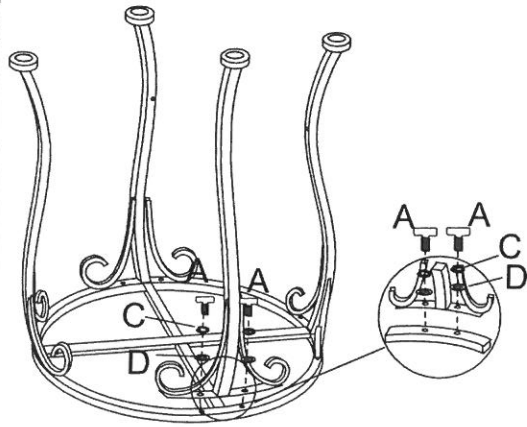

STEP2

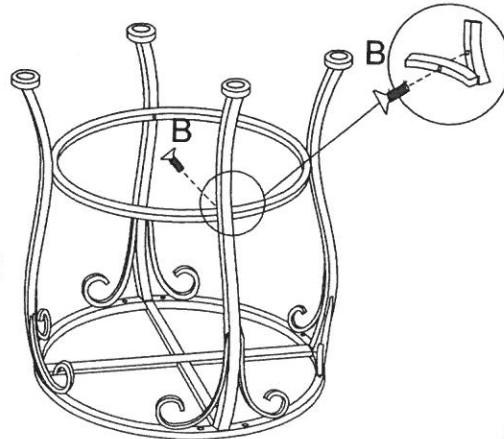

STEP3

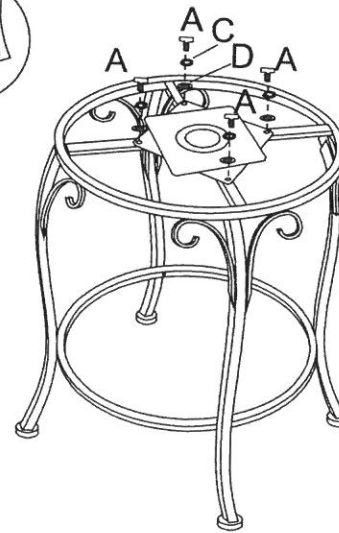

STEP4

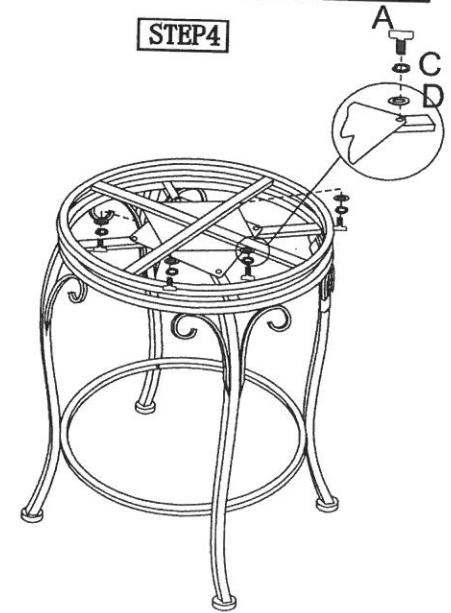



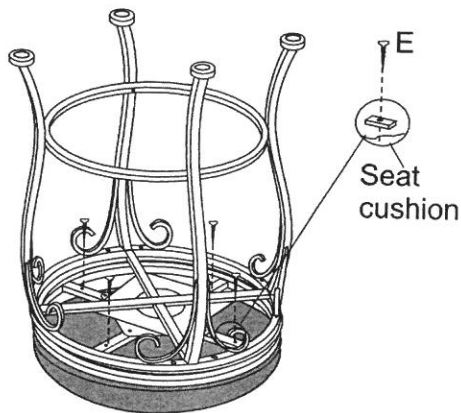



STEP5

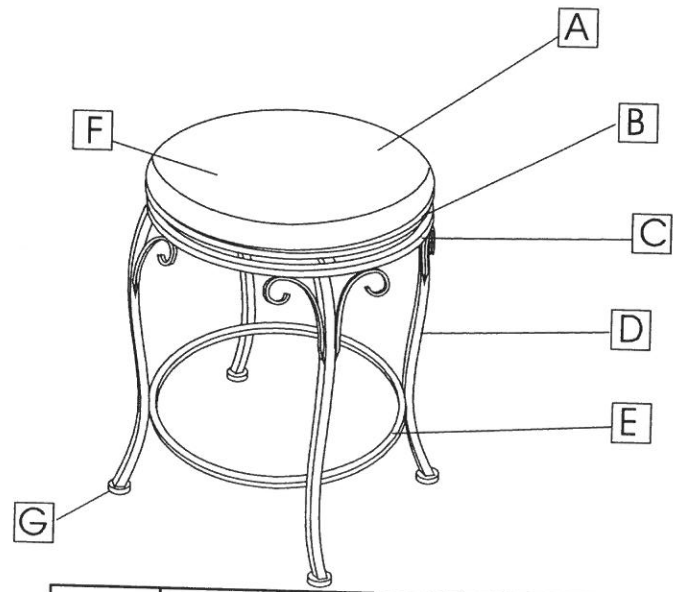

Note: Pls do not tighten all bolts until the products is assembled completely.

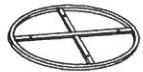
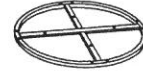
A	16X		1/4"*15mm PH
B	4 X		1/4"*25mm PH
C	16X		Φ6.5LW
D	16X		Φ6.5*φ12FW
E	4 X		M4*28mm
F	1 X		M4



A		1X
B		1X
C		1X
D		4X
E		1X
F		1X
G		4X