

# Assembly Instruction

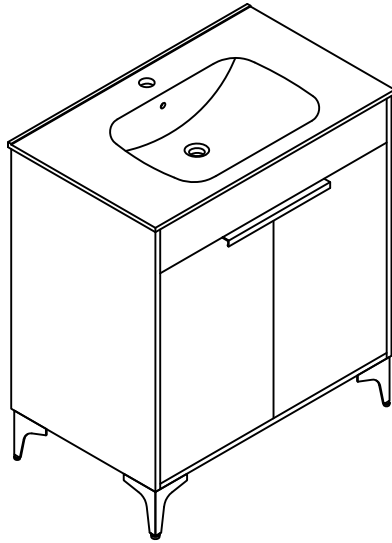

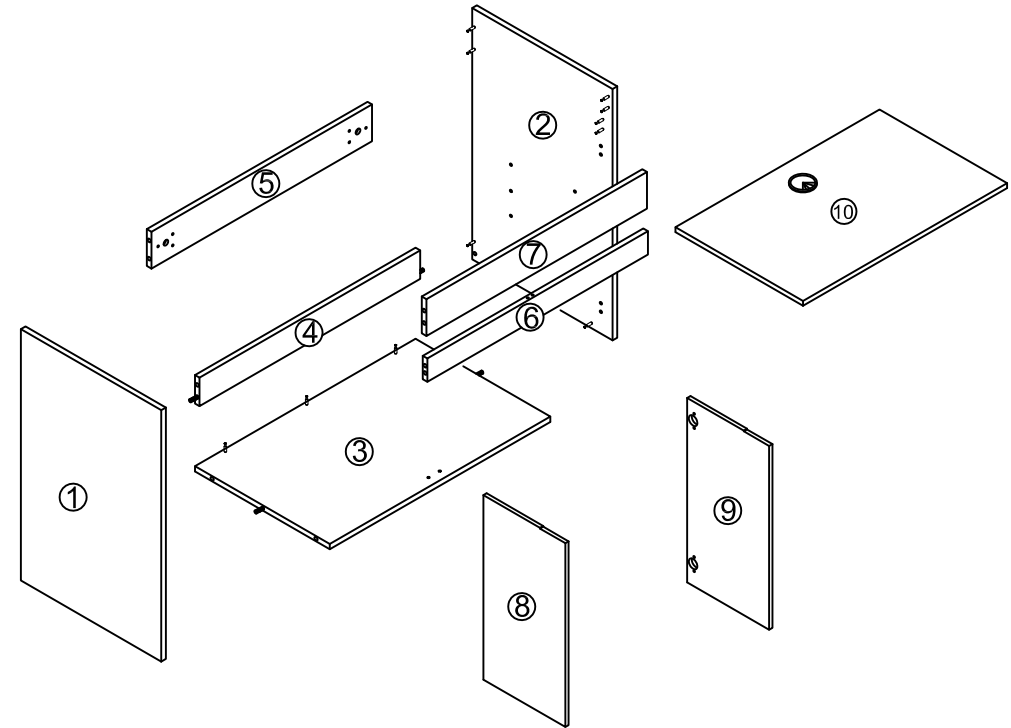





Item No.:500604-24  
500604-30  
500604-36









# Components

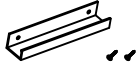

## Hardware

NO.	Draw	QTY
A	 Screws Ø4x14mm	48
B	 Two-in-one connector	21
C	 Two-in-one connector	21
D	 Wood plug	4
E	 Bracket (53x70x44mm)	2
F	 Plastic anchor(Ø10mm)	2
G	 Screws for fix on the wall	2
H	 Door stopper	2
I	 Bracket (19x19x35mm)	3

NO.	Draw	QTY
J	 Hinges	4
K	 Handle ( Screws Ø4x14mm)	2
L	 Movable laminate support	4
M	 Metal Feet	4
N	 Screws M4x14mm	16
O	 Anti-collision gasket	2
P	 Screwdriver	1

## Recommended tools You Will Need-Outils Requis

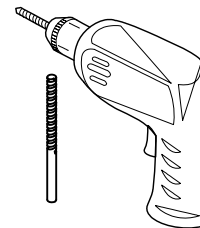

Power drill

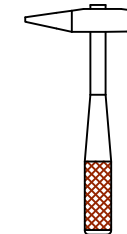

Hammer



Silicone

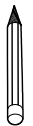





Pencil

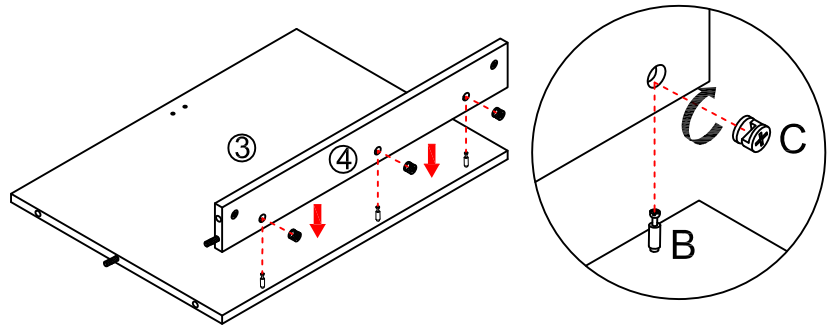

Screwdriver

### Step 1



-  x3
-  x3
-  x1

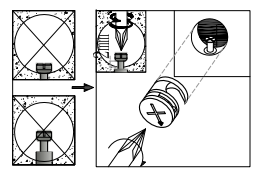

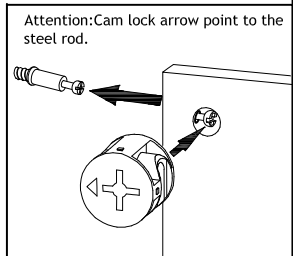

Notes: Screw installation depth as shown



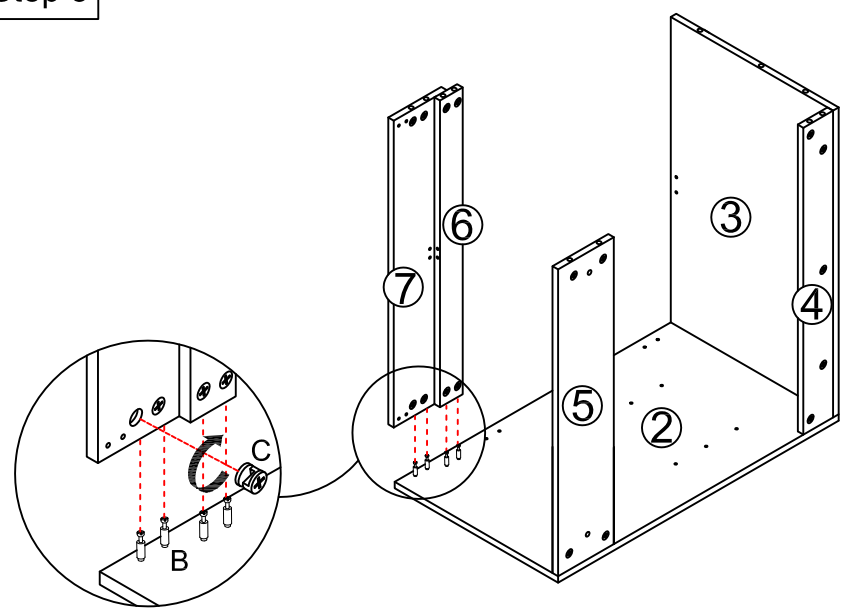



### Step 3

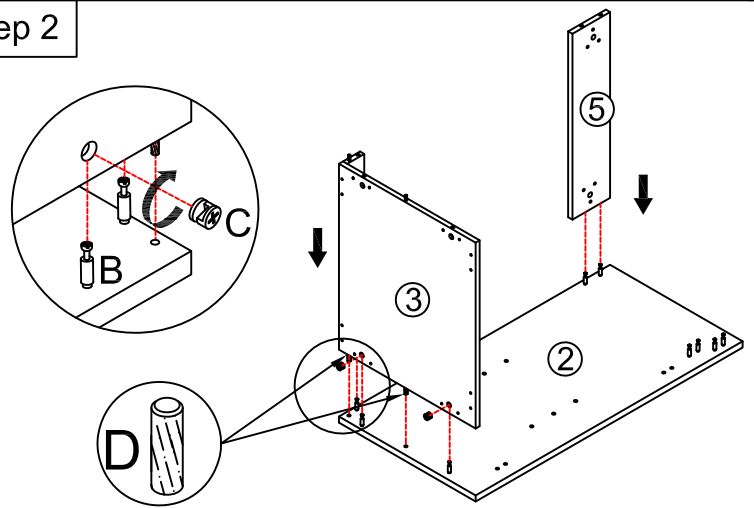

-  x4
-  x4
-  x1

### Step 2



-  x5
-  x5
-  x2
-  x1

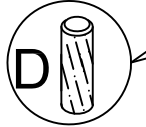



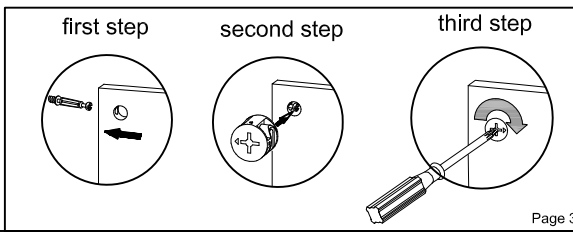
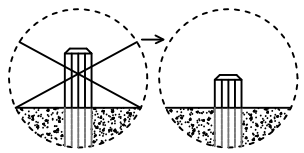

Note: The D parts are used for these two holes

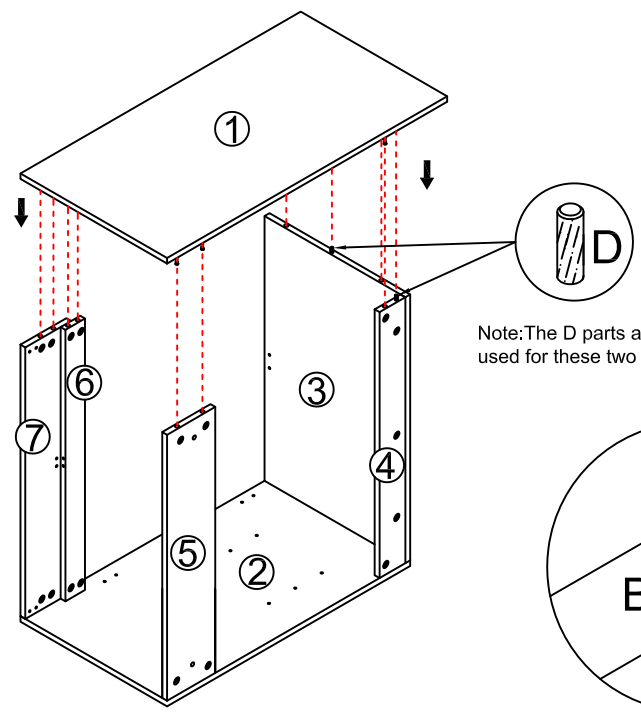

### Step 4



-  x9
-  x9
-  x2
-  x1

Note: The D parts are used for these two holes

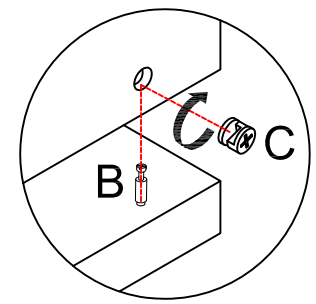

Step 5

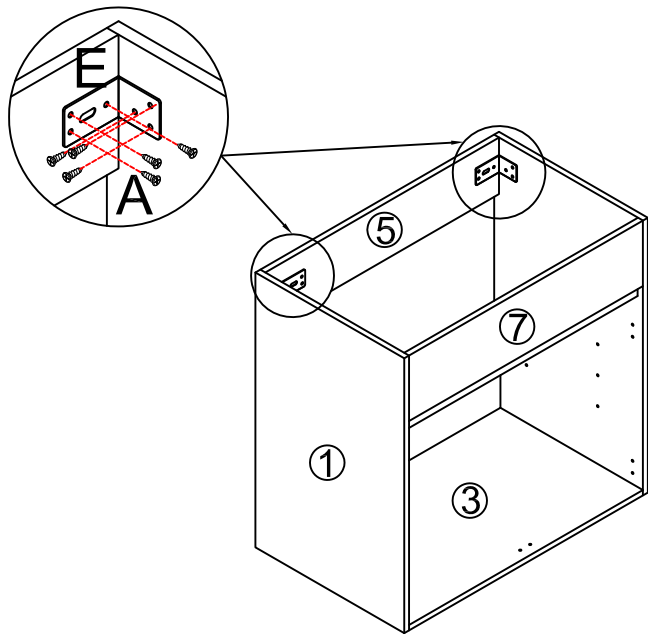

x2

E

(∅4 x 14mm)



x12

A



Tool

Step 7

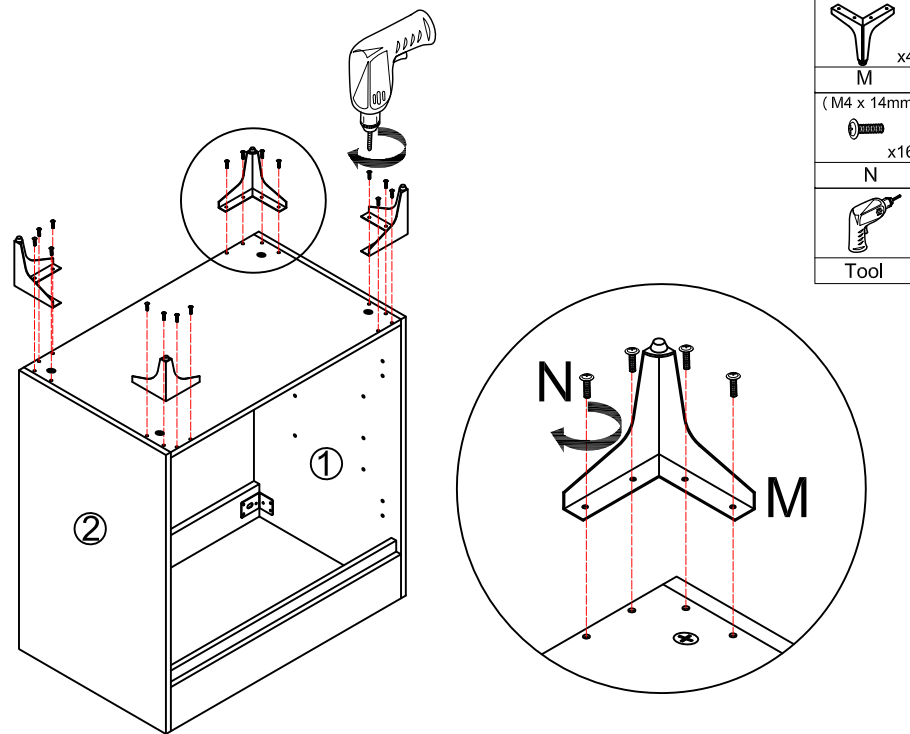

x4

M

(M4 x 14mm)



x16

N



Tool

Step 6

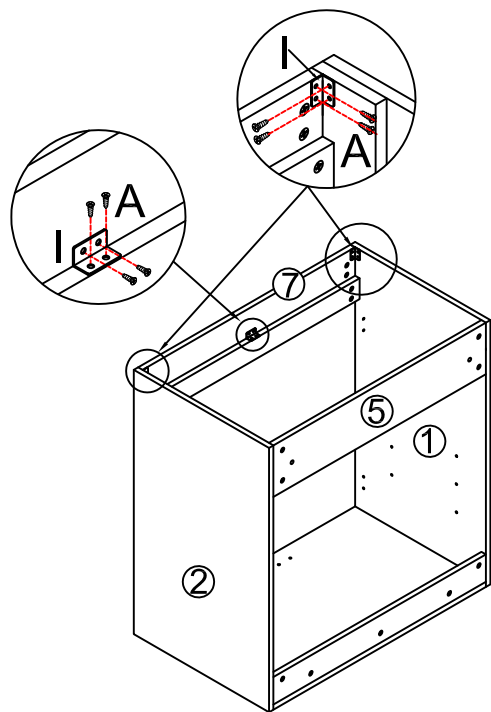

x3

I

(∅4 x 14mm)



x12

A



Tool

Step 8

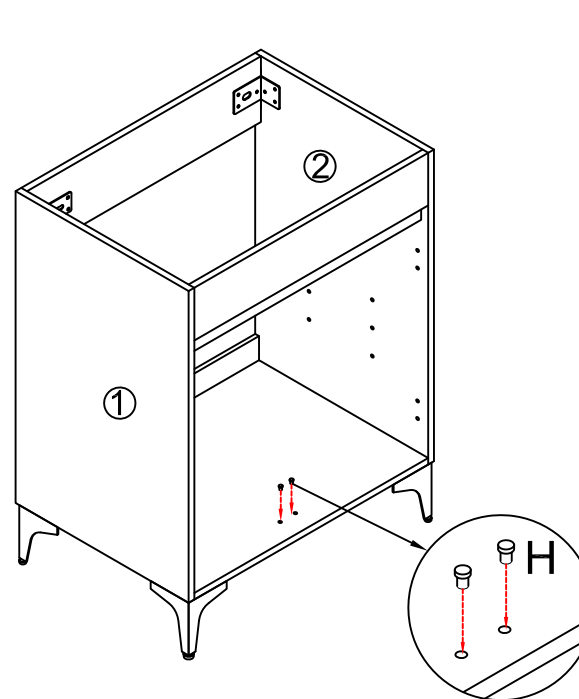



x2

H

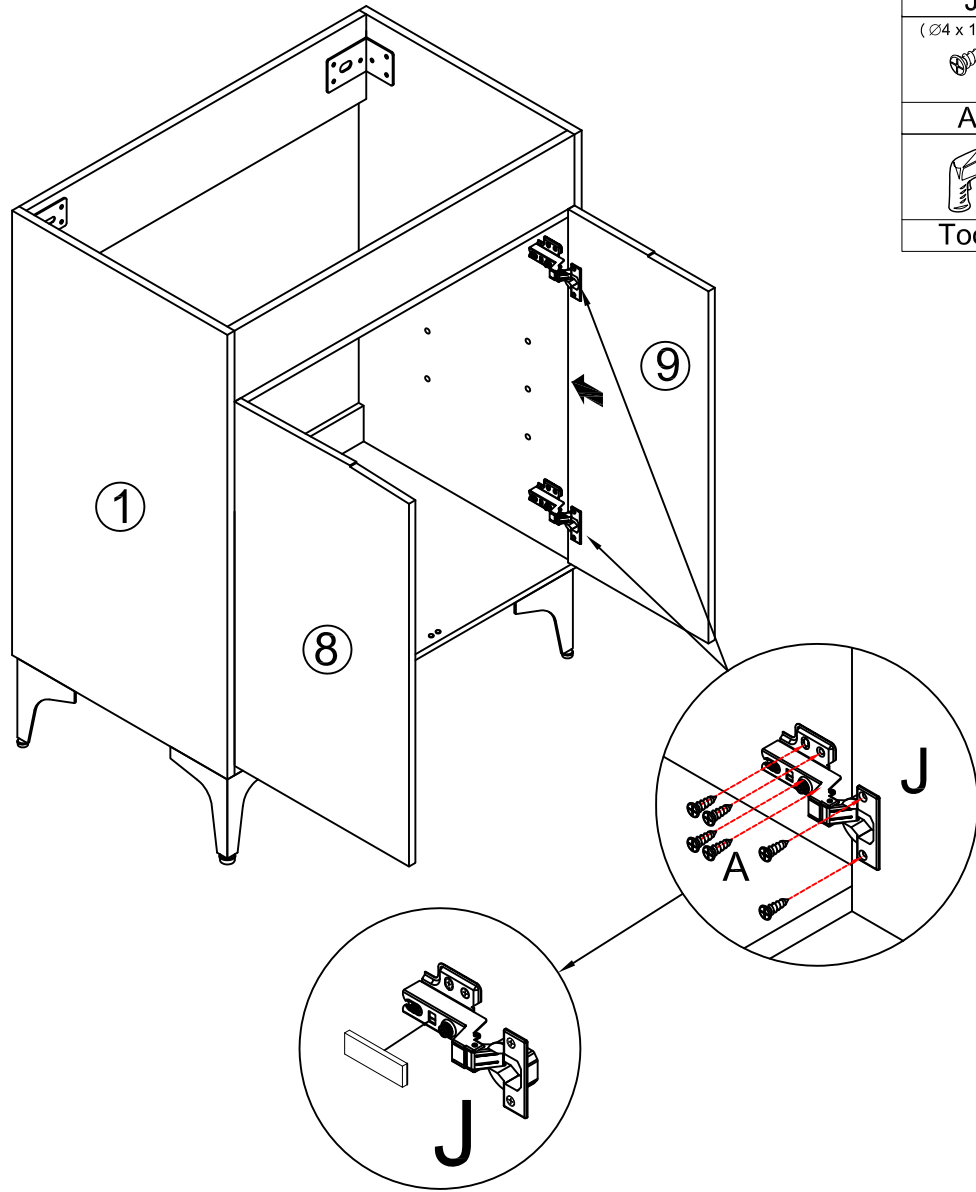

Step 9

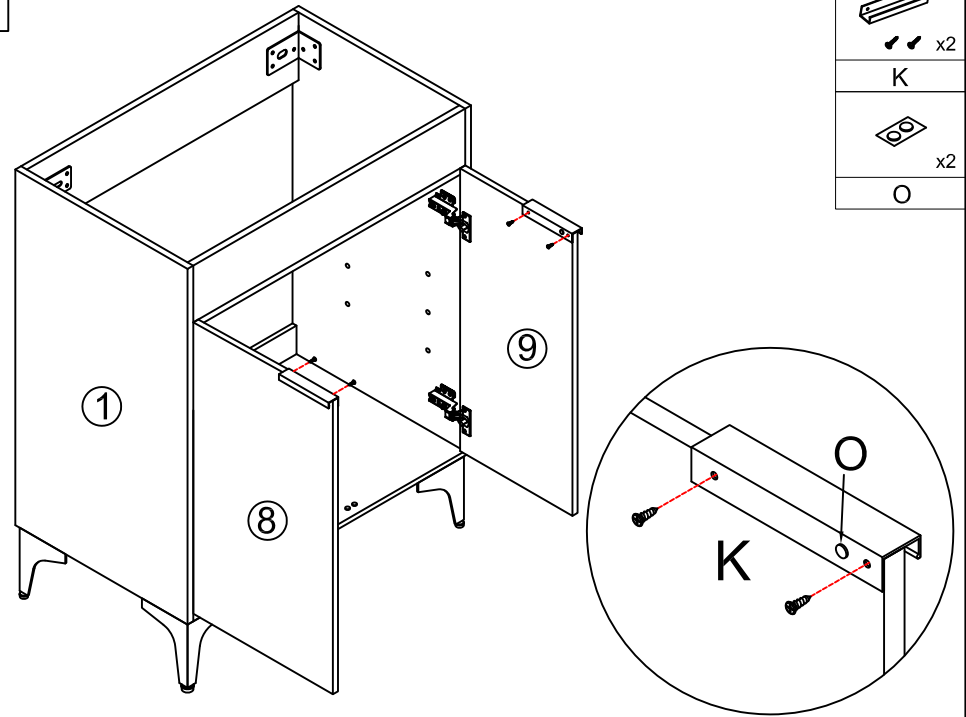

-  x4
- J  
(∅4 x 14mm)
-  x24
- A
- 
- Tool

Step 10



-  x2
- K
-  x2
- O

Step 11

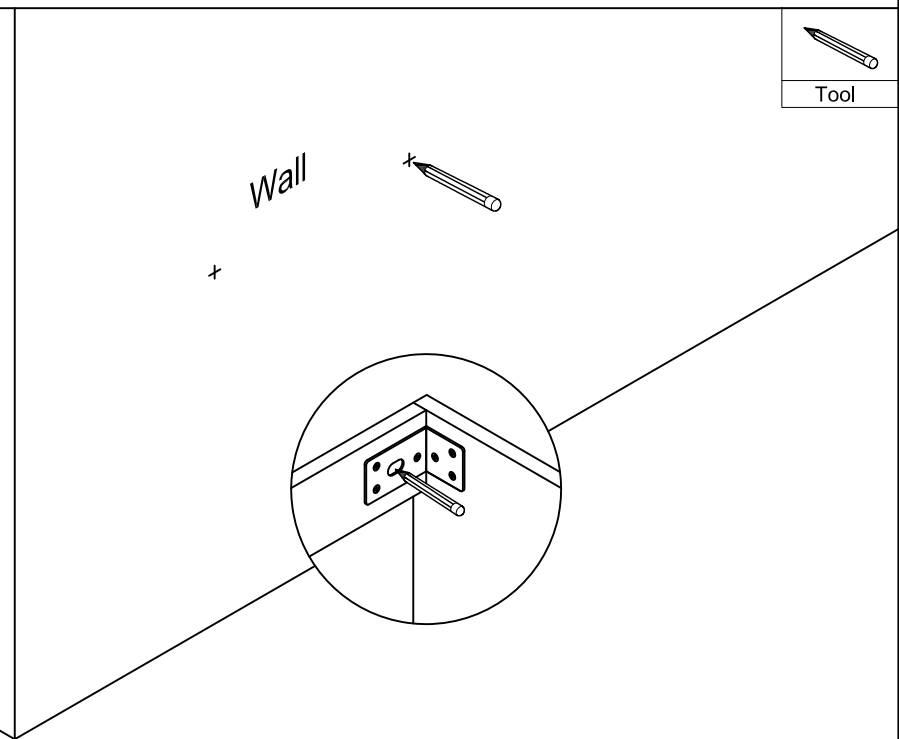

- 
- Tool

You can adjust the doors by tightening or loosening the screws on the hinge. →

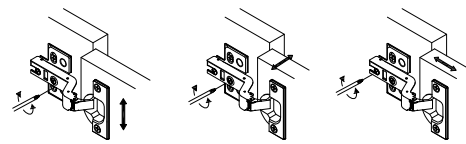

Step 12

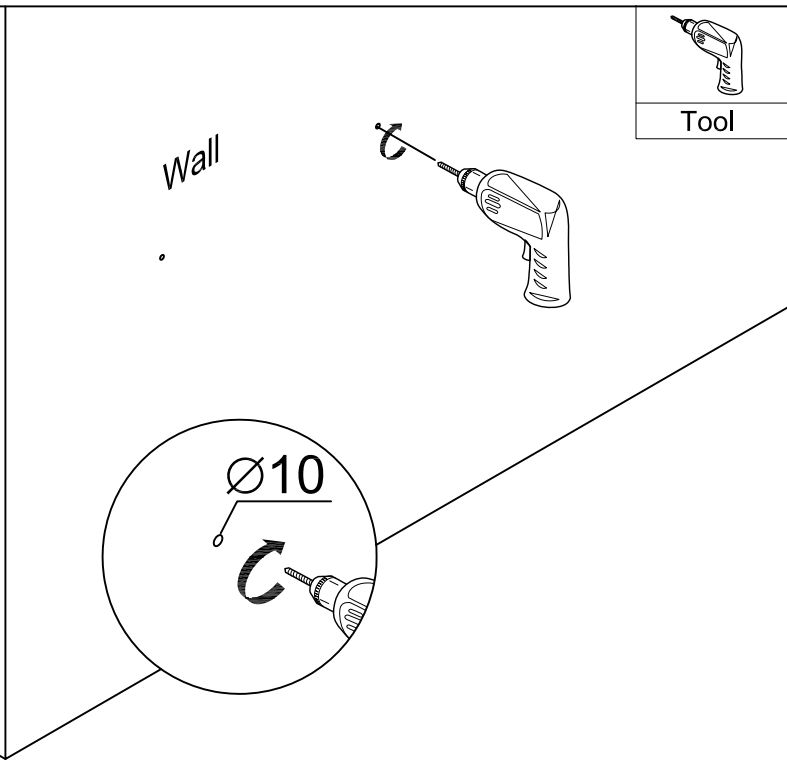

Step 14

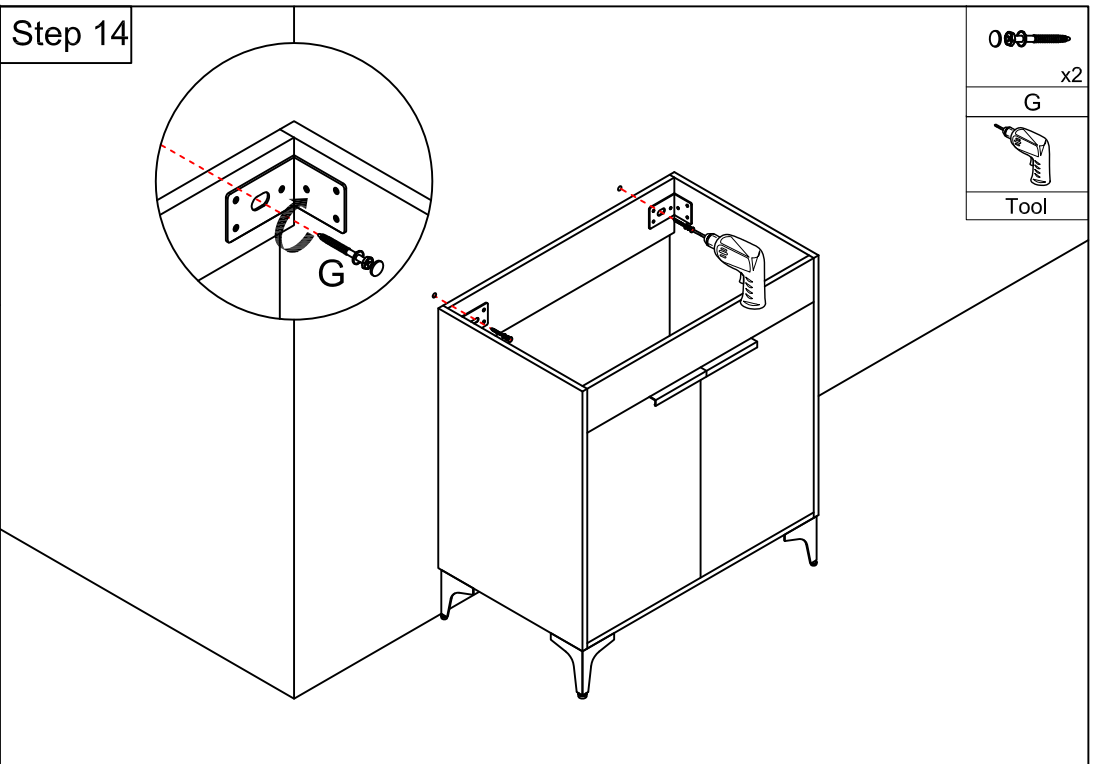

Step 13

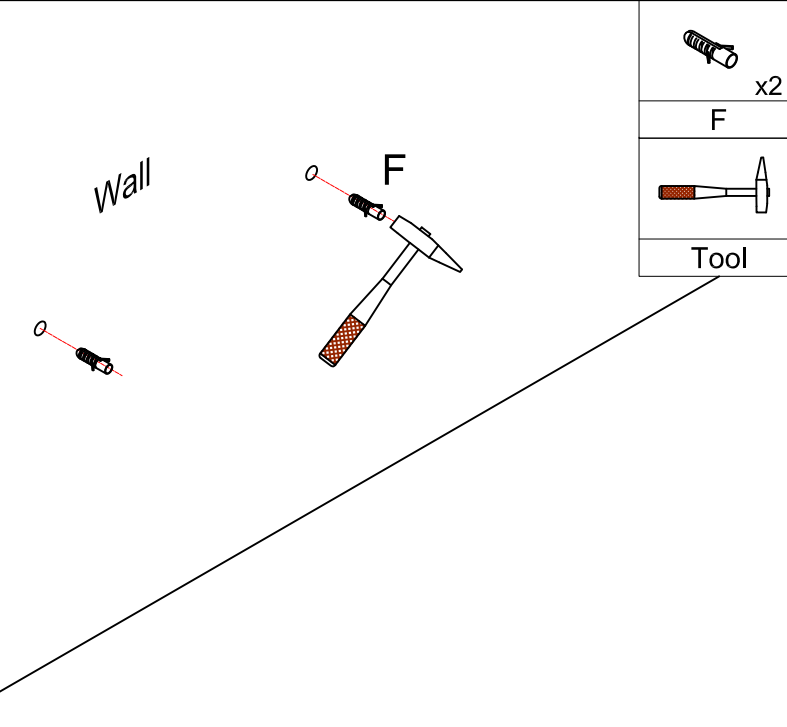

Step 15

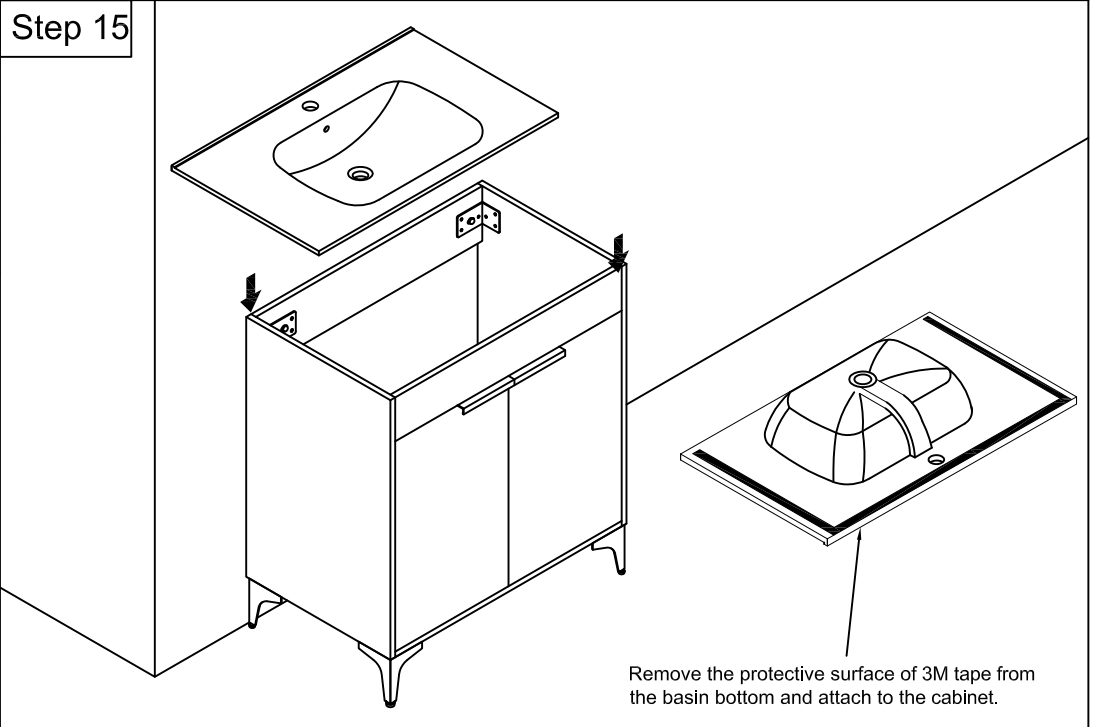

Step 16

 x4  
L

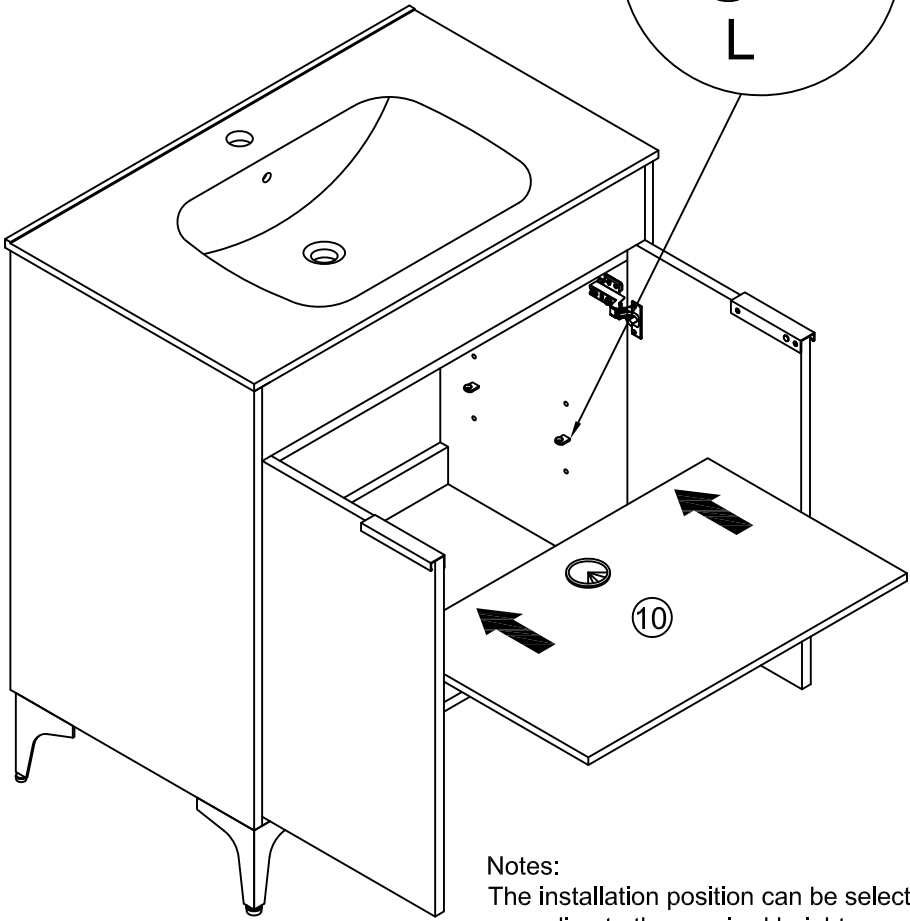
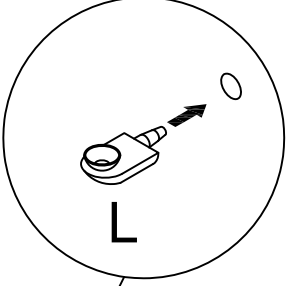

Notes:  
The installation position can be selected according to the required height.

Finished

