

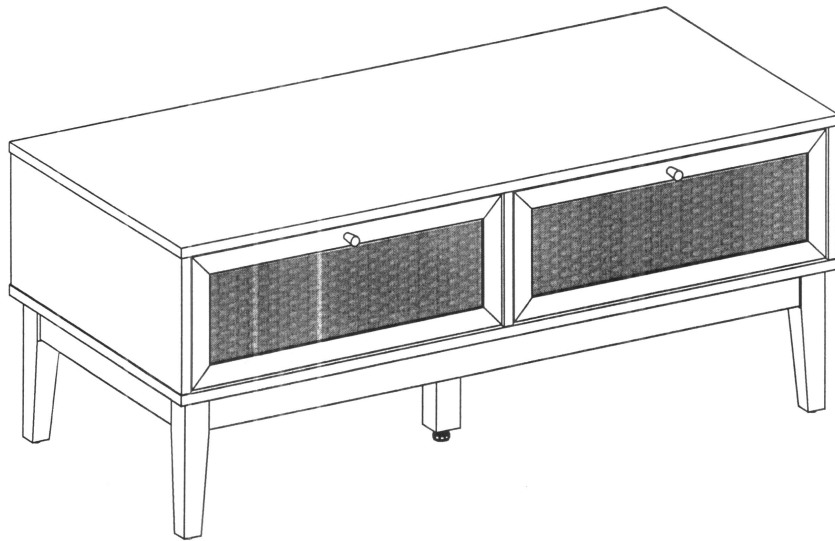

# BODRUM COFFEE TABLE

## CT-4320



		
<b>45 Minutes</b>	<b>2 People</b>	

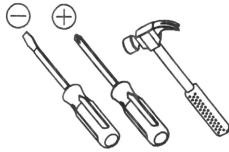
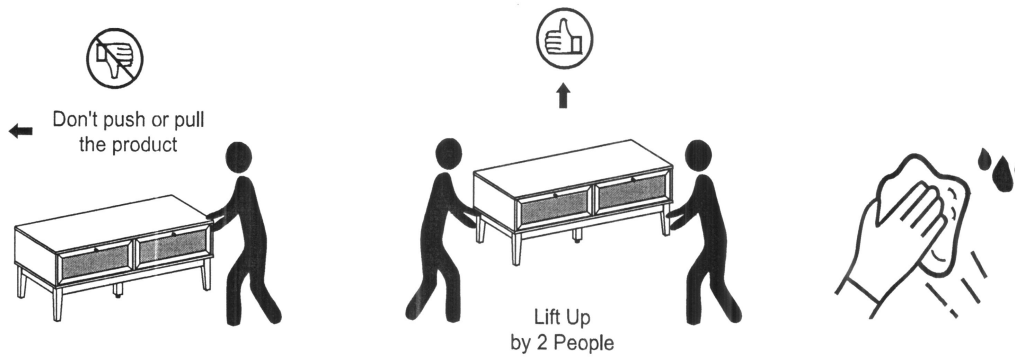
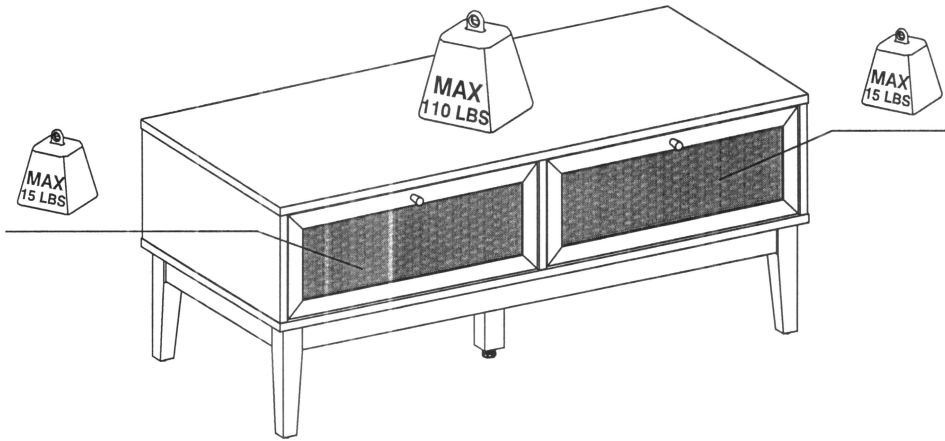

1. The load in the illustration in the **PRODUCT INFORMATION** section is a load at rest with an even distribution on all surfaces.
2. Move this product by lifting, do not push because it can damage the legs.
3. When exposed to liquid, immediately clean using a soft cloth.
4. Do not place high temperature objects without using a base.
5. The surface of the product should not be exposed to chemical liquids. Example: thinner, nail polish.
6. Cleaning the product is enough with a dry cloth, but if necessary, you can use a damp cloth instead of a wet one.
7. Do not climb or hang on drawers, doors or shelves.
8. Surface lamination using Paper base material.
9. Do not place hot objects directly on the surface. Always use a heat sink. There is a risk of surface bubbles due to physical contact with hot objects due to evaporation of the adhesive layer between the wooden planks and the laminate layer.
10. Do not place wet objects directly on the surface. Always use a mat so that the surface does not come into contact with liquid. There is a risk of surface discoloration and coating becoming weathered due to physical contact with wet objects.

# PARTS LIST

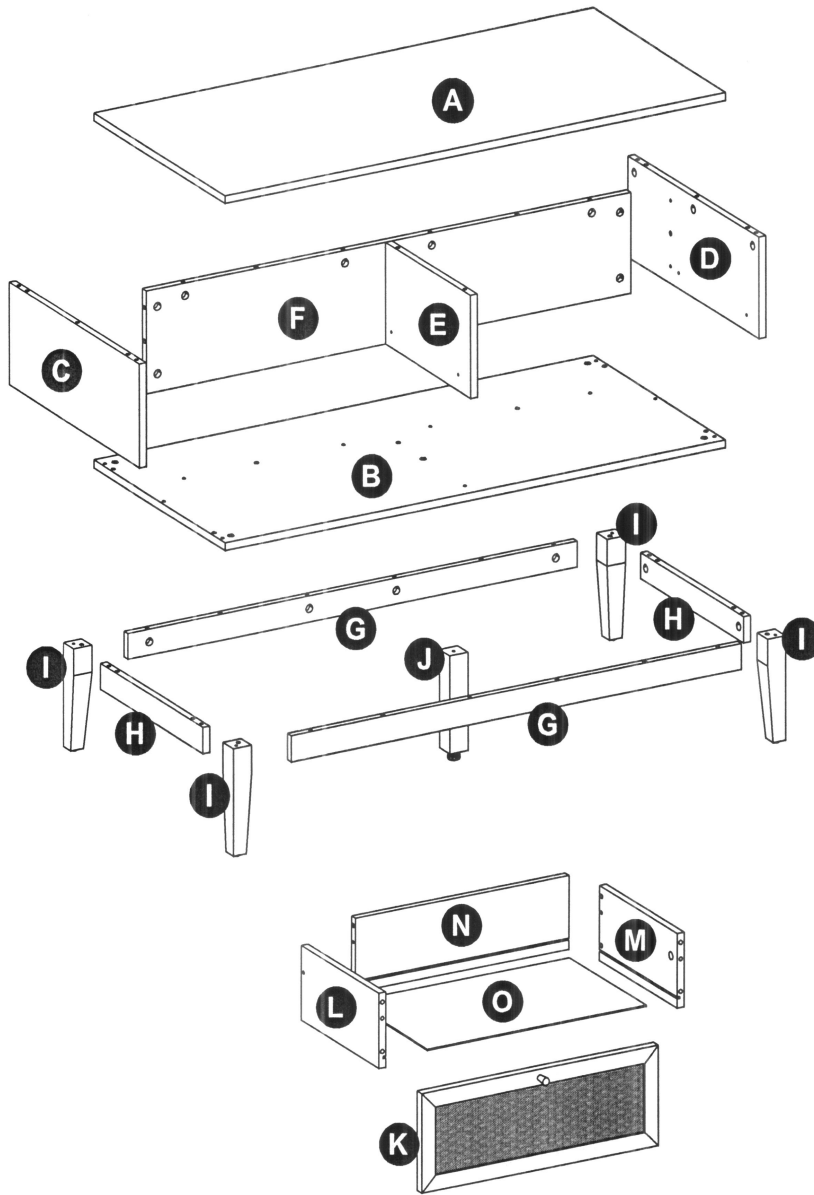

X2

No.	Size	Qty
A	1100 x 500 x 15 mm	1
B	1100 x 500 x 15 mm	1
C	196 x 496 x 15 mm	1
D	196 x 496 x 15 mm	1
E	196 x 325 x 15 mm	1
F	1067 x 196 x 15 mm	1
G	990 x 50 x 15 mm	2

No.	Size	Qty
H	390 x 50 x 15 mm	2
I	200 x 40 x 40 mm	4
J	188 x 40 x 40 mm	1
K	520 x 190 x 18 mm	2
L	296 x 146 x 15 mm	2
M	296 x 146 x 15 mm	2
N	471 x 144 x 15 mm	2
O	482 x 292.5 x 2.5 mm	2

# HARDWARE LIST

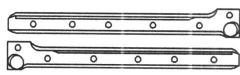
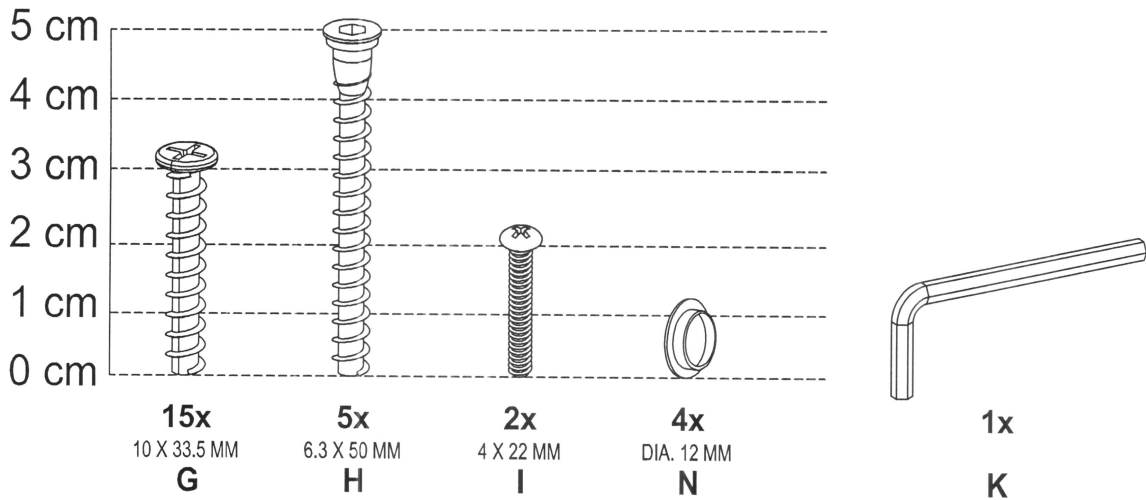
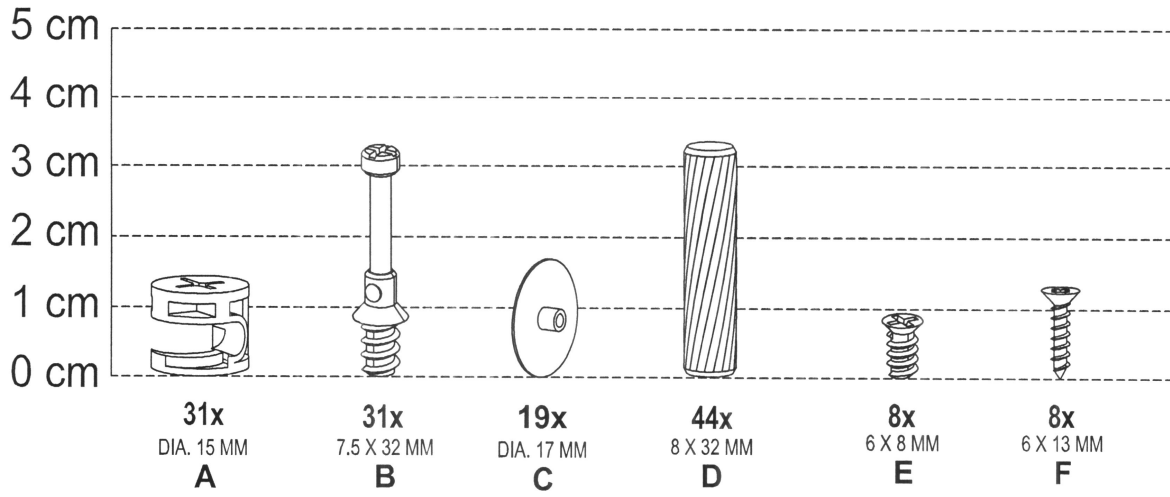

2x  
L

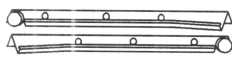

2x  
M

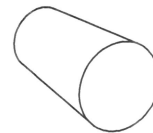

2x  
J

1



B x 23

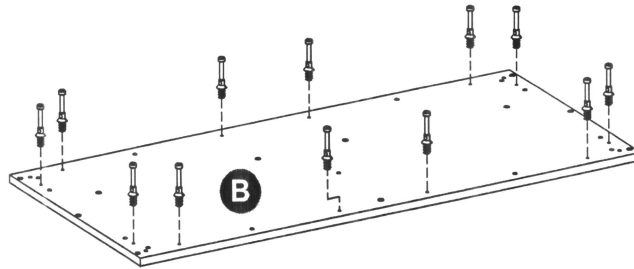
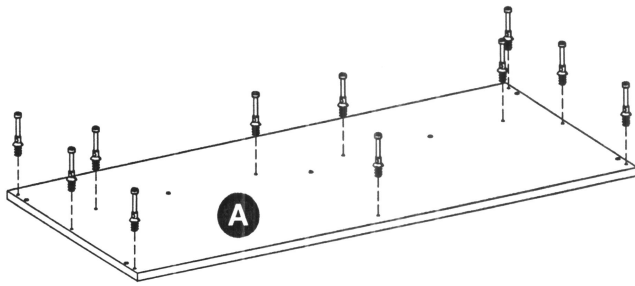

2



B x 4



D x 8





E x 4

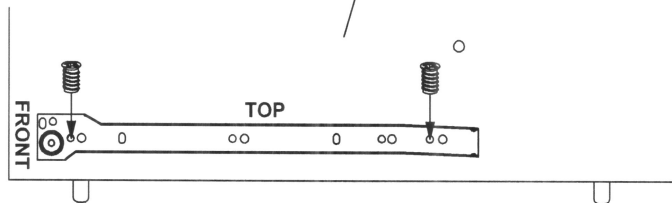
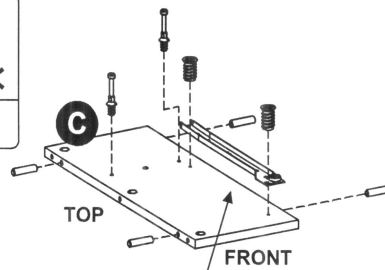
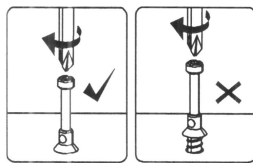
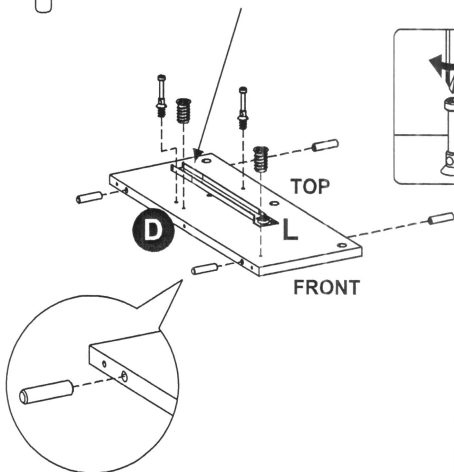
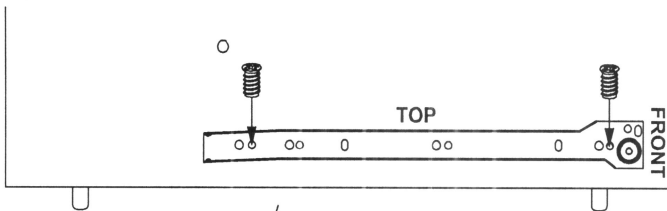

L x 1



3

		
D x 6	E x 4	L x 1

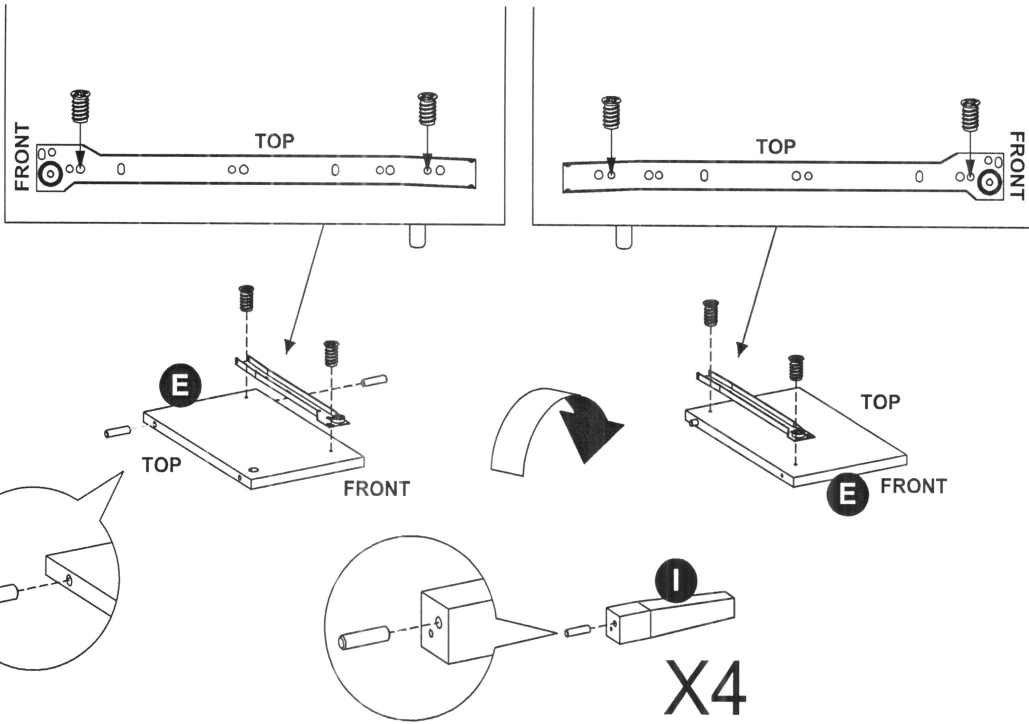

4

D x 14

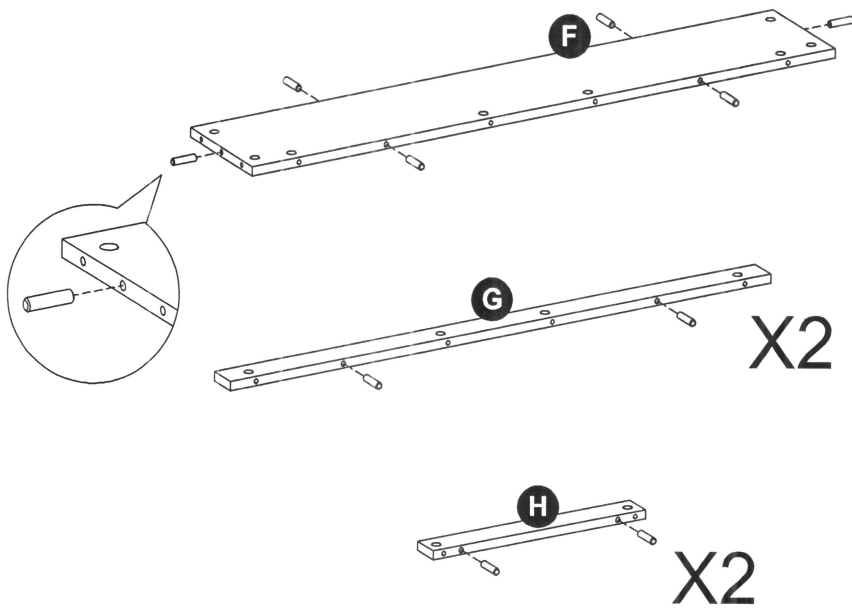

5



A x 4

C x 4

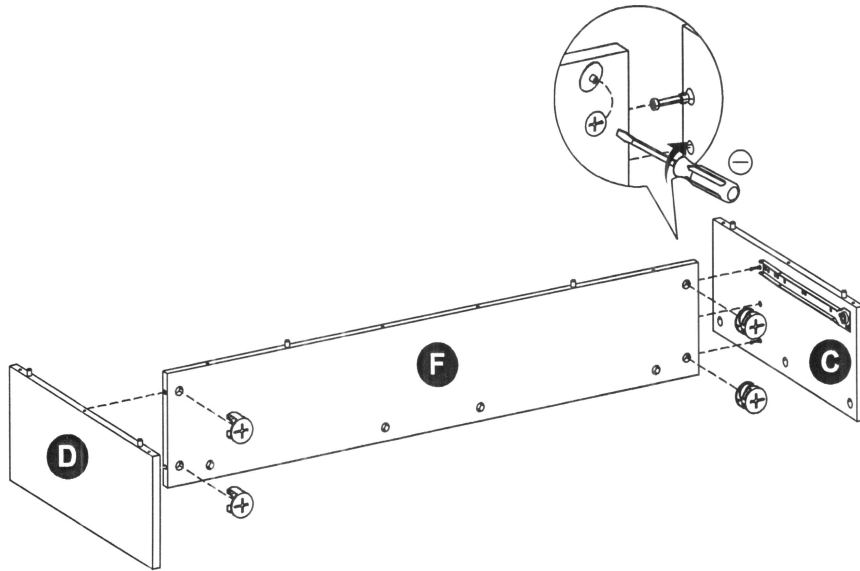

6



A x 10

C x 10

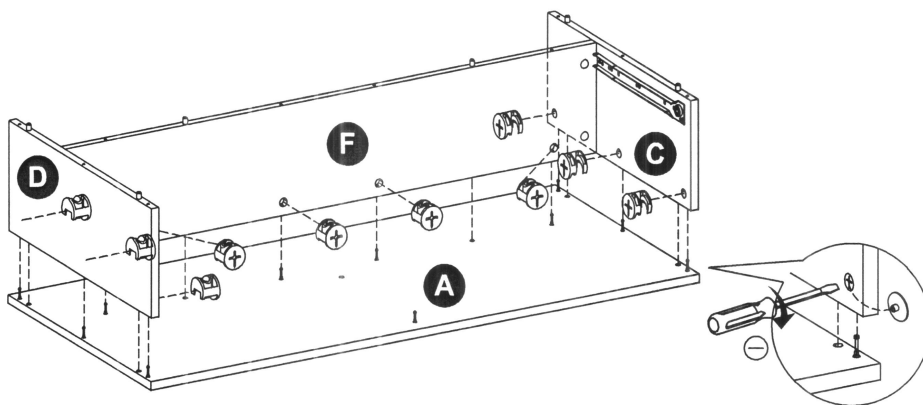

7



A x 1



C x 1

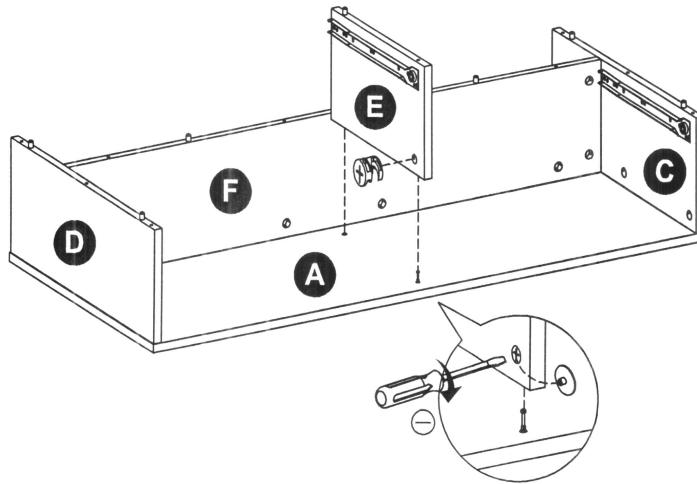

8



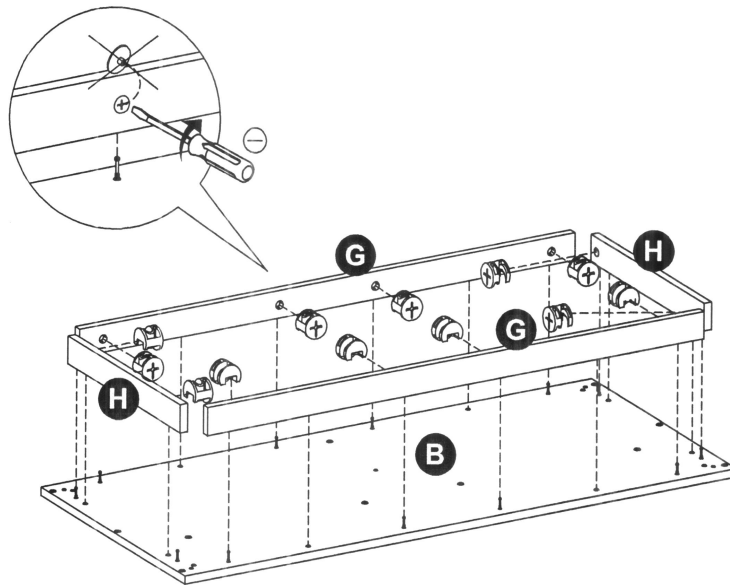

A x 12





9

	
H x 5	K x 1

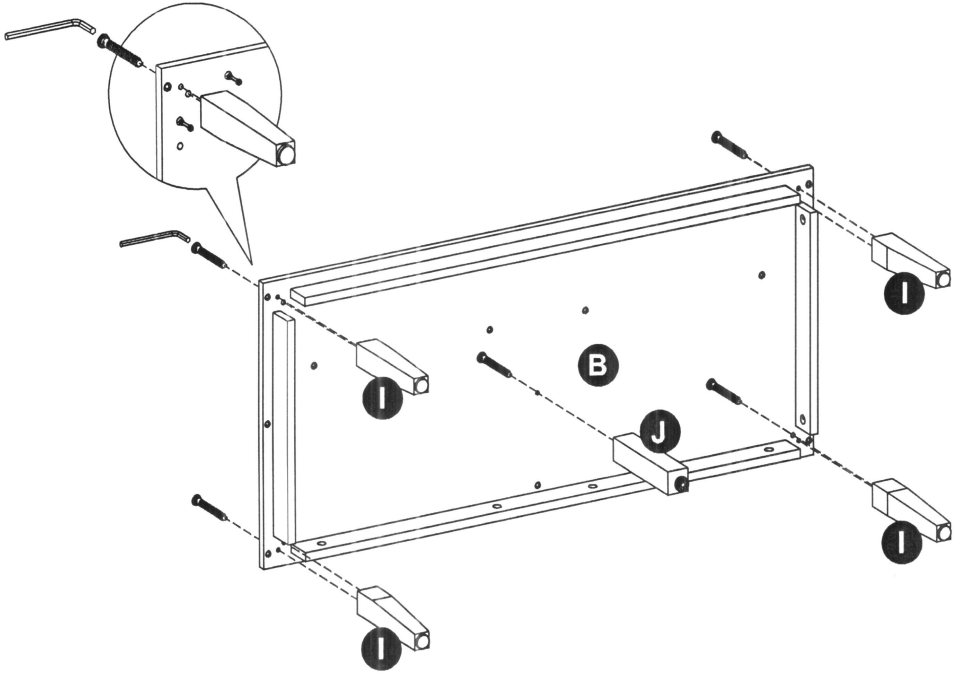

10

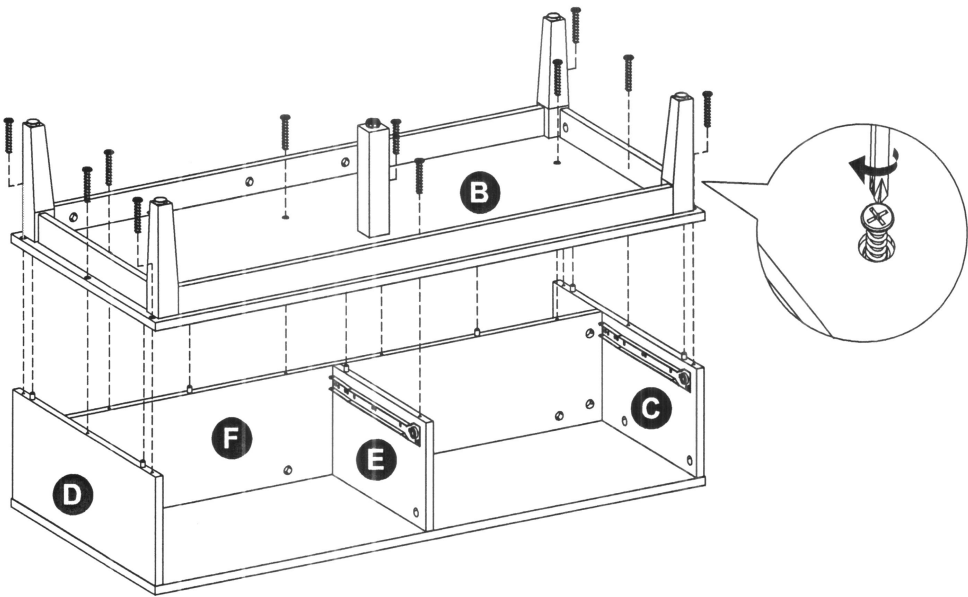

G x 11



11

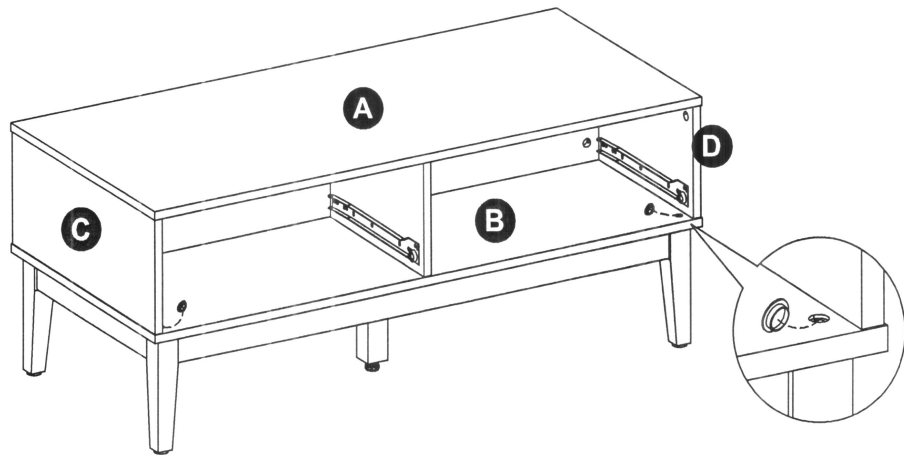

N x 4



12

B x 4	D x 16	I x 2	J x 2

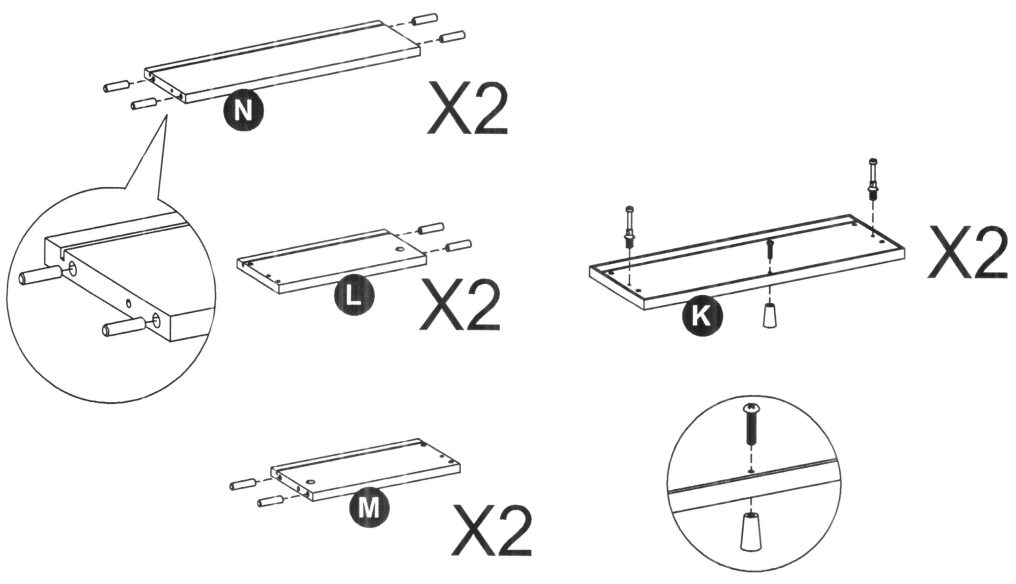

13

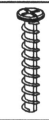

G x 4

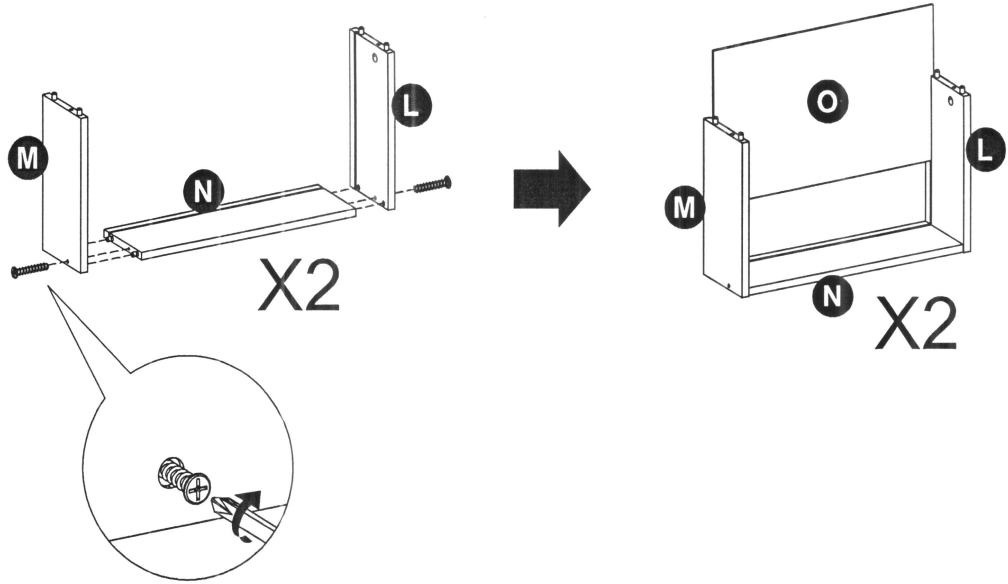

14



A x 4



C x 4

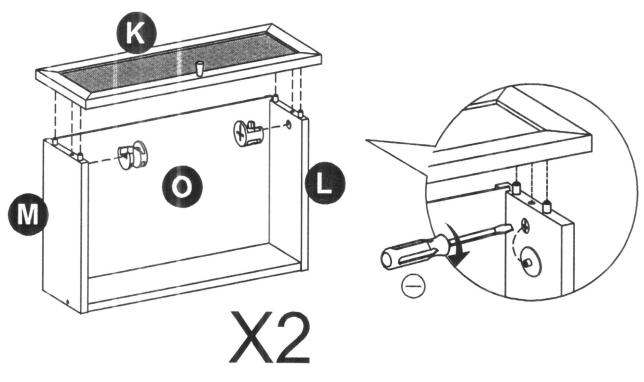

15

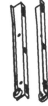
	
F x 8	M x 2

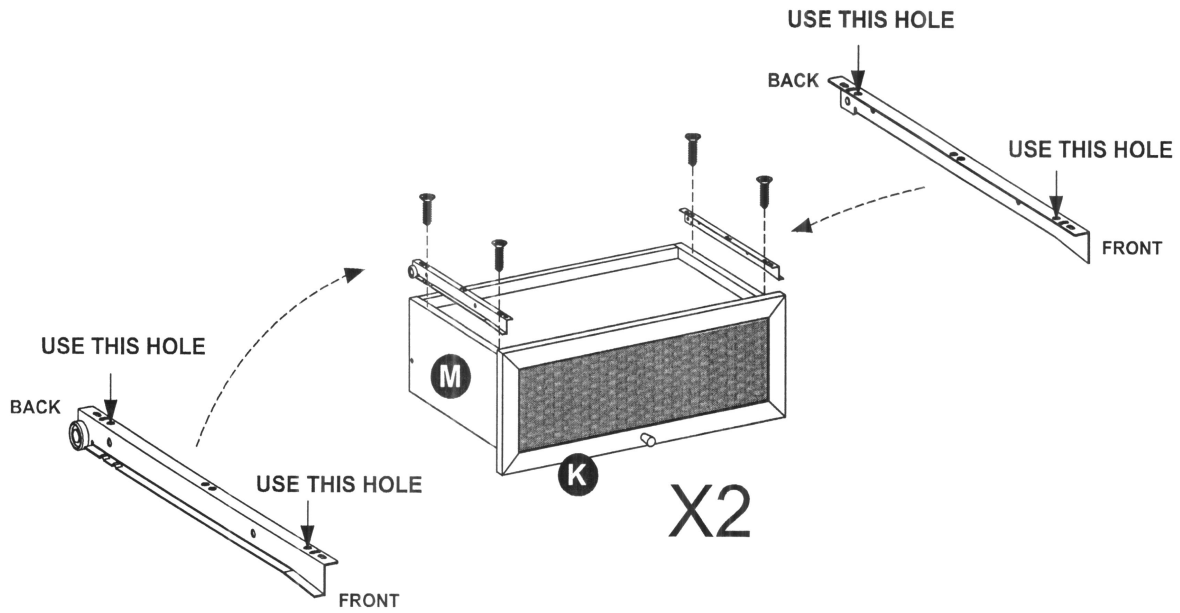

16

