

SimplyShade™

Fiji *Cantilever*

11.5' Octagon / SSAG25R

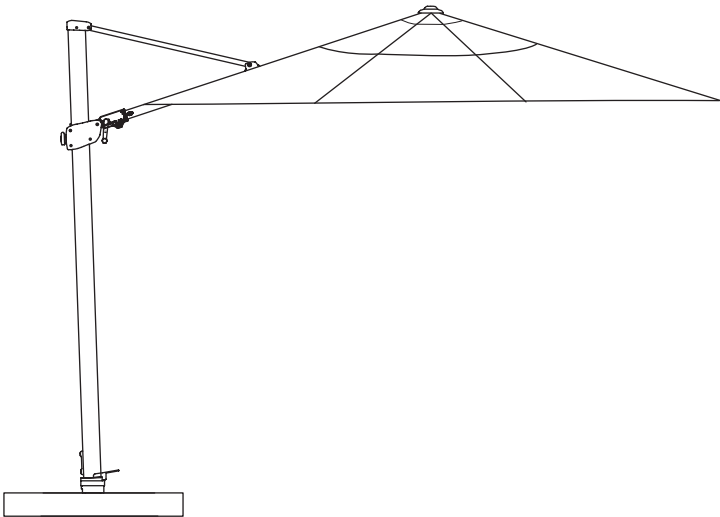

Instruction Manual

Thank you for purchasing SimplyShade's Fiji Cantilever Umbrella.

Please remove all contents from the package, inspect and review checklist.

CAUTION: To reduce personal injury and damage to your umbrella, read and follow this assembly and operation guide. We recommend a two-person team for assembly and disassembly. *Save information for future reference.*

CHECKLIST

- A - Canopy
- B - Finial
- C - Tilt Mechanism
- D - Crank Handle
- E - Adjustment Knob
- F - Main Frame
- G - Rotation Hub
- H - Hardware
- I - Base (sold separately)

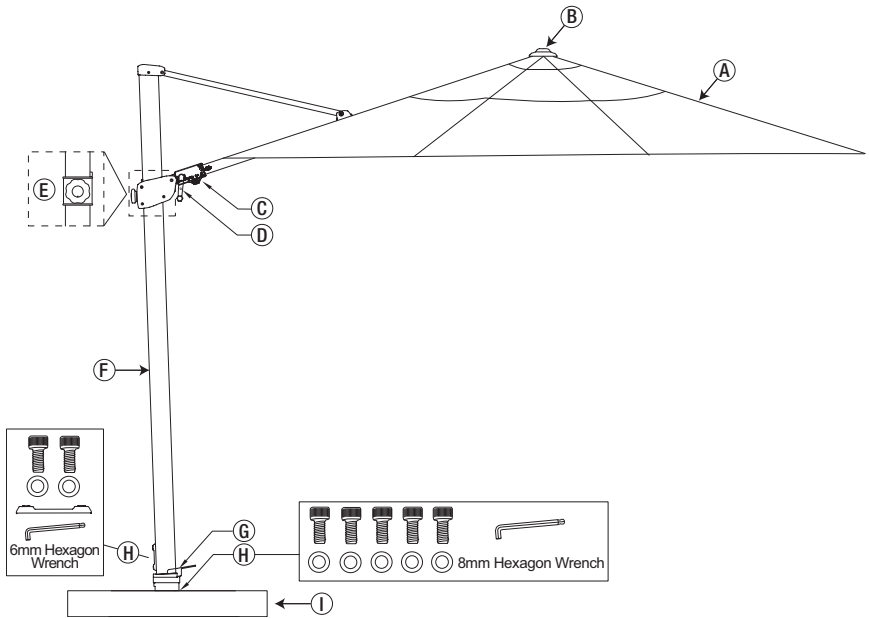

NOTE: REFER TO SEPARATE MOUNT KIT OR BACARA BASE MANUAL FOR BASE ASSEMBLY PRIOR TO PROCEEDING.

STEP 1 Rotating Hub Assembly

If you have already installed your rotating hub onto your base, please skip to Step 2.

Remove rotating hub from the main frame by removing the (2) main frame bolts and (2) washers (Fig. 1), set aside bolts for later use. Now, place rotating hub on base plate (if installing onto mount kit) or inverted plate (if installing onto Bacara base) (Fig. 2) and tighten with (5) supplied hub bolts and washers (Fig. 3). Bacara base assembly example shown below.



(Fig. 1)

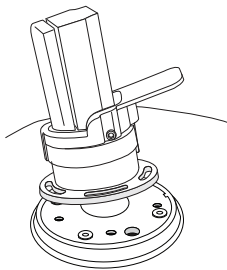

(Fig. 2)

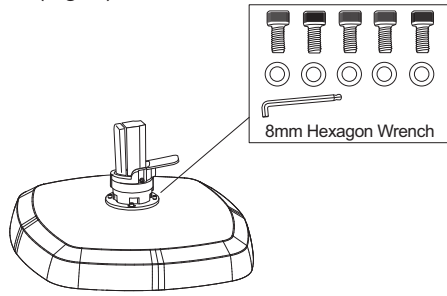

(Fig. 3)

STEP 2 Umbrella Assembly



NOTE: Two persons may be needed for the following action.

Lift umbrella up and insert the main frame rotation hub (Fig. 4). Secure into place by inserting (2) bolts and (2) washers and tighten using 6mm hexagon wrench.

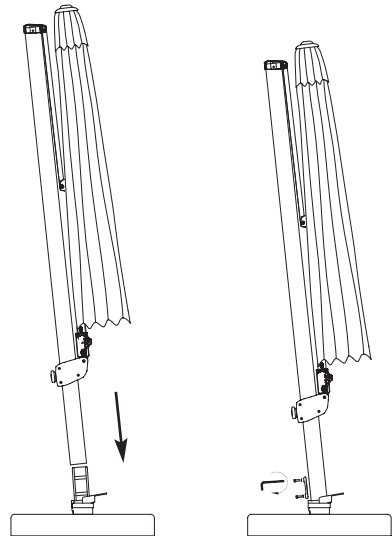
REMOVE ALL PLASTIC PACKAGING MATERIAL FROM ALL PARTS PRIOR TO OPENING UMBRELLA. CHECK UNDER CANOPY FOR PACKAGING AROUND RIBS.



STEP 3 Opening Canopy

In the closed position, turn adjustment knob counter clockwise  and slide the adjustment knob upward. Turn adjustment knob clockwise  to tighten and secure in place (Fig. 5).

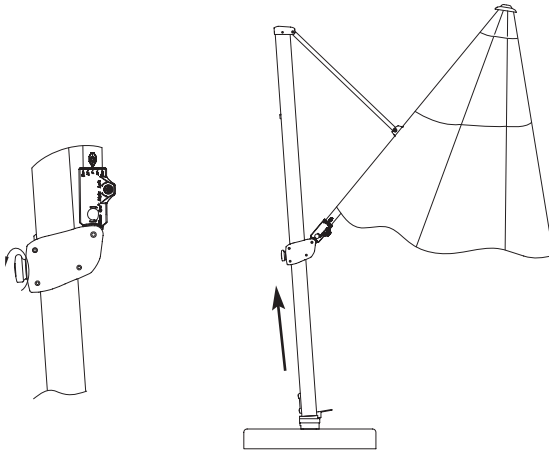

(Fig. 5)

Insert crank handle into “Open/Close” socket in crank mechanism (Fig. 6). Turn crank handle clockwise  until the canopy is fully open (Fig. 7). **CAUTION:** Stop turning the crank handle as soon as the umbrella canopy is completely open and the sleeve on the umbrella center pole has reached its maximum height.

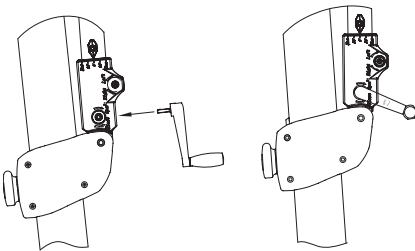

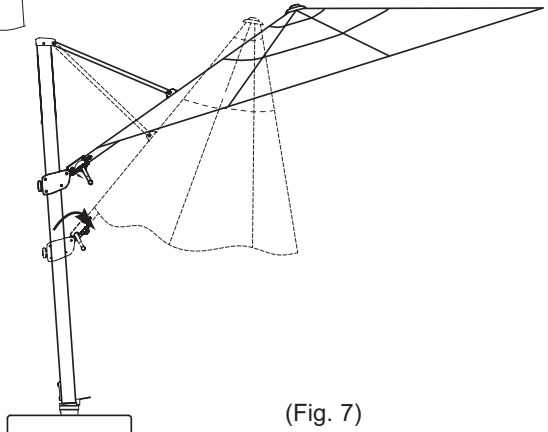

(Fig. 6)



(Fig. 7)

STEP 4 Tilting Canopy

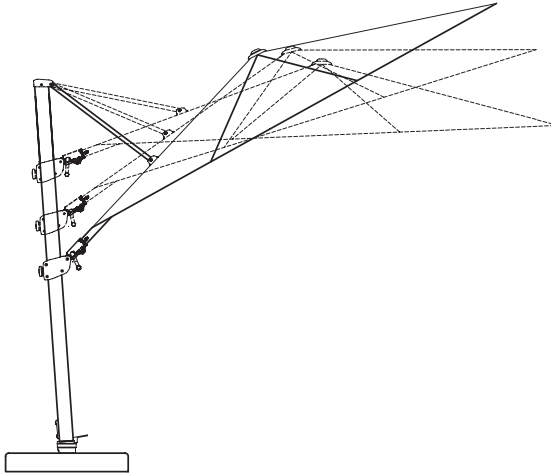

Tilting Front to Back

Turn adjustment knob counter clockwise  and slide car up and downward until desired height and angle is reached (Fig. 8). Tighten the adjustment knob clockwise  to lock its position. We do not recommend using tilt function during winds.



(Fig. 8)

Tilting Left to Right

Insert crank handle into “Right/Left” socket in crank mechanism (Fig. 9). To tilt canopy right, turn crank handle counter clockwise.  To tilt canopy left, turn crank handle clockwise. 

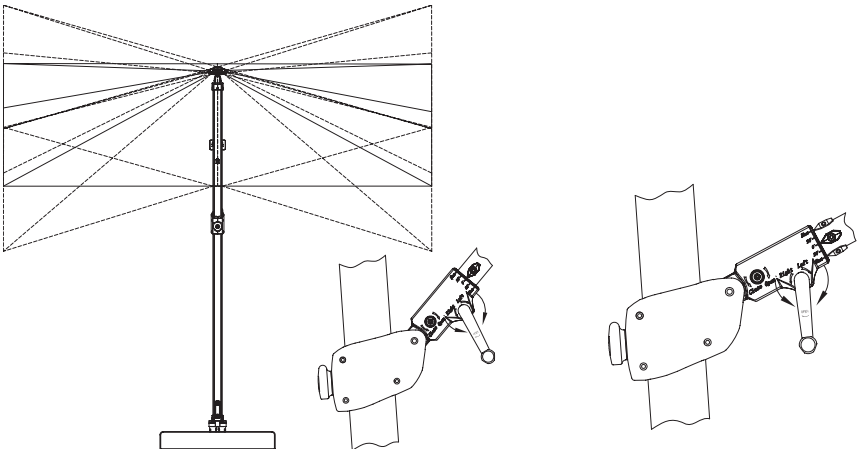



(Fig. 9)

STEP 4 360° Rotating Hub Swivel

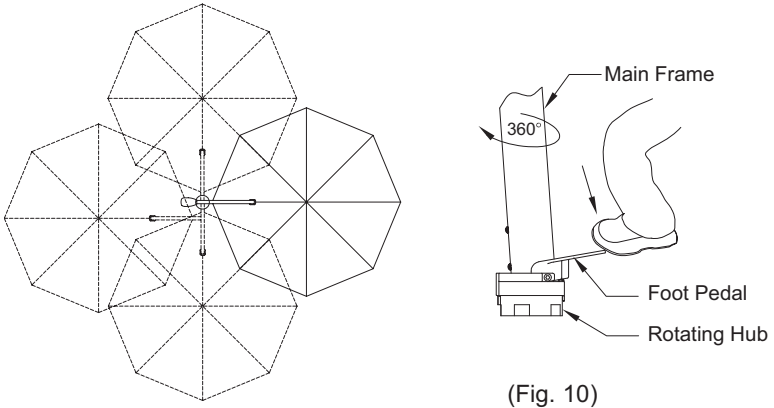
Place your foot on the foot pedal of the rotating hub and *step-on* the pedal to release rotating lock (Fig. 10). Place hands on the main frame and rotate the umbrella frame in either direction, in 90° increments. To lock position, step off the foot pedal to engage rotating lock.



STEP 5 Closing Canopy

Before closing, make sure canopy is at level position. Insert crank handle into “Open/Close” socket in crank mechanism. Turn crank handle counter clockwise  until the canopy is closed. Turn adjustment knob counter clockwise  and slide downward until umbrella is in closed position. Tie string around canopy to secure canopy. Cover umbrella with provided protective cover when not in use.

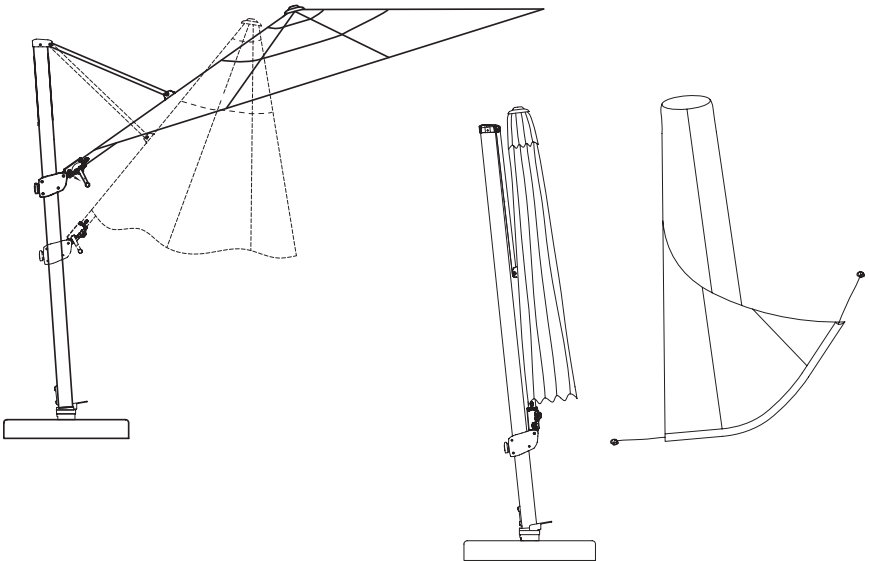

To ATTACH Umbrella Light:

Loosen the light adapter built into the lower hub by turning counter-clockwise

 (Fig. 11). After loosening, pull down light adapter post (Fig. 12) to attach the umbrella light (Fig. 13 and 14) (*sold separately*).

To REMOVE Umbrella Light and CLOSE adapter:

Remove umbrella light, and gently push up the light adapter post back into umbrella runner and tighten turning clockwise (Fig. 11). 

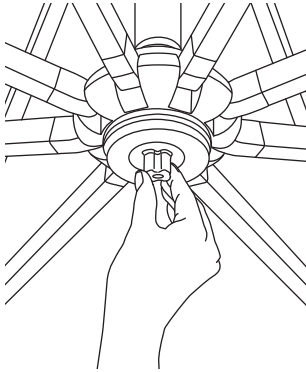

(Fig. 11)

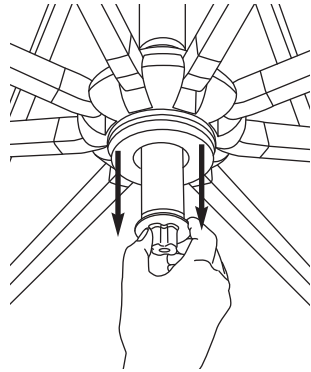

(Fig. 12)

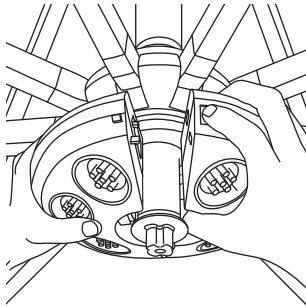

(Fig. 13)

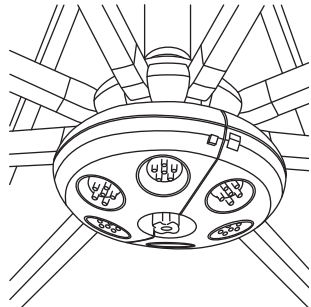

(Fig. 14)

WARRANTY:

SimplyShade warrants this product (in residential use) to be free from defects in original materials and workmanship for a period of 1 year from the date of purchase. If a defect in the original material or workmanship appears during the warranty period; SimplyShade will (at its option) repair or replace the product without charge. Limited warranty against fabric fading, depending on fabric.

Please contact your original authorized SimplyShade dealer with a description of the defect. The dealer will verify the defect and work closely with SimplyShade to obtain the necessary service. In many cases, simple problems can be solved with a replacement part that can be shipped directly to the dealer for professional installation/repair.

In the event that warranted factory service is required, SimplyShade will assume the responsibility of the return freight charges on warranted product for the 1 year only.

Returned product that (upon receipt and inspection) is deemed to be "not covered" under our warranty, will be shipped/billed at your expense.

This warranty gives you specific legal rights, and you may have other rights which vary from state to state.

NOTE: Failure caused by unreasonable or abusive use, or failure caused by neglect of reasonable and necessary care are not covered by this warranty.

Additionally, acts of nature (including but not limited to wind, hurricanes, tornadoes, and storms) are not covered by this warranty.

S A F E T Y P R E C A U T I O N S :

- Close the umbrella in windy conditions or when a storm approaches. Never allow the umbrella to flap in the wind; this could damage the canopy.
- Do not leave open umbrella unattended. If damage occurs, this is not covered by the warranty.
- When adjusting the umbrella, make sure that no person(s) or item(s) are close to the umbrella. This is important to prevent injury or material damage.

C A R E A N D M A I N T E N A N C E :

- When not in use, close and cover umbrella with a protective cover (sold separately).
- Allow a wet canopy to dry opened up.
- If necessary, clean the fabric with lukewarm water, mild detergent, and a sponge.
- Wipe sliding marks on the aluminum poles with a damp cloth.

Winter Storage:

- Store in a dry, protective place.

After the Winter:

- Areas subject to turning and sliding can be treated with a non-staining lubricant spray (silicone-based).
- Check the condition and function of the umbrella. Any defects must be repaired by a professional.

SimplyShade

www.simplyshade.com