

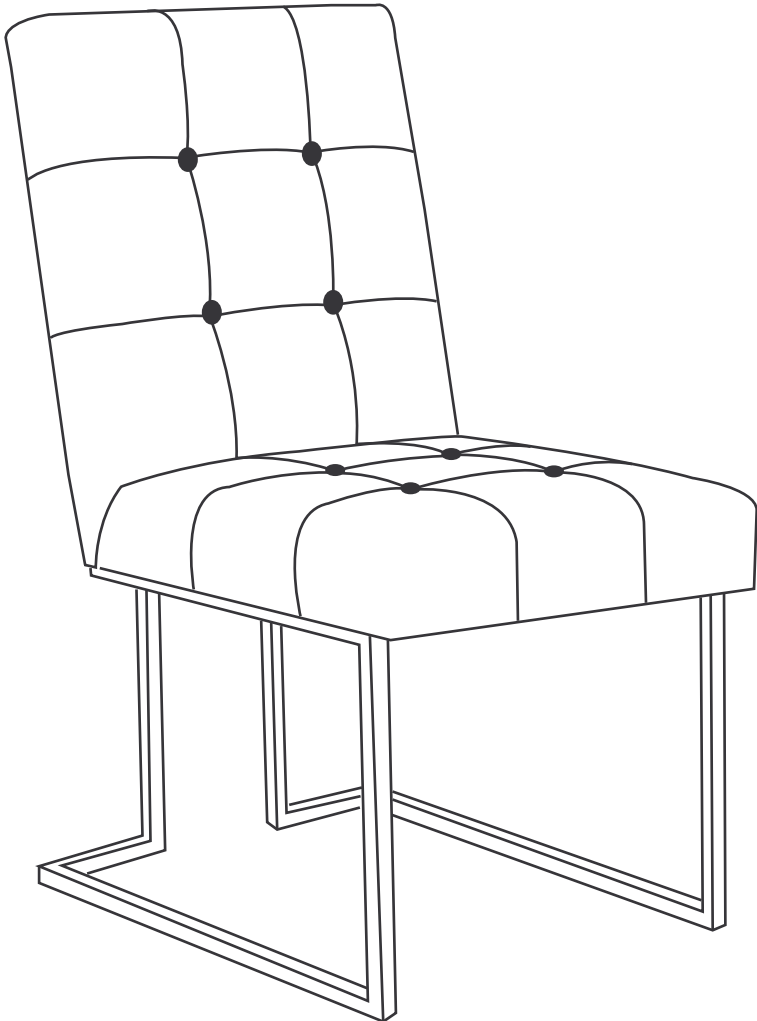







DINING CHAIR UC-16B



HARDWARE :

A×2	B×2	C×4	D×4	E×2	F×2	G×4
						
Φ8	Φ8	Φ6	M6	M8x55MM	M4x25MM	M6*25CM
Flat washer	Lock washer	Flat washer	Allen key	Longer Screw	Self-Tapping Screw	Shorter Screw

PARTS LIST

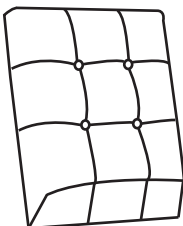
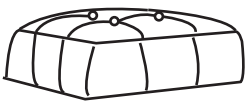
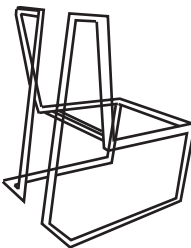
<p>H×1</p>  <p>Back</p>	<p>I×1</p>  <p>Seat</p>	<p>J×1</p>  <p>Legs</p>
---	---	---

1

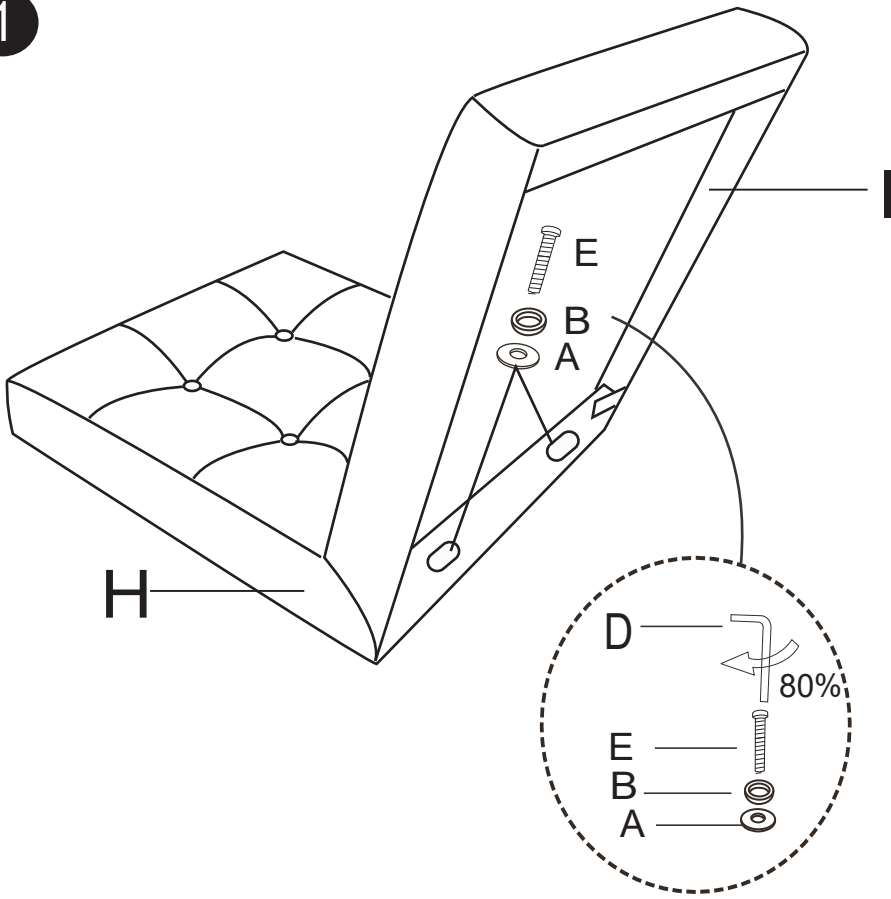

Put chair back on a clean flat surface.

Place seat pad against chair back as shown in diagram.

Secure center holes of the seat pad to chair back by using LONGER

SCREW (E) with Washer (#A,B).

DO NOT FULLY TIGHTEN.

First HAND tighten then tightened using key up-to 80% only at this stage.

2

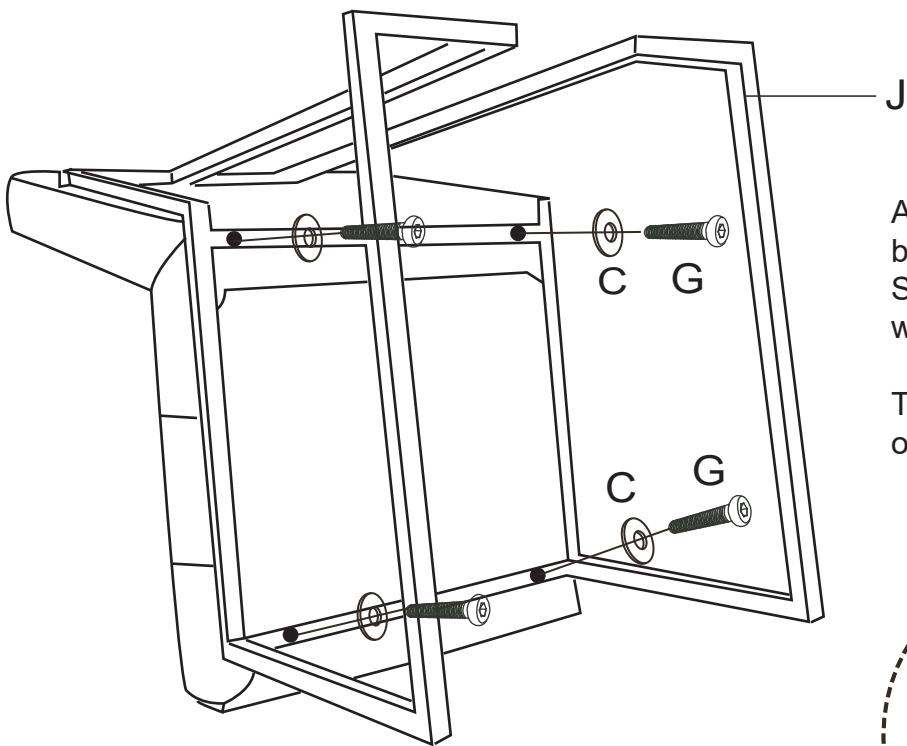

Assembly legs frame to the chair seat by using SHORTER SCREWS (G) with washers (#C).

Tightened up-to 100% using key only at this stage.

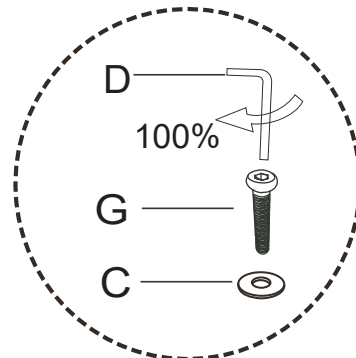

3

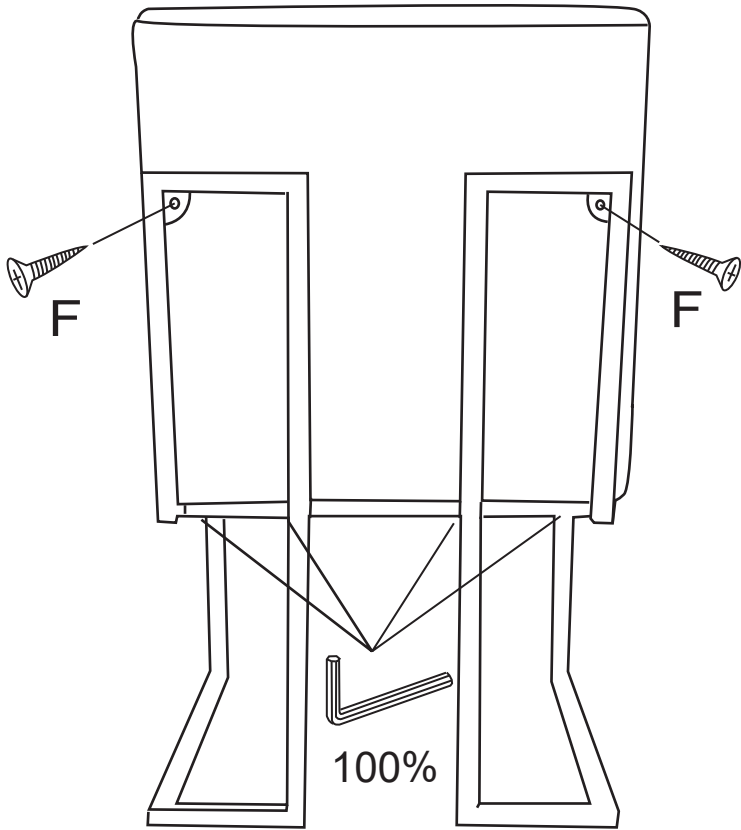

Using Self-Tapping Screw (F) lock 100% the frame and back
Then using Allen Key 100% lock all screws

4

