

8 x 8 Flat Top Pergola

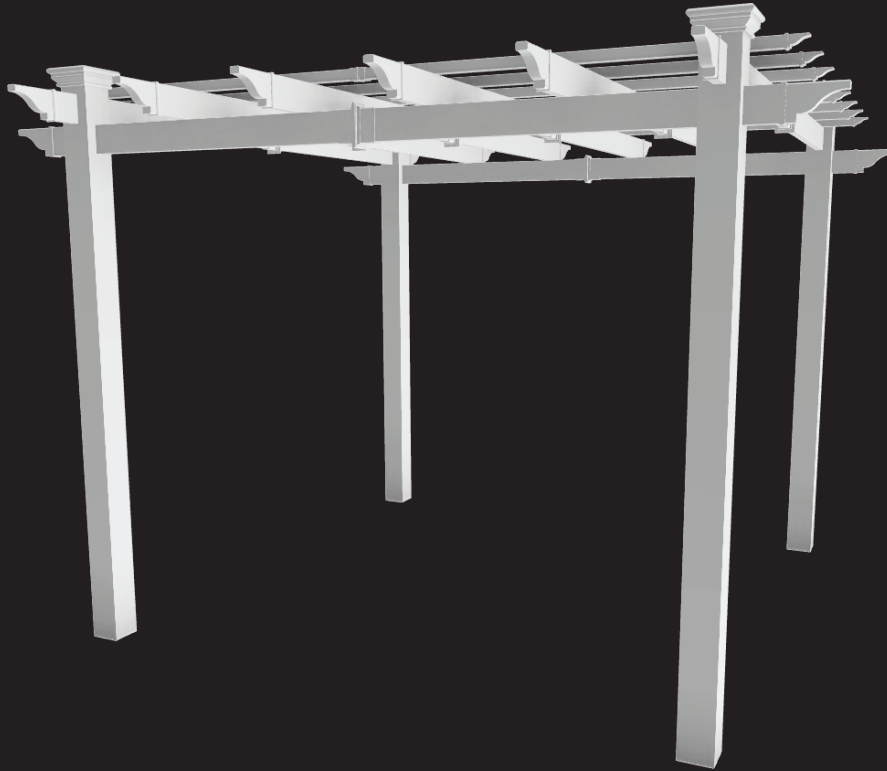

ASSEMBLY GUIDE



OPTIONAL ACCESSORY

- Bolt Down Bracket Kit



Models: **Mirage, Mandalay**

New England
Arbors
Leadership by Design

Table of Contents

	PAGE
8 x 8 Flat Top Pergola	
Introduction & Overview.....	3
Pergola Materials Overview.....	4
Pergola Materials Breakdown.....	5
Pergola Additional Materials List.....	6
Wood Post Layout & Installation for In-Ground Application.....	7
Wood Post Layout & Installation using Bolt Down Post Brackets for Concrete or Wood Surface.....	8
Vinyl Column Installation Over Wood Posts.....	9
Main Support Beam Assembly.....	10
Rafter Assembly.....	11
Main Support Beams & Rafter Placement.....	12
Fastening Main Support Beams, Rafters & Caps.....	13
Shade Slat Assembly & Installation.....	14

Introduction & Overview

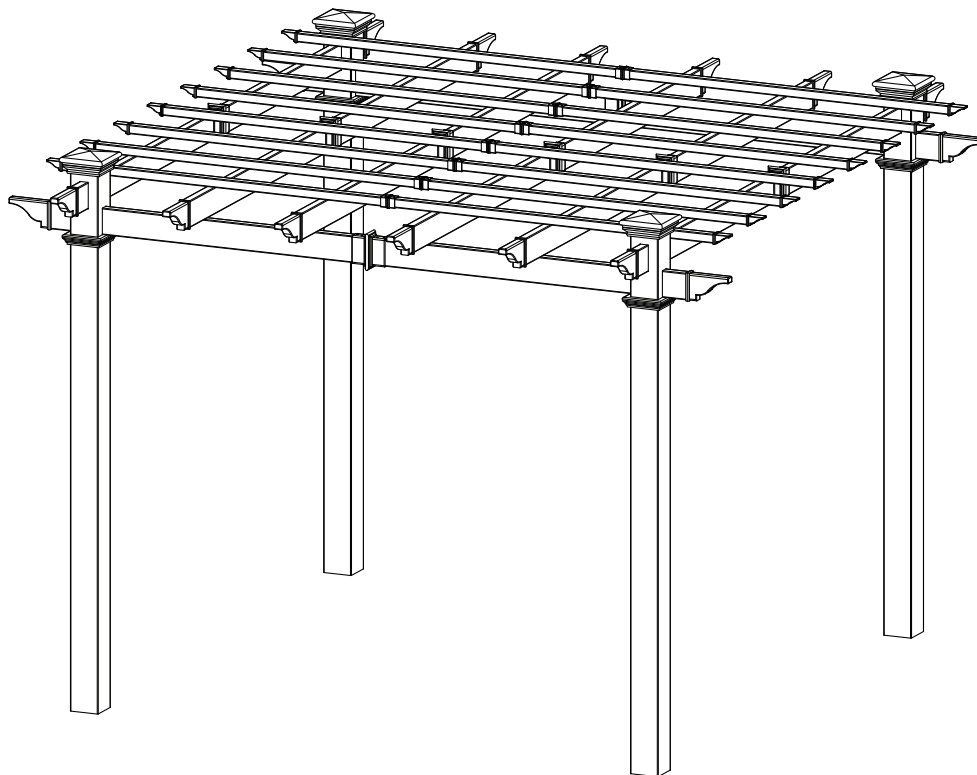

Getting Started

First off, allow us to say thank you for the investment you have made in one of our fine pergola kits. This kit is designed to be assembled and installed ideally by two people with basic carpentry knowledge and tools. Do not attempt alone, especially during the installation stage. Should you decide to moderately modify the dimensions of your pergola from the standard kit size, a circular saw with a sharp fine-tooth blade is all that is needed to cut, shorten or modify the vinyl components. The steel stiffeners for the main beams can be cut down using either a hacksaw or a motorized cutting device designed to cut steel. When assembling components place on a non-abrasive surface (ie: shipping box) to avoid scratching. We recommend a 15'x15' area for unobstructed assembling. You should not need to use excessive force when assembling any components.

Planning & Preparing

Because this project is made to stand independent of your home, you can either locate it near your house or let it stand alone in the garden. By keeping it unattached from your home you will not have to deal with moving existing gutters or matching eave heights. If you plan to build your pergola close to the house, please keep the outer extremities of the pergola a minimum of 4 inches back from your eaves.

What looks like the toughest part of this project is actually the easiest, the graceful, solid-looking columns. We've designed these columns to simply be slipped over treated 4x4 wood posts that are either embedded in concrete or directly mounted to a concrete or wood surface using our bolt down brackets. See pages 7, 8 and 9 for more details.

It is critical before you start that you consider the current slope of elevation where the pergola is planned - if there is any. Also utility or sprinkler line location is important to identify prior to excavating holes if necessary. You should also check to verify local building codes, ordinances, neighbourhood covenants, or height restrictions regarding this type of structure.

Restriction of Use

*This product **is not** designed to carry additional weight loads such as swings, people or other objects.*

Please take the time to read this instruction guide thoroughly prior to the construction of your pergola. If you have any questions, feel free to contact our technical dept by calling 1 800 282 9346 (Mon to Fri 8:00 A.M to 4:00 P.M. EST).

New England
— — — — —
Arbors
Leadership by Design
www.newenglandarbors.com

Mirage Pergola Materials Overview

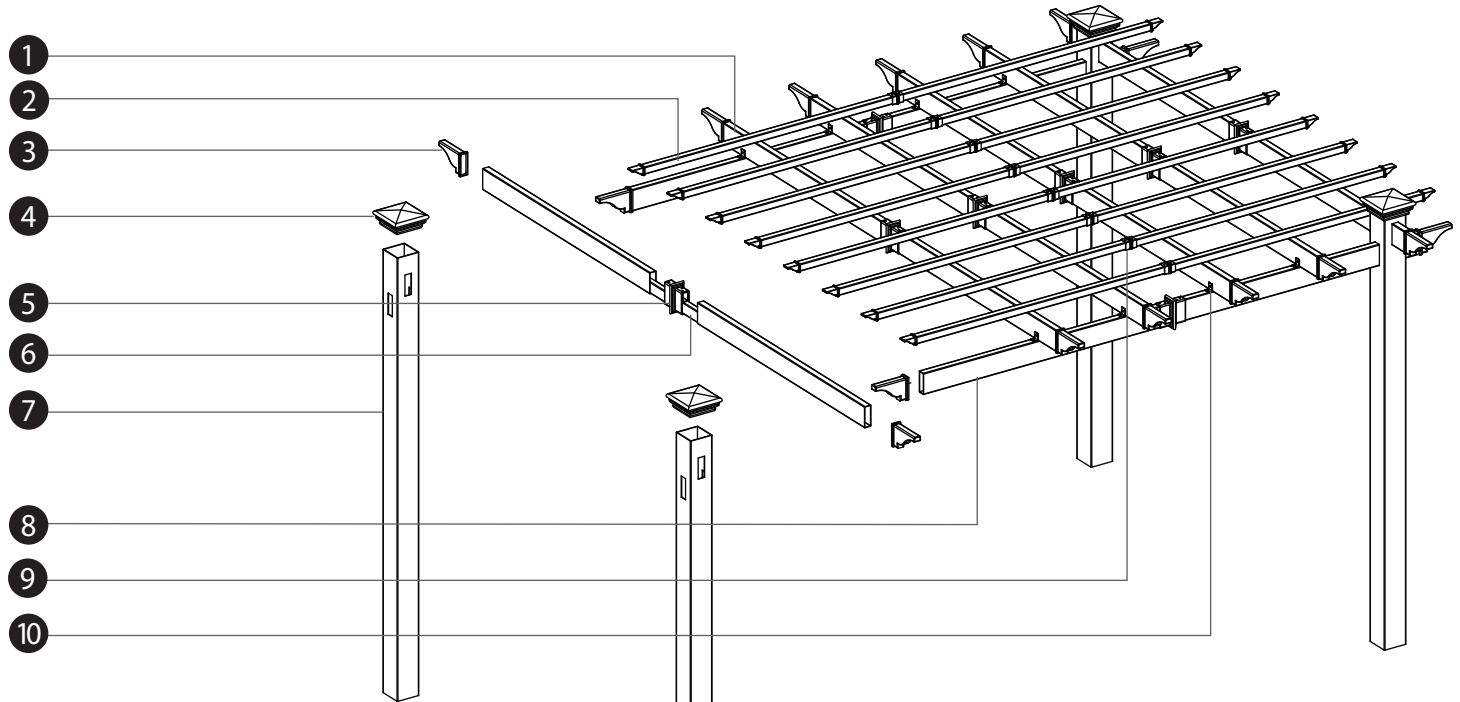

- 1. Rafters (12)
- 2. Shade Slats Including Decorative End Caps (16)
- 3. Rafter & Beam Decorative End Caps (16)
- 4. Post Caps (4)
- 5. Beam & Rafter Joiners (8)
- 6. Steel Stiffener Inserts for Main Support Beams & Rafters (8)
- 7. Posts (4)
- 8. Main Support Beams (4)
- 9. Shade Slat Joiners (8)
- 10. Rafter Brackets (8)

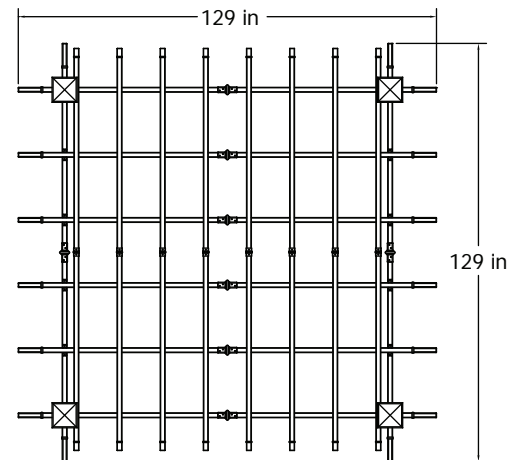

Top View

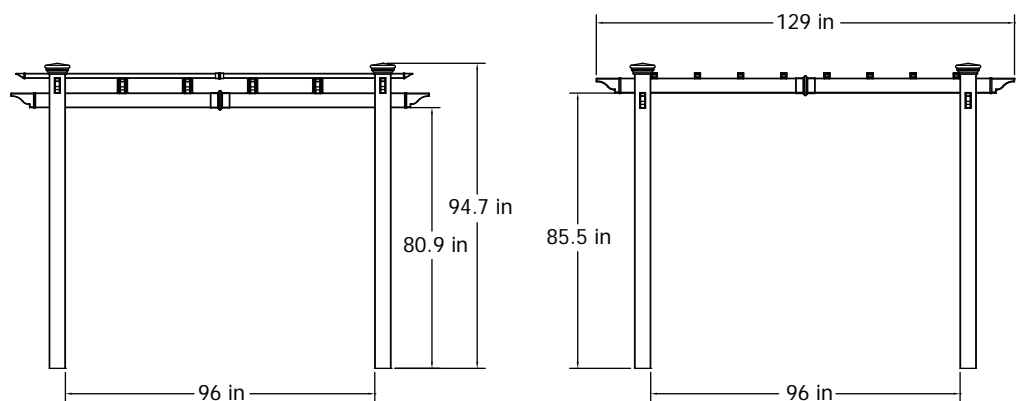

Front View

Side View

New England
Arbors

Leadership by Design

www.newenglandarbors.com

8 x 8 Flat Top Pergola

Mirage Pergola Materials Breakdown

(Mirage Pergola Accessories Not included)

Leadership by Design

www.newenglandarbors.com

Check Boxes (Total of 4) for These Contents

In the event of missing or defective parts please call our customer service dept. at **1 800 282 9346** (Mon. to Fri. 8:00 AM to 4:00 PM EST) .

- | | |
|---|--|
| <ul style="list-style-type: none"> 1. Rafters (12) 1.5" x 4.5" x 57.5" 2. Shade Slats (16) 1.5" x 1.5" x 57.2" 3. Rafter & Beam Decorative End Caps (16) 4. Post Caps (4) 5. Beam & Rafter Joiners (8) 6. Shade Slat Decorative End Caps (16) | <ul style="list-style-type: none"> 7. Steel Stiffener Inserts for Main Support Beams (2) 8. Steel Stiffener Inserts for Rafters (6) 9. Main Support Beams (4) 1.5" x 4.5" x 57.5"
(Pre-drilled holes on top edge) 10. Shade Slat Joiners (8) 11. Rafter Brackets (8) 12. Posts (4) 5" x 5" x 94" |
|---|--|

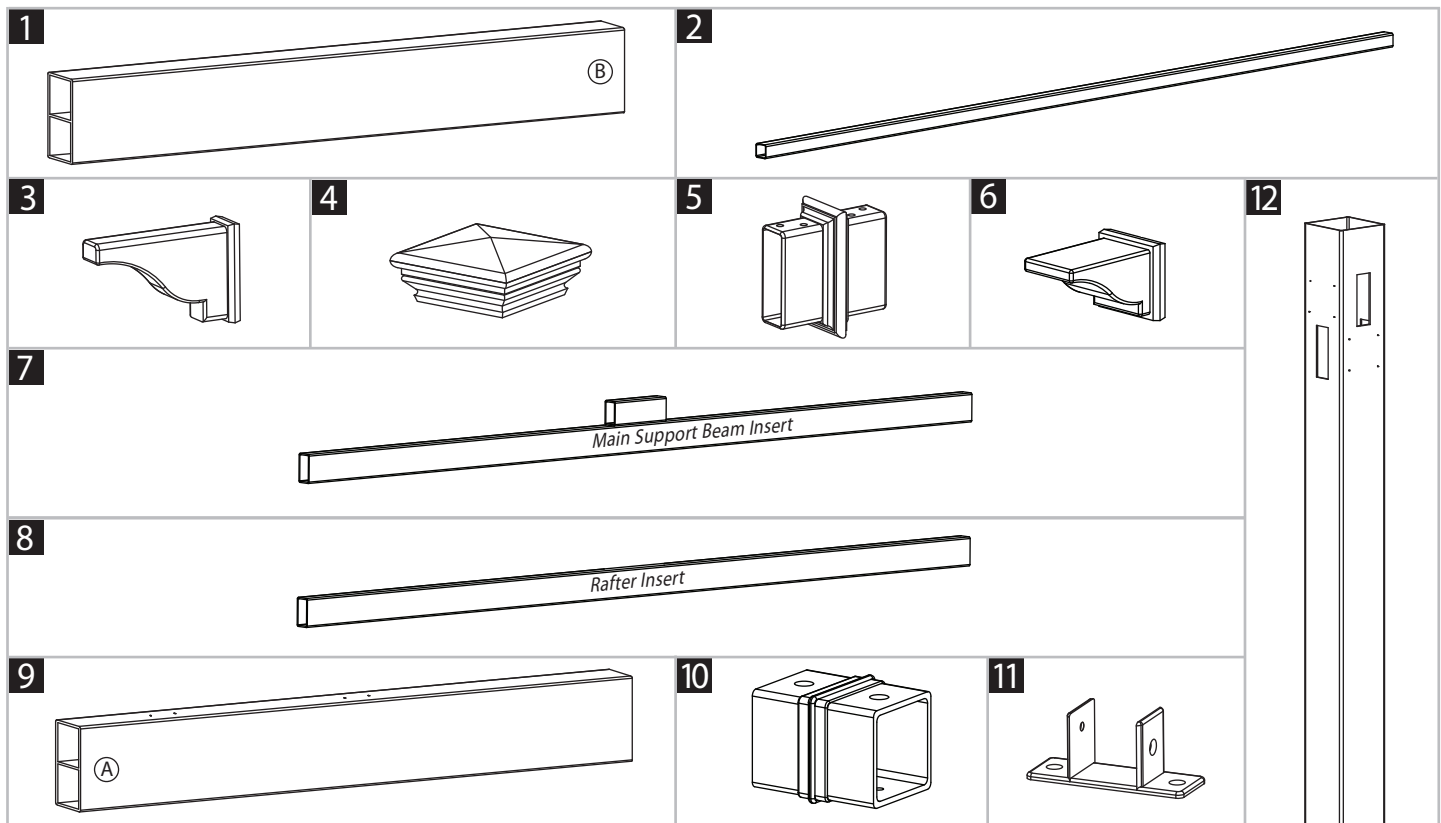

Not to Scale

Mandalay Pergola Materials Breakdown

The above 4 boxes & an additional box with 4 base molds and 4 decorative post trims.

- 13. Short Base Molds (4)
- 14. Decorative Post Trims (4)

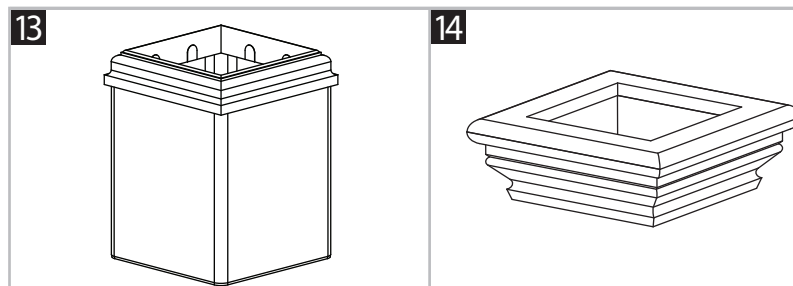

Pergola Additional Materials List

Hardware *(in plastic bag)*

NOTE: WE HAVE INCLUDED 10% EXTRA SCREWS BEYOND WHAT IS IDENTIFIED BELOW.

All Screws Included with this Kit are Self-Auguring.

- A. Vinyl Weld Glue (3)
- B. 5/8" Self-Auguring Stainless Steel Screws (32) *(for Rafter Brackets)*
- C. 1 1/2" Self-Auguring Stainless Steel Screws (48) *(for Main Beam Joiners with Steel Stiffener Inserts)*
- D. 2 1/2" Self-Auguring Stainless Steel Screws (48) *(for Shade Slats)*
- E. 2 1/2" Self-Auguring Stainless Steel Screws (16) *(to secure vinyl posts to internal wood posts)*
- F. 4" Self-Auguring Stainless Steel Screws (64) *(for Posts and Rafter Joiners)*
- G. 1/8" x 2" Drill Bit (1) *(to pre-drill holes on bottom of Main Beam Joiners for screws to penetrate Steel Stiffener Inserts as necessary)*

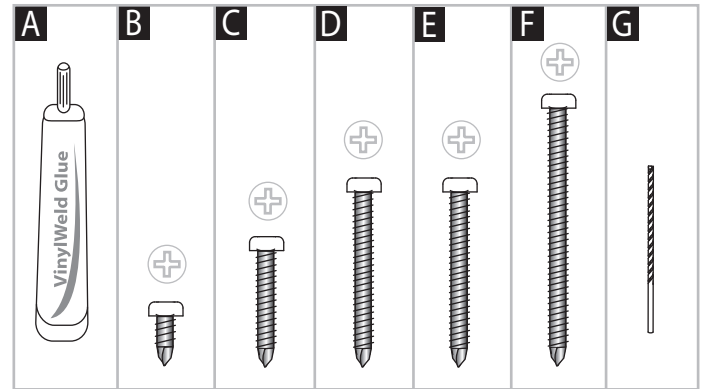

Extra Materials You will Need

(Purchase separately from www.newenglandarbors.com or retailer of our products)

If Mounting Pergola on Concrete or Wood Deck

- J. 4x4x4 Pressure-Treated Wood Posts (4) *(purchase at local building center)*
- K. 4x4 Bolt Down Bracket Kit *(purchase from www.newenglandarbors.com or a retailer of our products)*

Refer to bolt down bracket instructions for hardware requirements, as they pertain to your application:

If mounting pergola onto an existing concrete surface:

- 1/2" x 3 1/2" x 12" Wood Shims (32)
- 1/4" x 2 3/4" Cement Screws - Countersunk Head (12)
- 3/16" Concrete drill bit. Minimum 3" long (1)

If mounting pergola onto a wooden/composite deck with AN ACCESSIBLE UNDERSIDE:

- 1/2" x 3 1/2" x 12" Wood Shims (32)
- 1/4" x ?" Bolts and Nuts - Countersunk Head (12) *(Length depends on blocking material)*
- 1/4" Washers (12)
- 1/4" Wood drill bit. Minimum 3" long (1)

If Mounting Pergola in Ground

- L. 4x4x8 Pressure-Treated Wood Posts (4) *(purchase at local building center)*
- M. Concrete Ready Mix (4) *(purchase at local building center)*

Tools You Will Need

- Level
- Hammer
- Tape Measure
- String Line
- Wood Stakes (4) *(temporary support for string line)*
- Step Ladders (2)
- Cordless Drill

Tools You May Need

- Circular Saw with Fine Tooth Blade
- Framing Square
- Framing Level
- Hacksaw *(or a motorized cutting device designed to cut steel)*

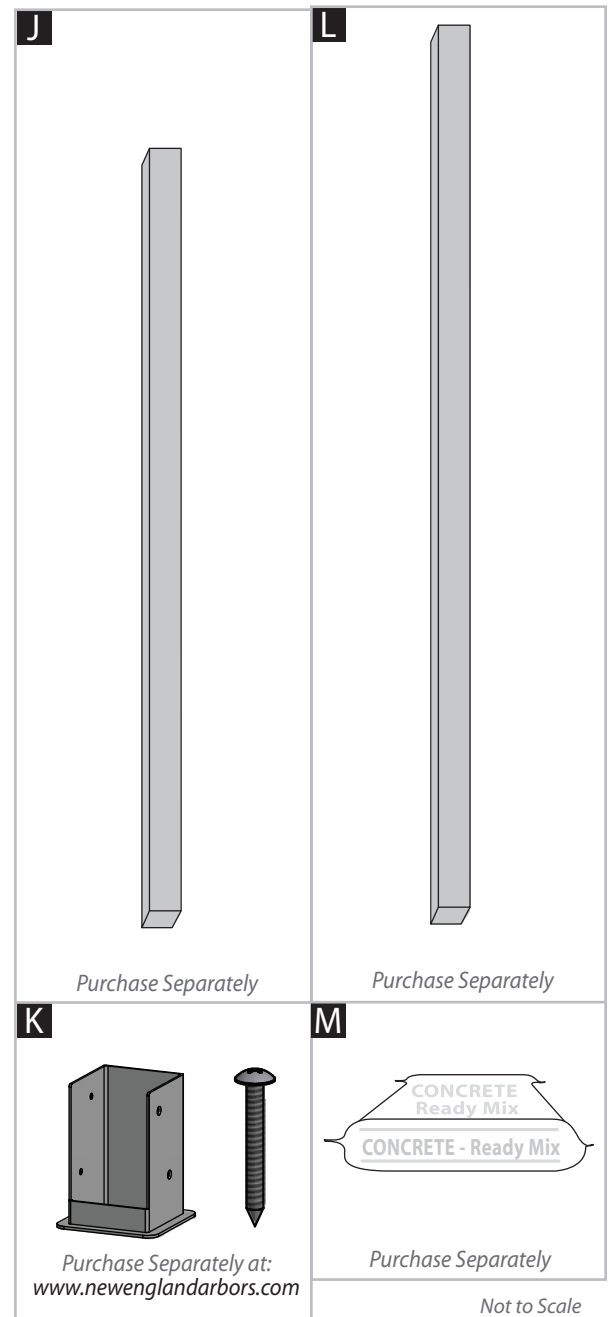

Wood Post Layout & Installation for In-Ground Application

This pergola can also be installed on a pre-existing wood or concrete surface using our bolt down bracket system with a 4x4 wood post (sold separately). See page eight for more details.

Post location and placement is the most critical step in the overall installation process. Please double check for the possibility of any underground utilities such as sprinkler, gas or telephone lines.

STEP ONE

Measure and mark out the location of the pergola posts using string line and temporary wood stakes. Diagonal distances must be the same to ensure a square installation. Adjust string lines accordingly. The inside corner of the string lines will be the post location.

Please Note:

Should you decide to moderately modify the dimensions of your pergola from the standard kit size, a circular saw with a sharp fine-tooth blade is all that you need to cut, shorten or modify the vinyl components. The steel stiffeners for the main beam can be cut down using either a hacksaw or a motorized cutting device designed to cut steel.

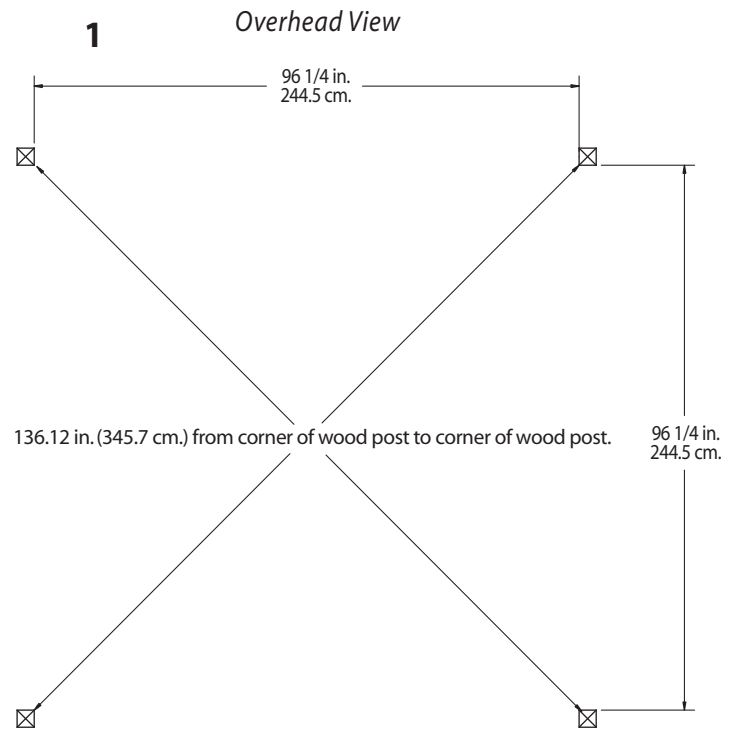

STEP TWO

Install Wood Supporting Posts Directly into the Ground

1

After you have determined where the posts will be located, excavate 10" diameter x 36" deep post holes.

2

After holes are dug and cleaned, place the 4x4 wood post into a hole ensuring it's level and square to string lines. The final post height should be about 60" out of the ground.

3

Fill the vacant hole with pre-mixed concrete all the way to within 3" of the top of the hole. Once the concrete has set, back-fill the 3" space with soil.

4

Repeat for all four posts.

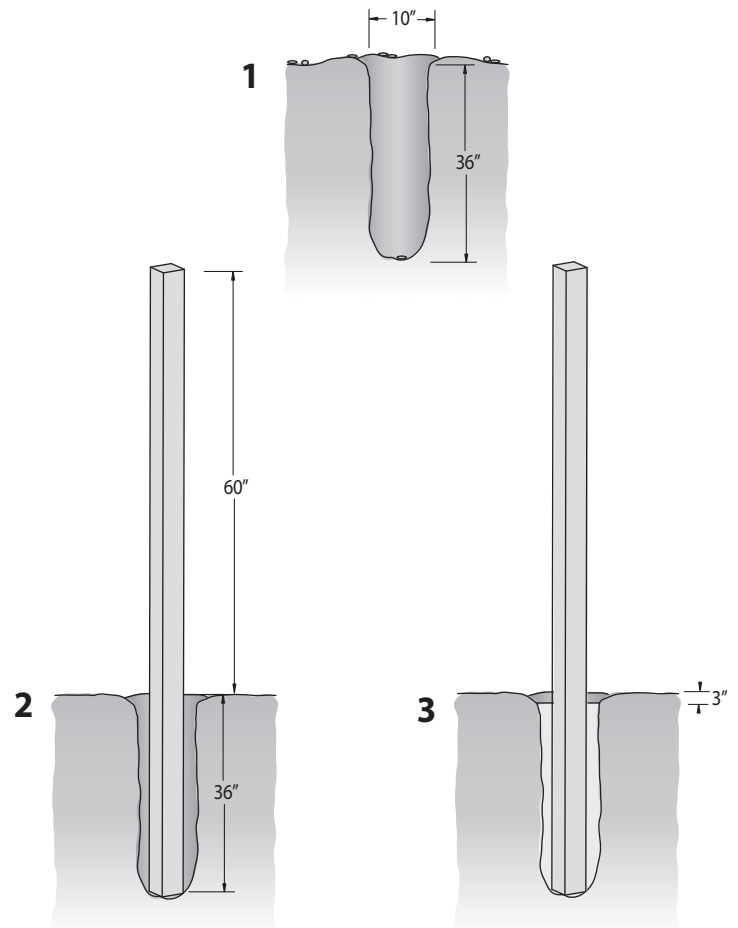

OPTIONAL STEP

Wood Post Layout & Installation Using Bolt Down Brackets for Concrete or Wood Surface

1

Measure and mark out the location of the pergola posts using string or chalk line. Diagonal distances must be the same to ensure a square installation. Adjust string lines accordingly. The inside corner of the string lines will be the post location.

2

Mark out the location of bolt down brackets as illustrated.

3

Using a 3/16" masonry drill bit, drill 3" deep holes to allow installation of 2 3/4" concrete screws (Not included)

4

Proceed to install three 2 3/4" concrete screws into the bottom base of the bolt down bracket (not included)

Please Note:

Concrete patios generally have sloped surface for water run-off. If this is the case, when you secure the bolt down bracket to the concrete, the bracket may be at an angle. This can be corrected for level using galvanized steel washers (not provided), acting as shims underneath the base to level - **VERY IMPORTANT OR PERGOLA BEAMS AND RAFTERS WILL NOT BE LEVEL.**

5

With the four post brackets installed plumb, proceed to set the 4x4 x4' wood post in place. Secure using the same concrete screws included in the kit. Repeat for all 4 posts.

6

Posts should be approximately 48" in height.

7

In order to create a snug fit between the wood posts and the inner cavity of the vinyl posts, it will be necessary to 'build out' the 4x4 posts near the bottom and the top using 1/2" x 3 1/2" x 12" shims on all four sides (not supplied).

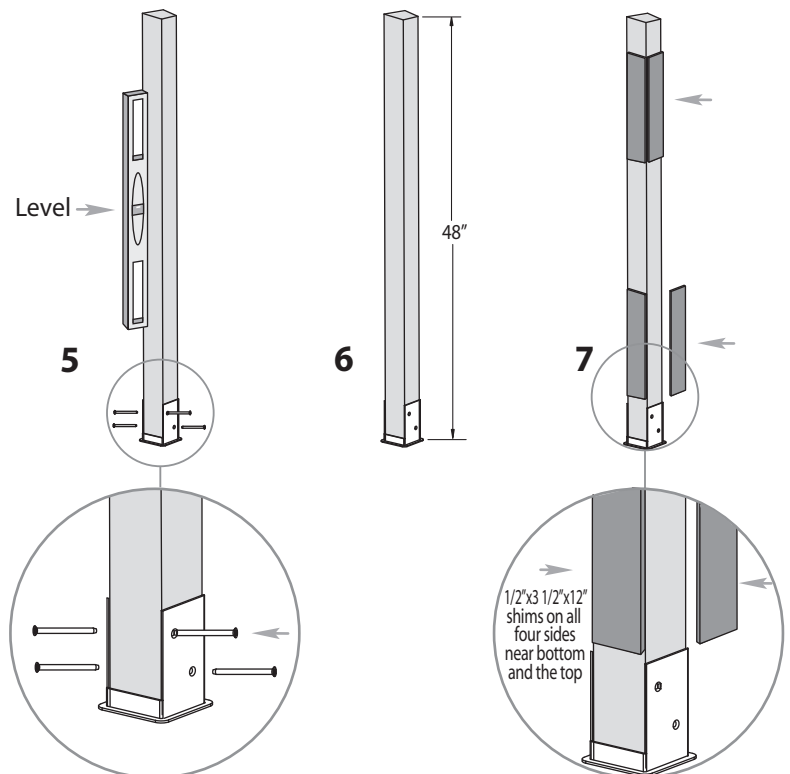
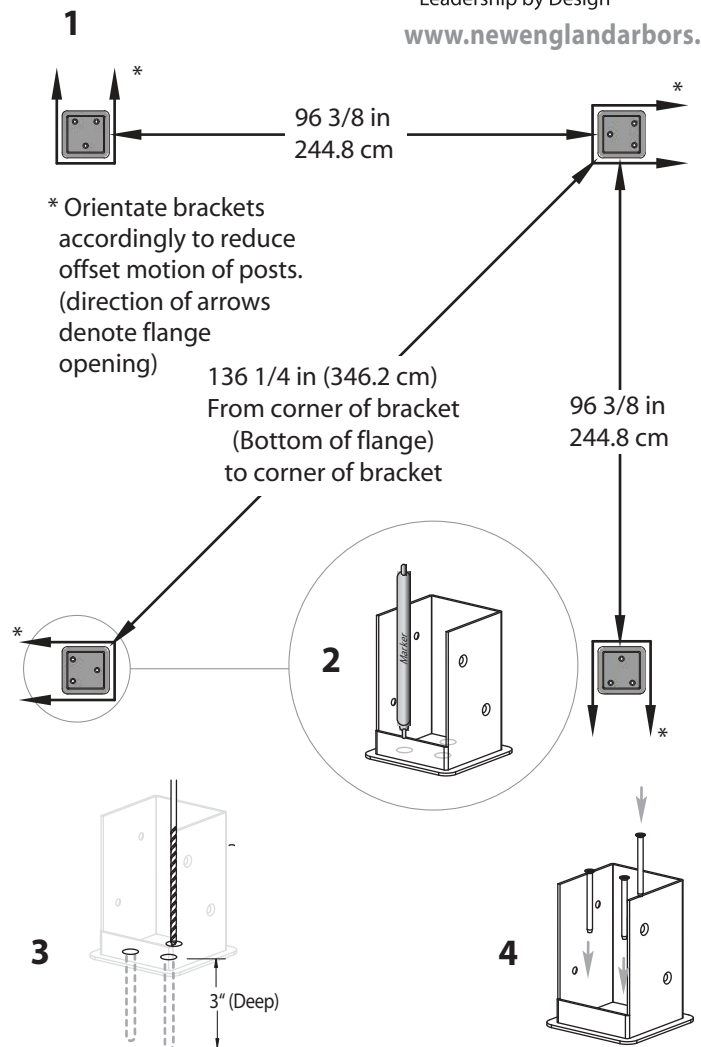

STEP THREE

Vinyl Column Installation Over In Ground Wood Posts

1

Using a step ladder, guide the vinyl column over the top of the wood post down into position. **Ensure that holes at top of column are orientated correctly for future beam and rafter placement as per illustration.**

Please Note:

If you installed your wood posts directly into the ground, please proceed to position the vinyl column tight to the inside corner of the wood posts as illustrated below. **NO SHIMS REQUIRED.**

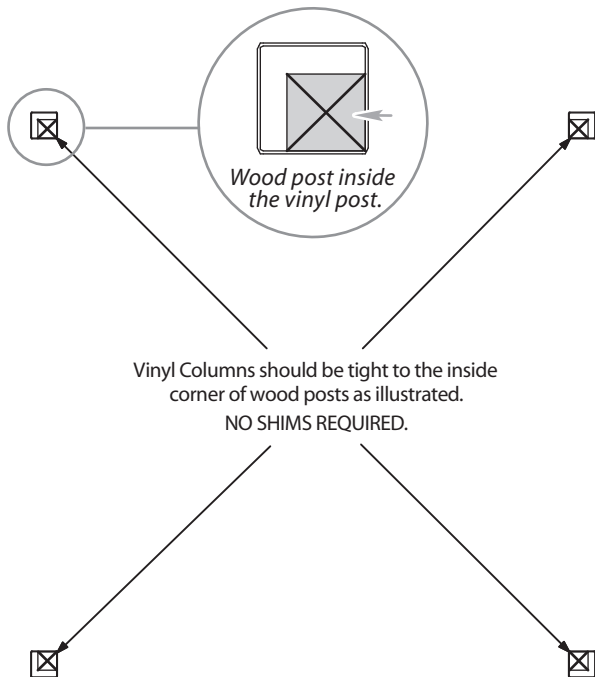

If you purchased the Mandalay, follow steps 2 and 3.
If you purchased the Mirage, skip to step 4.

2

Slide Base Mold down the post to the ground.

3

Slide post trim on to the post. Trim should measure 12" below lowest hole in post.

4

Finally, adjust post heights accordingly to ensure future level installation of beams and rafters as necessary. If slope is severe causing a height difference between the posts, you may need to trim down the bottom of two or more of your vinyl columns as necessary.

5

Secure the vinyl columns to the wood posts using 2 - 2 1/2" screws at 8" up from the bottom (on 2 sides, and 2 more approximately 36" high (on 2 sides).

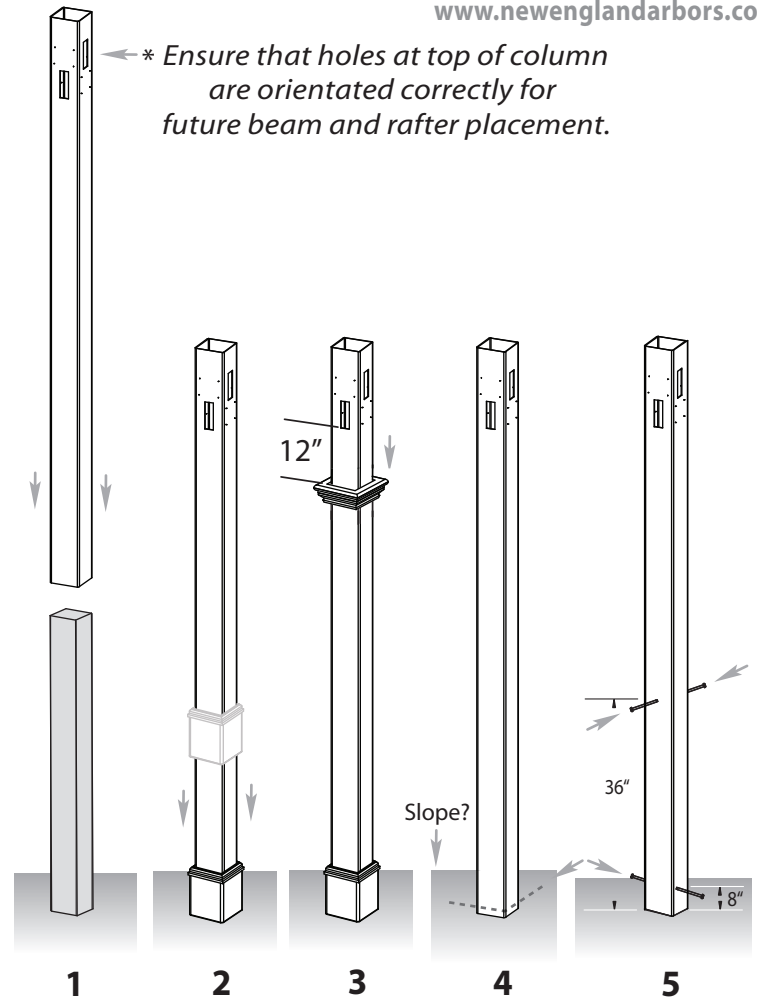

Vinyl Column Installation Over Wood Posts with Bolt Down Brackets

6

The process for posts installation over the bolt down bracket is identical as shown below.

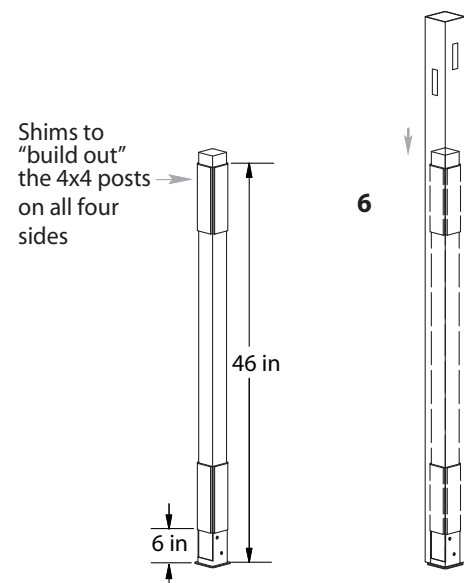

At this stage, the columns should be properly installed as per the following illustration, with the columns 96 in. (243.8 cm.) apart. Also, notice that the holes at the top of each post should be facing the same direction.

Note: If you have base molding on your posts, measure above moldings as the measurement is to be from post to post.

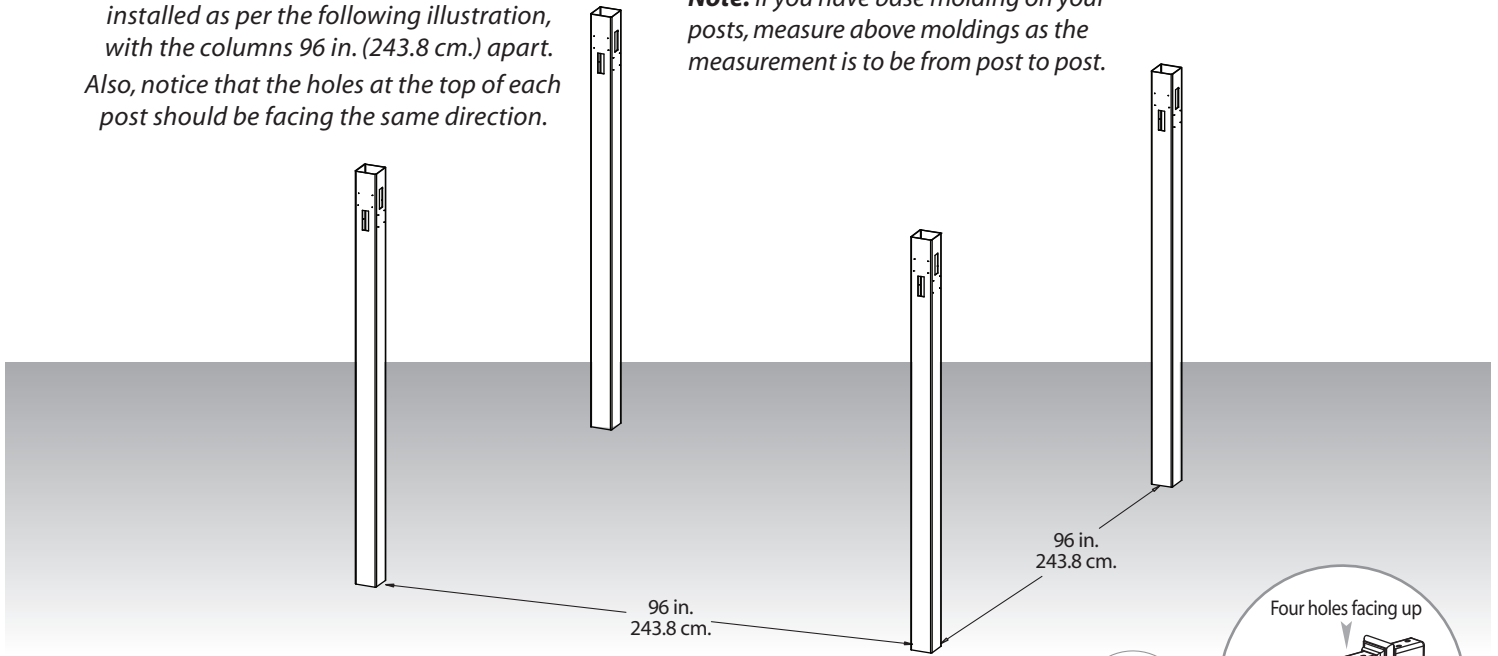

STEP FOUR

Main Support Beam Assembly

1

Insert the end of the main support beam marked 'A' into a joiner. **Pre-drilled holes should be facing up.** Install the joiners so that the side with the four holes are facing up. Push firmly so the extrusion bottoms out inside the joiner.

2

Insert one steel stiffener (with steel block facing up), into the lower pocket of the main support beam. Push until steel block hits the internal ribbing

3

Slide the other end of vinyl beam marked 'A' (with pre-drilled holes facing up) over the steel insert and into the joiner to create one full main support beam.

4

Using 1 1/2" screws, fasten the joiner to main support beams and steel insert. The bottom and top holes will need to be pre-drilled (use drill bit provided).

5

Repeat for other main support beam.

6

Using 5/8" screws, install the rafter brackets to the main support beams. Follow the pre-drilled holes to identify locations.

1

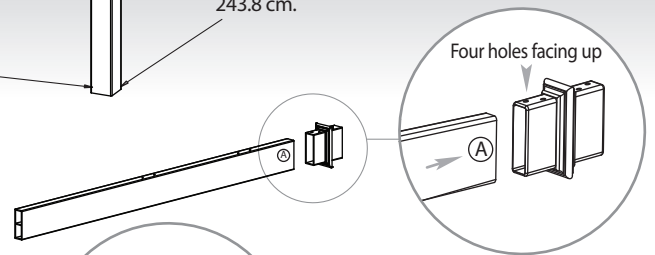

Steel block should face up

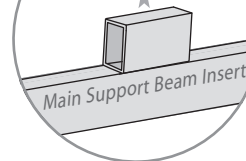

2

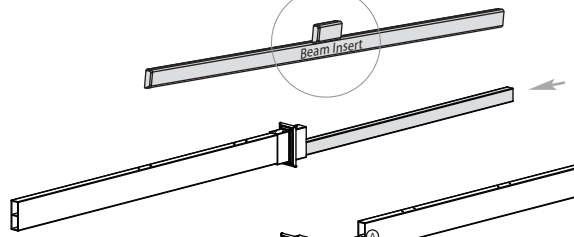

3

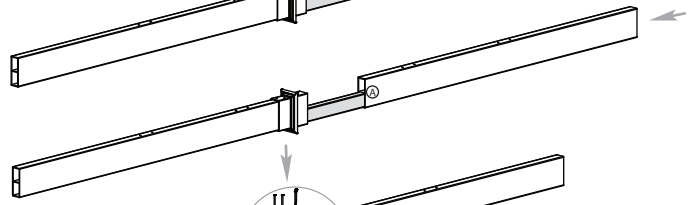

4

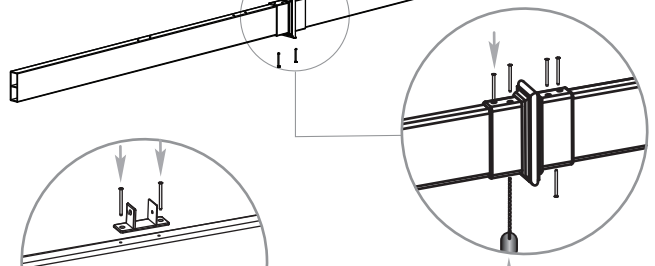

Pre-drill holes on bottom and top to accommodate for internal steel stiffener.

6

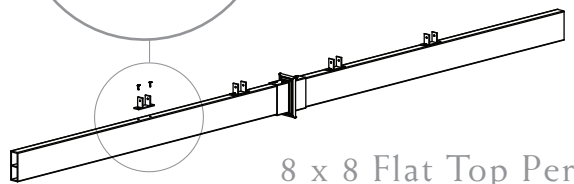

8 x 8 Flat Top Pergola

STEP FIVE

Rafter Assembly

1

Insert the end of the rafter marked 'B' into a joiner. Install the joiners so that the side with the four holes are facing up. Push firmly so the extrusion bottoms out inside the joiner.

2

Insert one steel stiffener into the lower pocket of the rafter. Push until steel block hits the internal ribbing.

3

Slide the other end of rafter marked 'B' over the steel insert and into the joiner to create one full beam.

4

Using 1 1/2" screws, fasten the joiner to vinyl rafters and steel insert. The bottom and top holes will need to be pre-drilled (use drill bit provided).

5

Repeat for other beams.

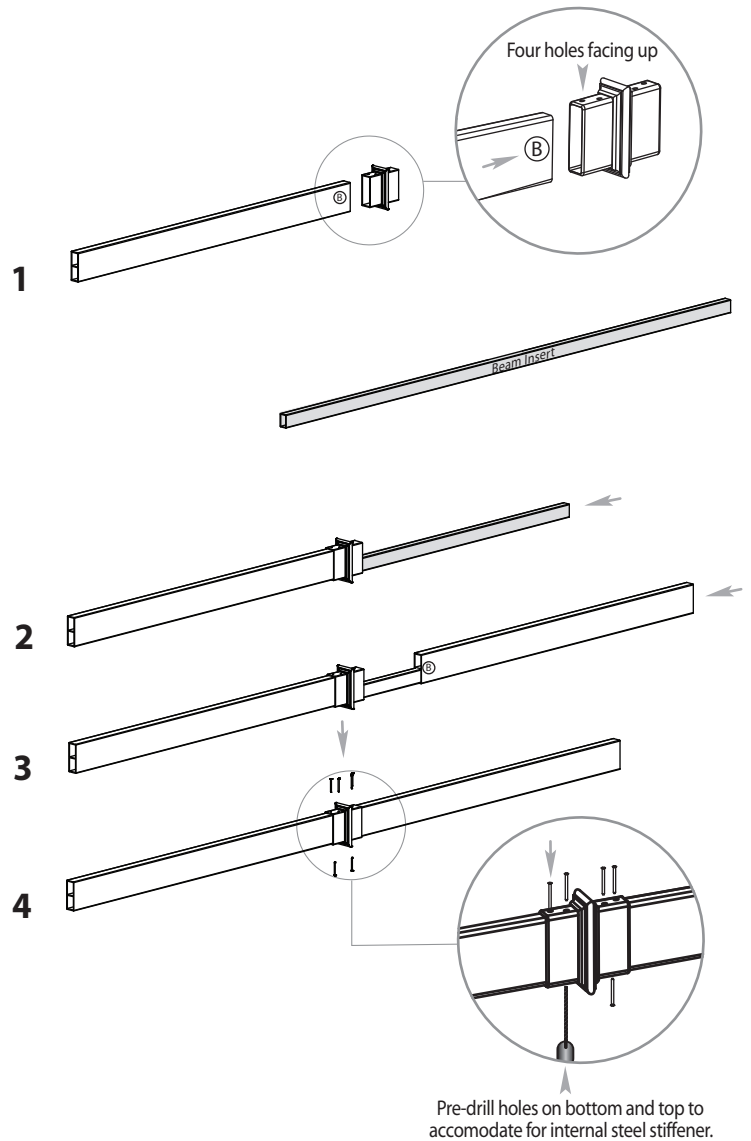

STEP SIX

Main Support Beams & Rafter Placement

Using a helper and two ladders proceed to complete the following steps:

1

Slide the main support beam with rafter brackets pre-installed through both holes of the vinyl column (overshooting), and then back through both holes of the opposite column. Repeat for opposite beam.

Please Note:

The top of the vinyl columns may need to be tensioned in opposite directions to each other to allow the beams and rafters to be installed on a slight angle. The vinyl columns naturally allow some measure of flex.

2

Slide the two outer rafters through both holes of the vinyl column (overshooting) and then back through both holes of the opposite column.

3

Using 4" screws, lock the main support beams and rafters into position inside the posts by driving in 8 screws from the outside and 8 screws from the inside of each column.

4

Place the remaining rafters in the front and rear rafter brackets.

5

Complete a final adjustment of all rafters. All overhang should appear equal to the eye.

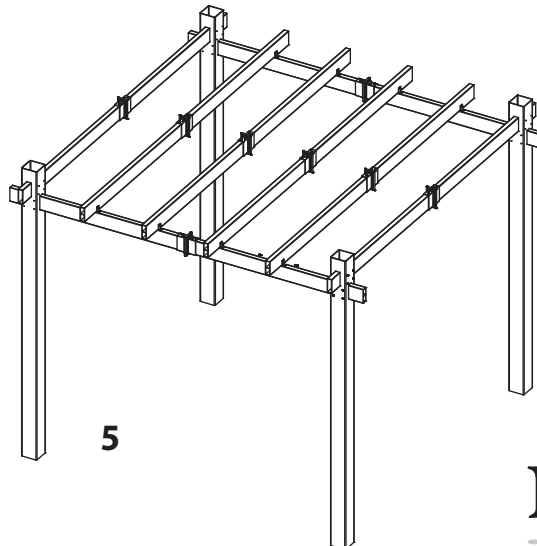
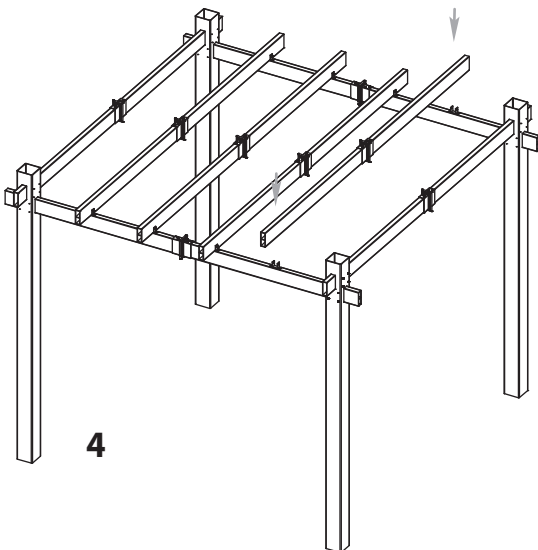
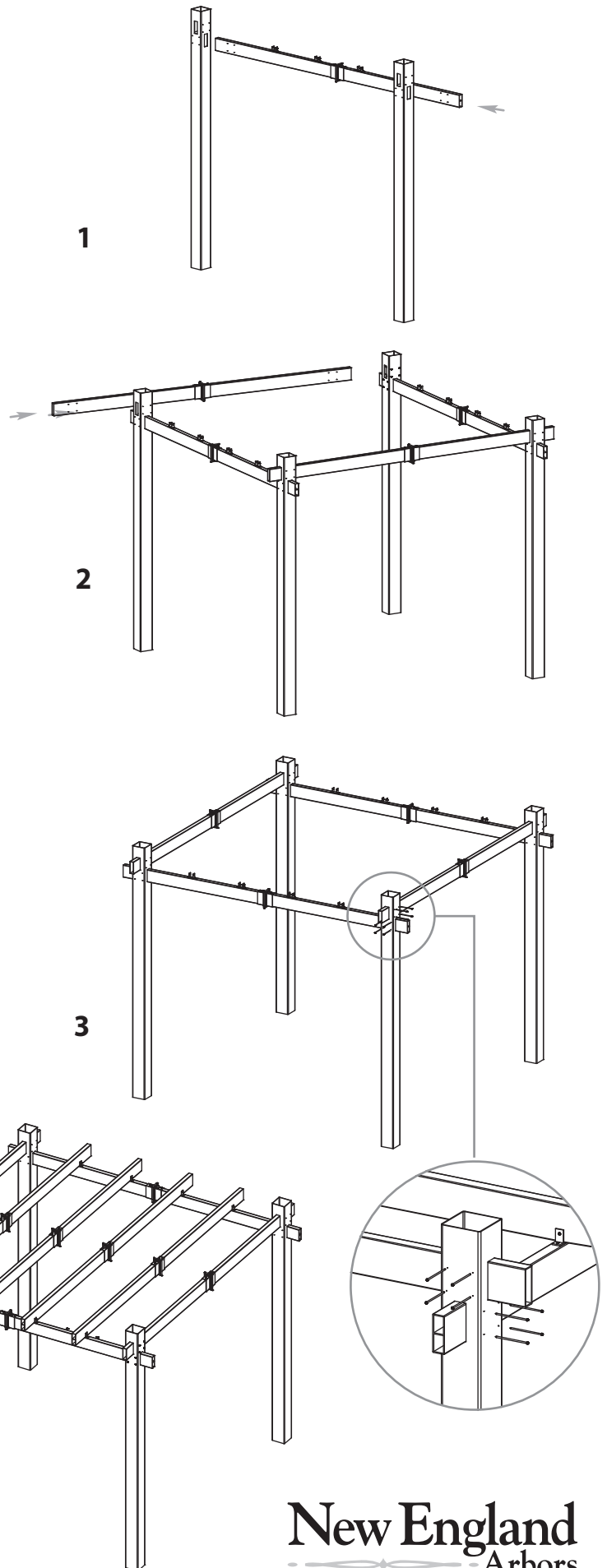

New England
Arbors

Leadership by Design

www.newenglandarbors.com

STEP SEVEN

Fastening Rafters & Caps

1

Using 5/8" self-auguring stainless steel screws attach the pergola rafters to the rafter brackets.

2

Install the post caps using vinyl weld.

3

Install decorative pergola end caps using vinyl weld.

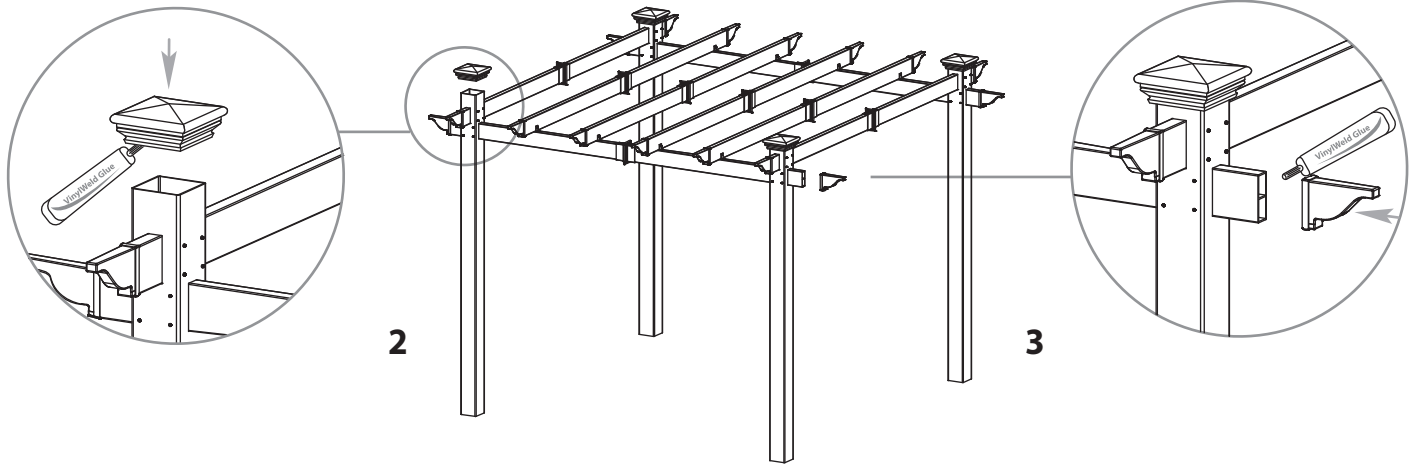
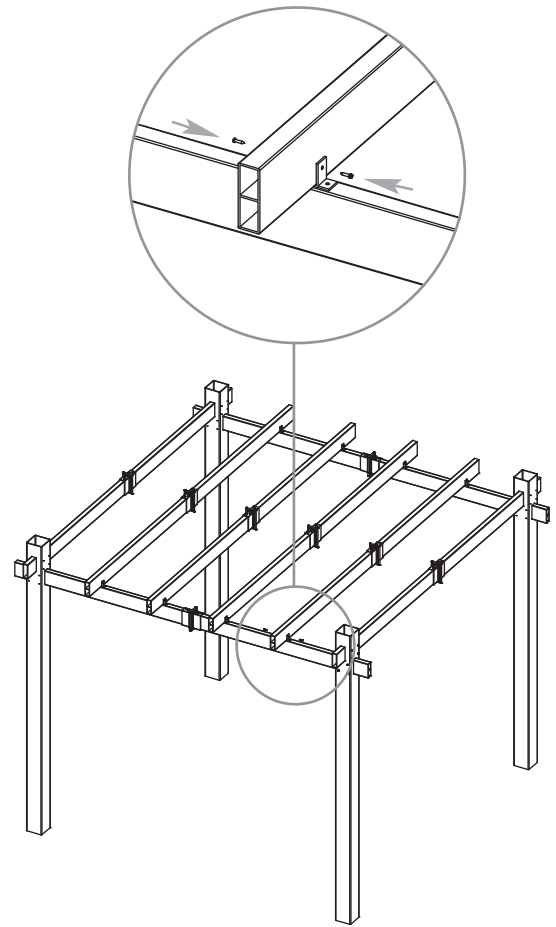

STEP EIGHT

Shade Slat Assembly

1

Assemble shade slats by first gluing the decorative end cap as shown, and then inserting the two slats into one joiner. Push firmly until extrusion bottoms out inside joiner. **No screws are necessary in the joiners.**

Shade Slats Installation

Shade slats are designed to extend approximately 8 1/4" past the last rafter. Measurement includes the pre-installed pergola end caps. Your goal is to ensure that all the shade slats overhang equally to the eye.

2

Install first shade slat adjacent to the top of the vinyl columns.

3

Install the rest of the shade slats at 11 1/2" spacing.

4

Install one 2 1/2" screw at each intersection of rafter and shade slat.

Suggestions for Additional Shade as Necessary

- White resin lattice in variety of shapes and sizes are available at your local lumberyard. Cut to size and fasten directly to the top of shade slats using stainless steel screws.
- In areas of extreme snow or wind load, do not use tight diamond privacy lattice.

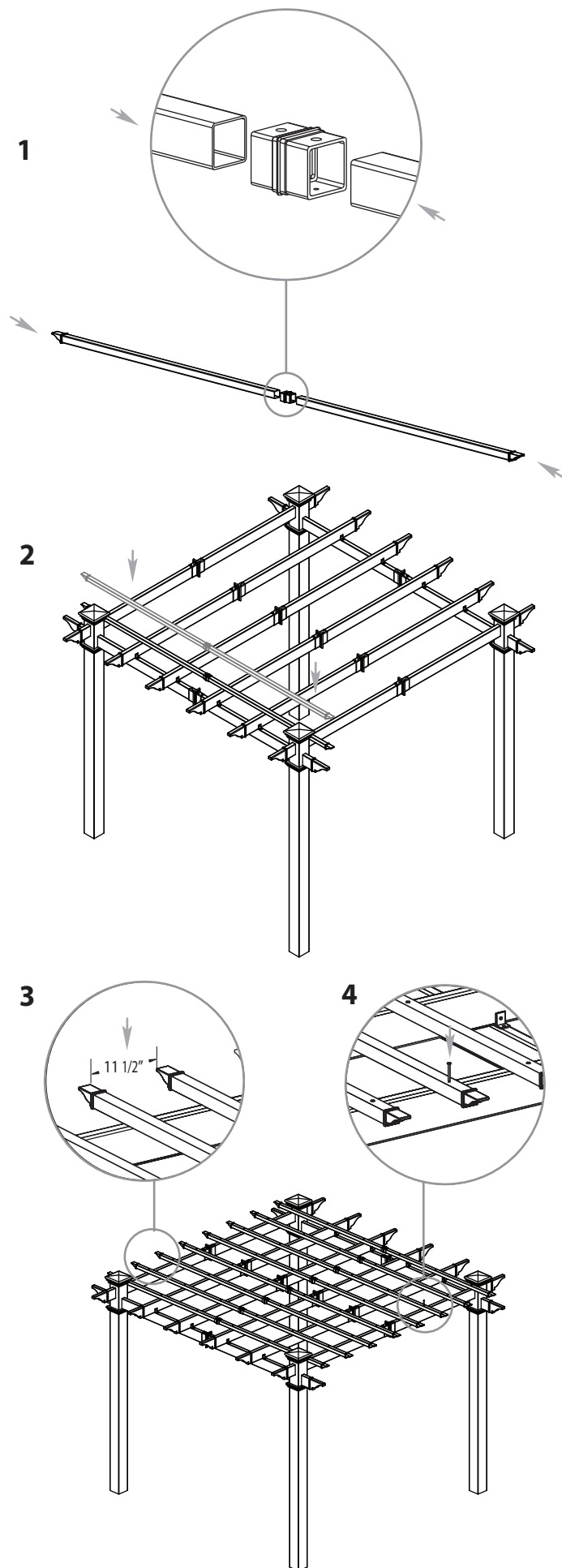

New England
Arbors
Leadership by Design
www.newenglandarbors.com