

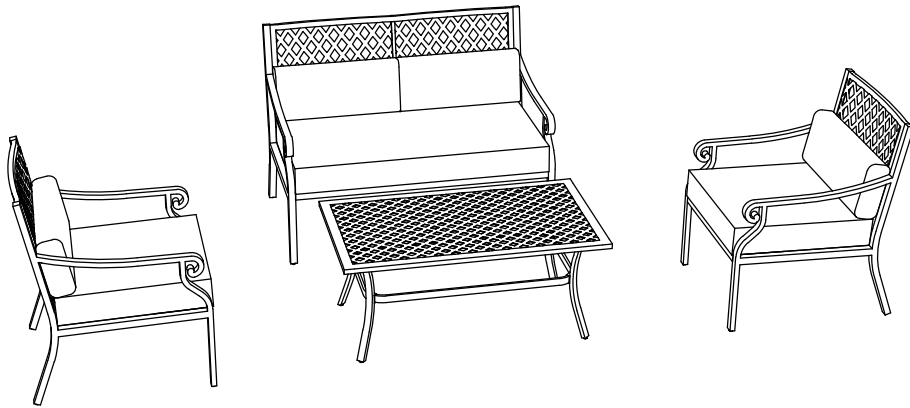



CROSLEY

FURNITURE



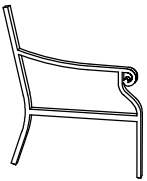
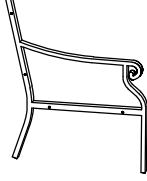
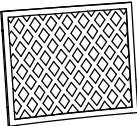
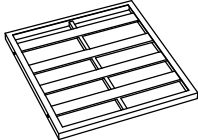
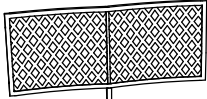
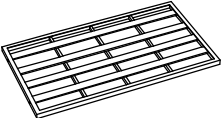
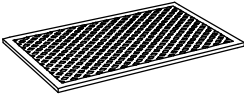

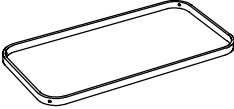
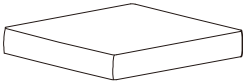
Outdoor Metal Conversation Set CO7395

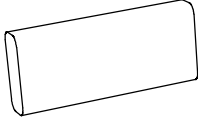

PART LIST

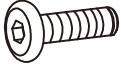
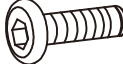
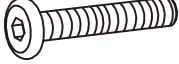
A 	B 	C  (arm chair)	D  (arm chair)	E  (loveseat)
Left Arm Panel 3 PCS	Right Arm Panel 3 PCS	Back Panel 2 PCS	Seat Panel 2 PCS	Back Panel 1 PC
F  (loveseat)	G 	H 	I 	J  (arm chair)
Seat Panel 1 PC	Top Panel 1 PC	Leg 4 PCS	Shelf 1 PC	Seat Cushion 2 PCS
K  (loveseat)	L 			
Seat Cushion 1 PC	Back Cushion 4 PCS			

HARDWARE LIST

#1  M6*12mm	#2  M8*12mm	#3  M6*35mm	#4  M6mm	#5  M8mm
Bolt 8 PCS (Extra 1)	Medium Bolt 4 PCS (Extra 1)	Long Bolt 25 PCS (Extra 1)	Flat Washer 33 PCS (Extra 1)	Large Flat Washer 4 PCS (Extra 1)
#6  M6mm	#7  M8mm			
Allen Wrench 1 PC	Large Allen Wrench 1 PC			

Step 1. Lay left arm panel (part A) down on a soft flat surface, such as carpet, as shown below. Attach seat panel (part D) to left arm panel (part A) using long bolts (part #3), flat washers (part #4) and allen wrench (part #6).

NOTE: Please do not fully tighten bolts until unit is fully assembled.

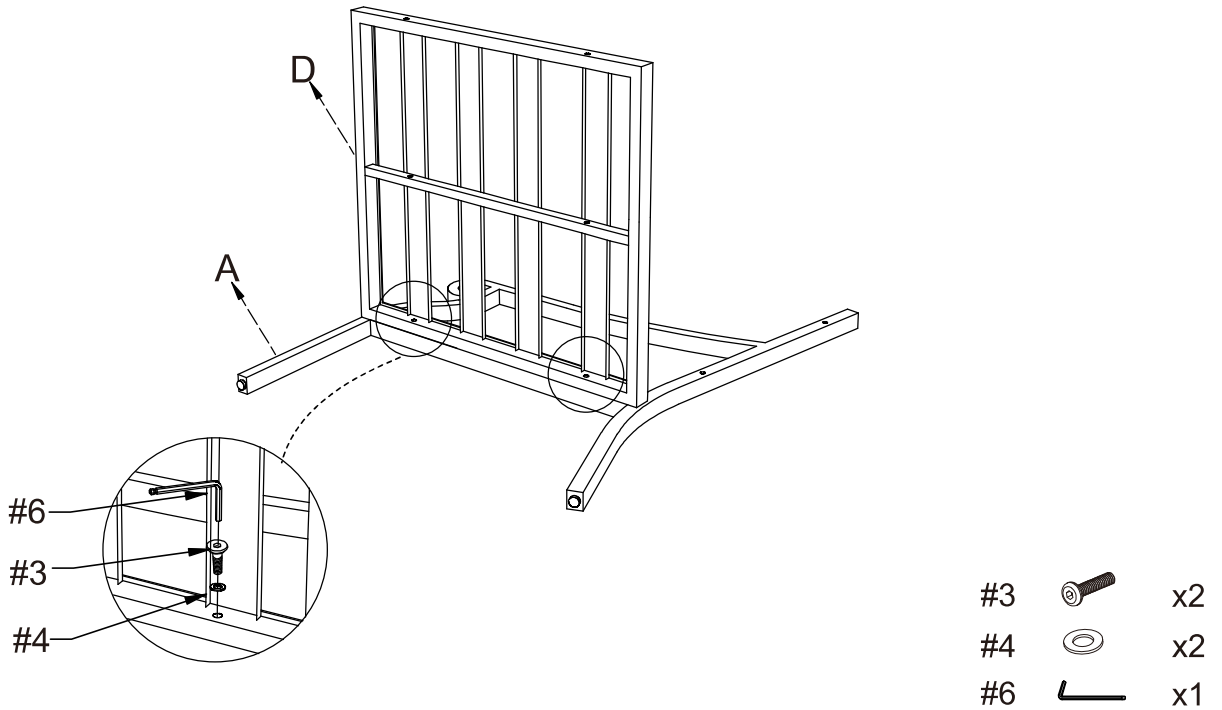

Step 2. Attach back panel (part C) to left arm panel (part A) and seat panel (part D) using long bolts (part #3), flat washers (part #4) and allen wrench (part #6).

NOTE: Please do not fully tighten bolts until unit is fully assembled.

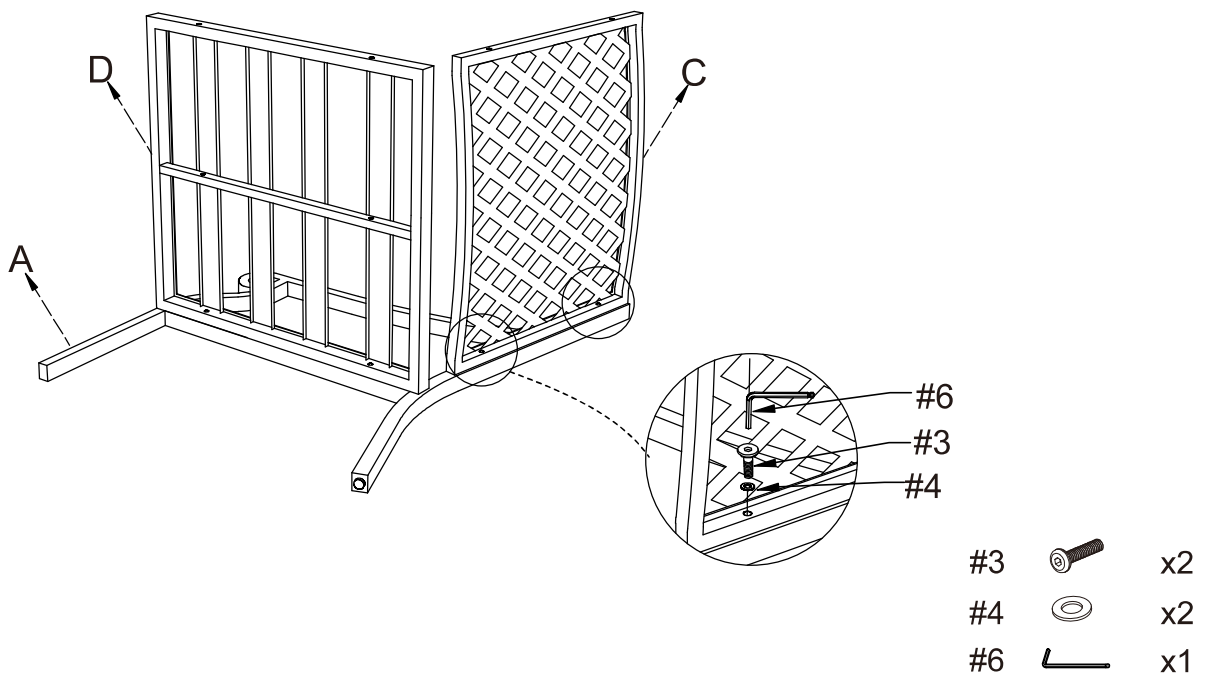

Step 3. Attach right arm panel (part B) to back panel (part C) and seat panel (part D) using long bolts (part #3), flat washers (part #4) and allen wrench (part #6).

NOTE: Please fully tighten all bolts at this time.

It is important to adjust levelers once fully assembled and upright. Extend adjustable leveler until it's firmly in contact with the floor. If relocating, adjust leveler as needed until it's firmly in contact with the floor in new location.

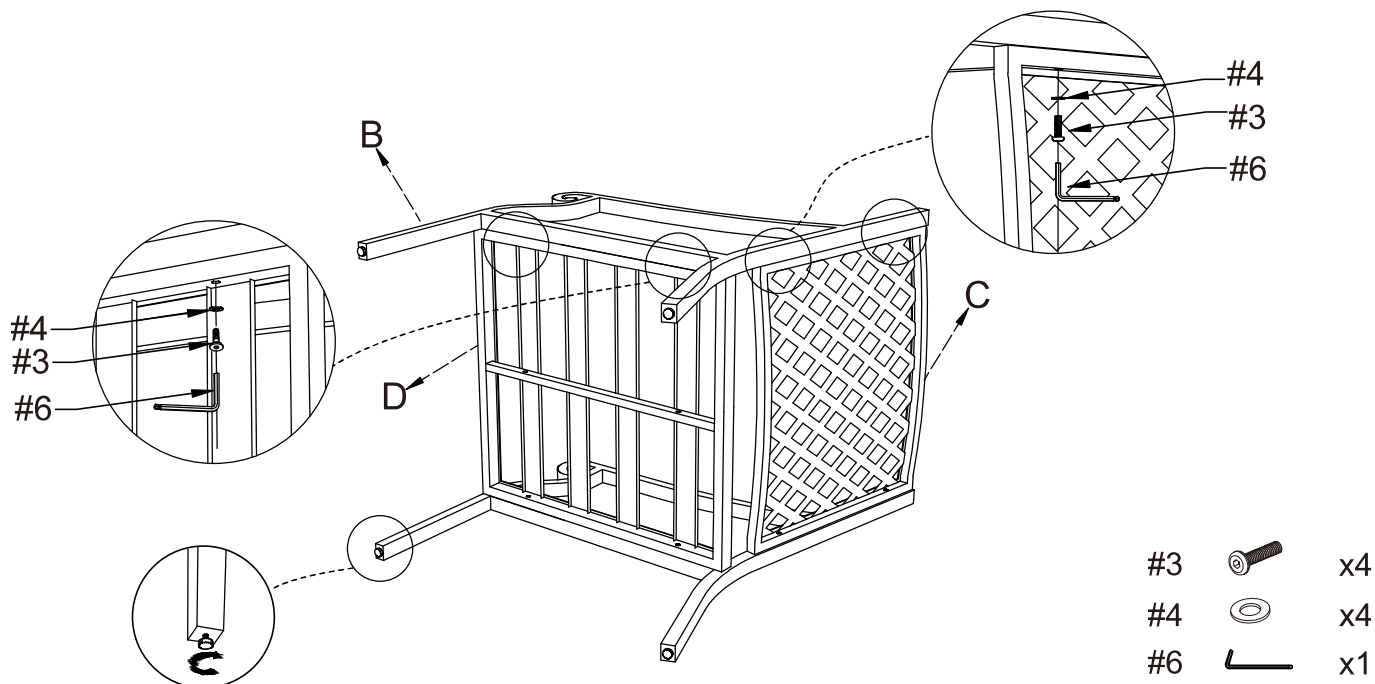

Step 4. Carefully turn unit upright. Place seat cushion (part J) and back cushion (part L) as shown below.

Repeat steps 1-4 to assemble remaining chair.

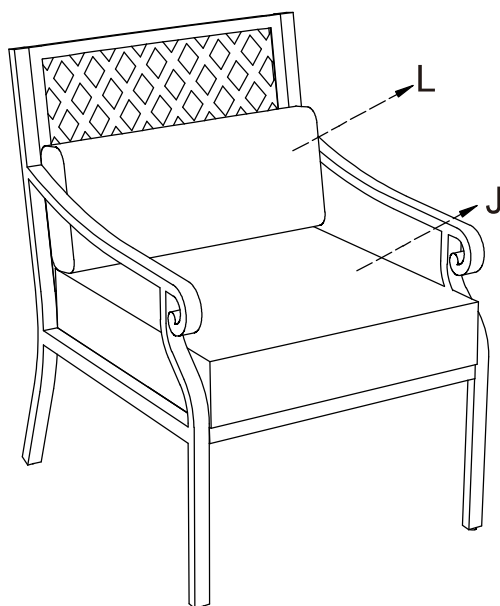

Step 5. Lay left arm panel (part A) down on a soft flat surface, such as carpet, as shown below. Attach seat panel (part F) to left arm panel (part A) using long bolts (part #3), flat washers (part #4) and allen wrench (part #6).

NOTE: Please do not fully tighten bolts until unit is fully assembled.

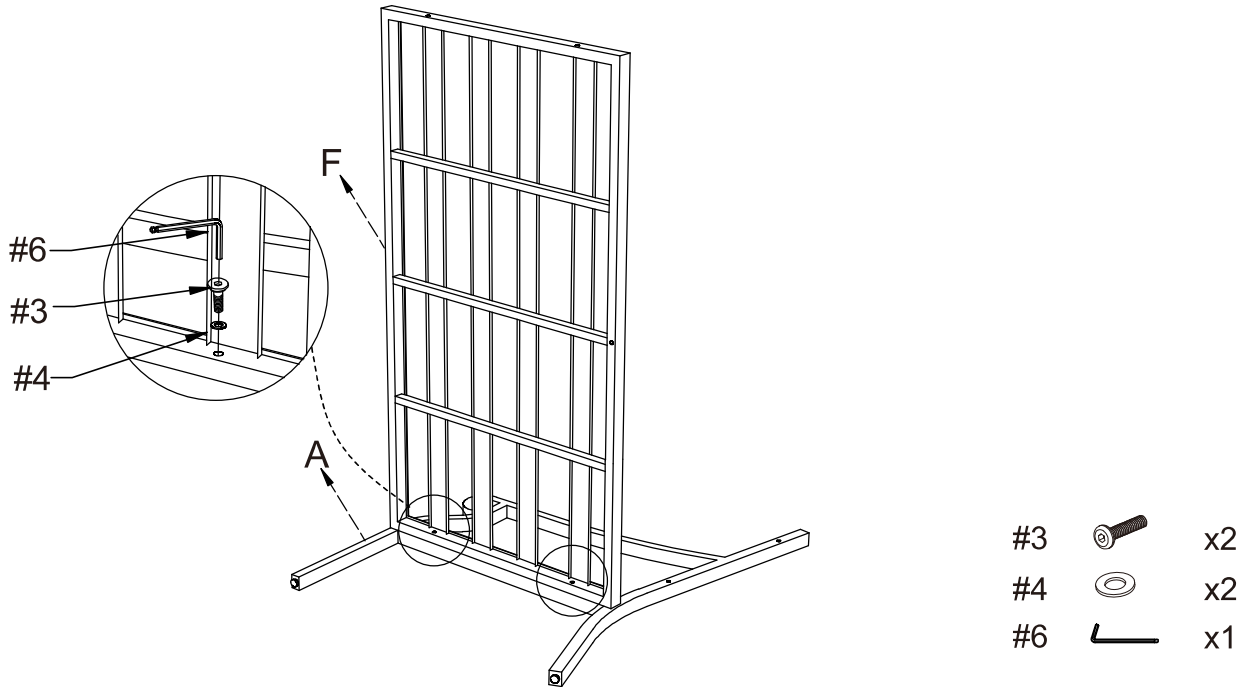

Step 6. Attach back panel (part E) to left arm panel (part A) and seat panel (part F) using long bolts (part #3), flat washers (part #4) and allen wrench (part #6).

NOTE: Please do not fully tighten bolts until unit is fully assembled.

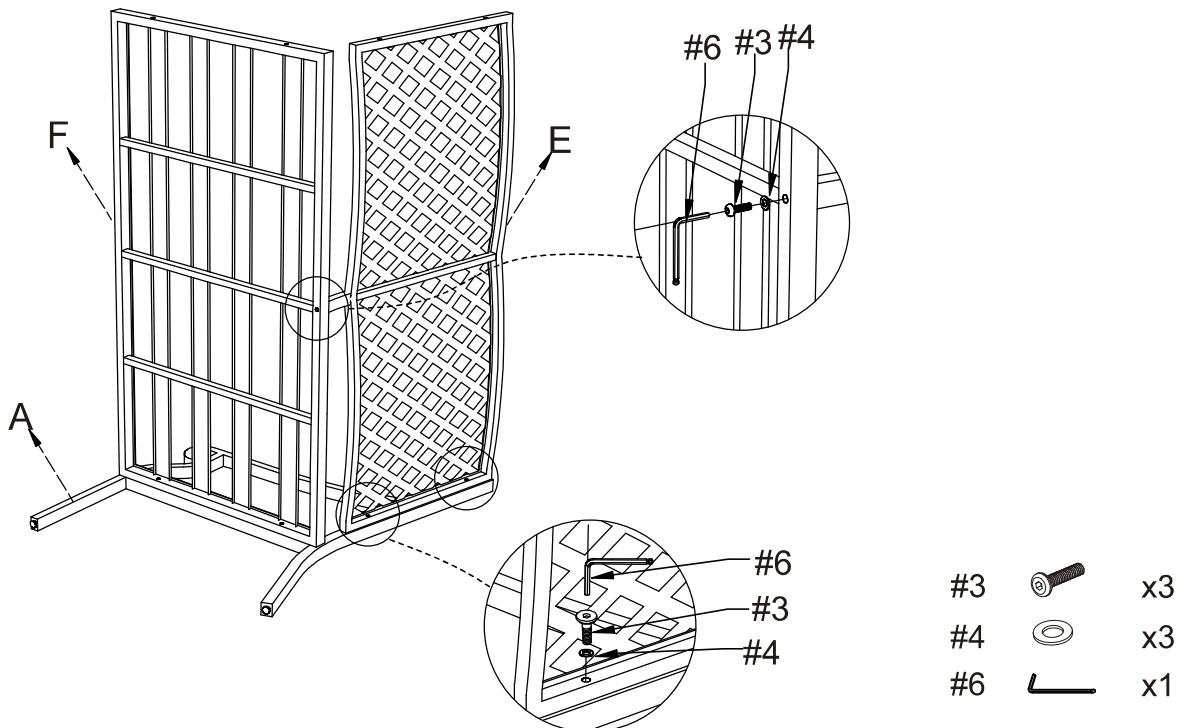

Step 7. Attach right arm panel (part B) to back panel (part E) and seat panel (part F) using long bolts (part #3), flat washers (part #4) and allen wrench (part #6).

NOTE: Please fully tighten all bolts at this time.

It is important to adjust levelers once fully assembled and upright. Extend adjustable leveler until it's firmly in contact with the floor. If relocating, adjust leveler as needed until it's firmly in contact with the floor in new location.

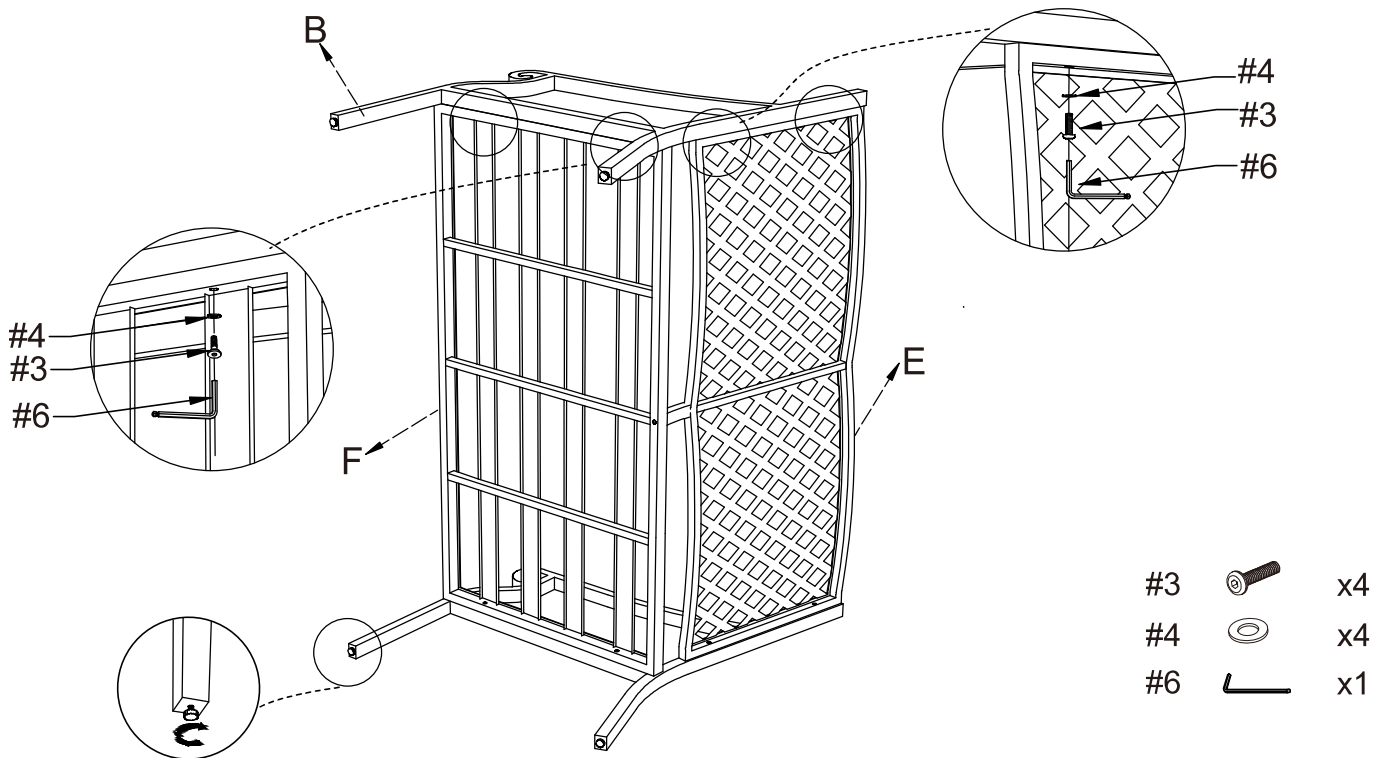

Step 8. Carefully turn unit upright. Place seat cushion (part K) and back cushions (part L) as shown below.

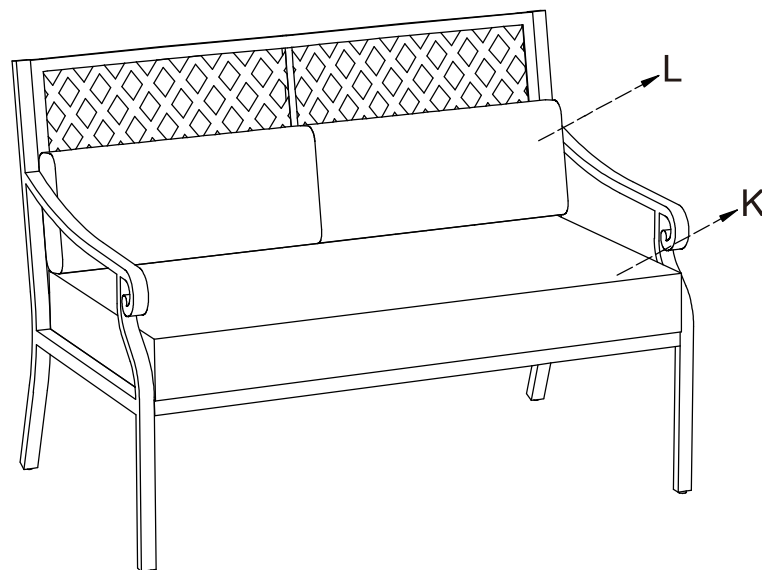

Step 9. Lay top panel (part G) upside down on a soft flat surface, such as carpet, as shown below. Attach legs (part H) to top panel (part G) using bolts (part #1), flat washers (part #4) and allen wrench (part #6).

NOTE: Please do not fully tighten bolts until unit is fully assembled.

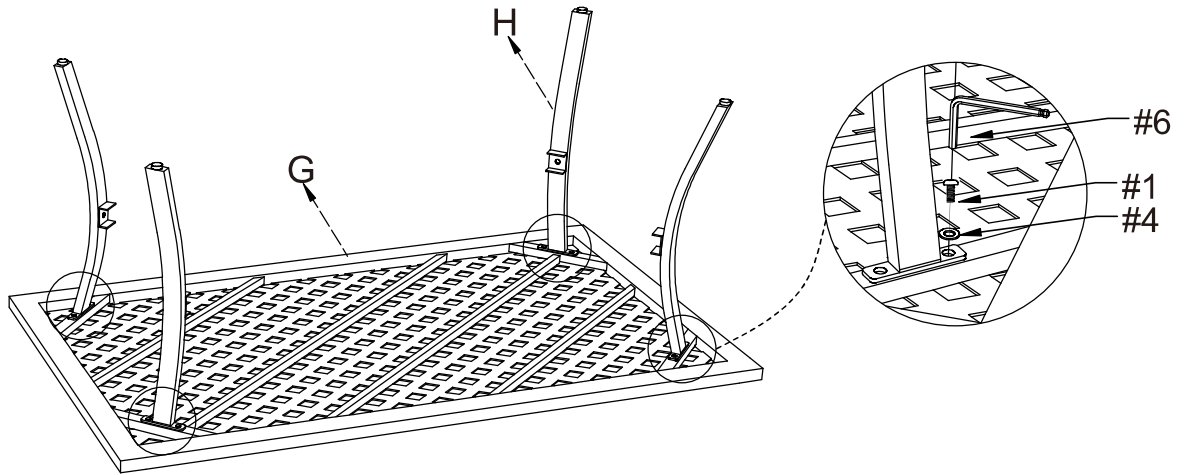



- | | | |
|----|--|----|
| #1 |  | x8 |
| #4 |  | x8 |
| #6 |  | x1 |

Step 10. Attach shelf (part I) to legs (part H) using medium bolts (part #2), large flat washers (part #5) and large allen wrench (part #7).

NOTE: Please fully tighten all bolts at this time.

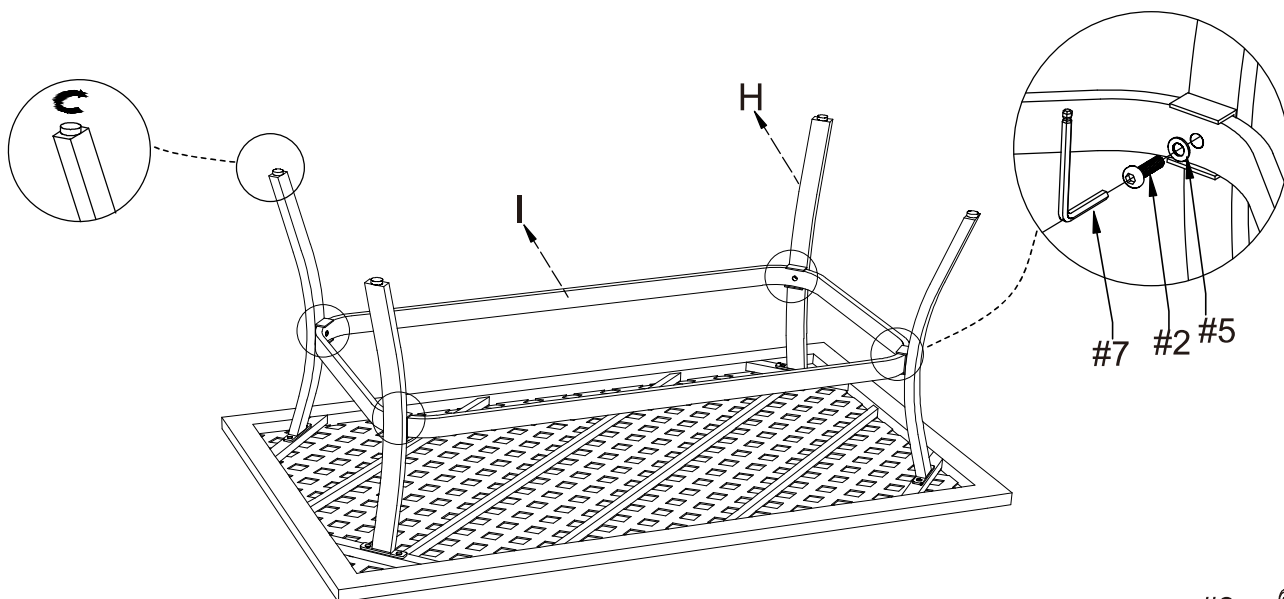
It is important to adjust levelers once fully assembled and upright. Extend adjustable leveler until it's firmly in contact with the floor. If relocating, adjust leveler as needed until it's firmly in contact with the floor in new location.



- | | | |
|----|---|----|
| #2 |  | x4 |
| #5 |  | x4 |
| #7 |  | x1 |

Step 11. Carefully turn unit upright.

