









# ASSEMBLY INSTRUCTION

Item#:5070-10459 Writing Desk

\*\* Please make sure you have all parts indicated below prior to assembly.  
This unit is heavy and can best be assembled with the help of two or more persons.

NO.	HARDWARE LIST		Q'TY
A		ALLEN WRENCH	1
B		BOLT	8
C		LOCK WASHER	10
D		FLAT WASHER	10
E		BOLT	2
F		SPANNER	1
G		NUT	2
H		DOWEL	4

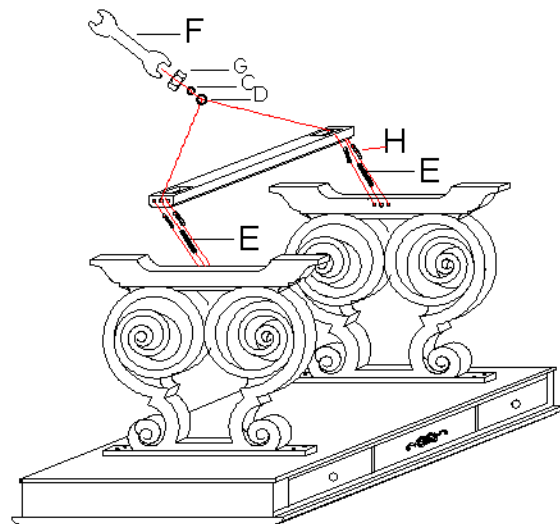
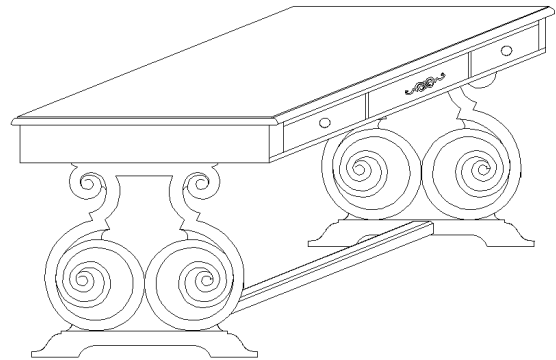

Diagram 1

Diagram 2

## Assembly Steps:

1. Place the writing desk top upside down on a soft surface to prevent from scratching the top.
2. Attach each base to the top, using 4 bolt (B), 4 lock washers (C), 4 flat washers (D), secure by turning with Allen Wrench (A) in a clockwise direction. Please do not turn the bolts tightly in this step. Then attach the other base in the same way. (See diagram 1).
3. Place the bottom rail on the base, insert 2pcs dowels (H) at each end of rail and then insert into two bases. (See diagram 2).
4. Insert 1pc full thread bolt (E) through the hole on each end of the rail into the hole on base by using 1 nut (G), 1 lock washer (C), 1 flat washer (D), secure by turning nut (G) with Spanner (F) in a clockwise direction. Please do not turn the bolts tightly in this step. (See diagram 2).
5. Adjust the bases and rail to be right place and then secure the bolts (B) by turning with Allen Wrench (A) tightly, secure the full thread bolts (E) by turning nut (G) with Spanner (F) tightly.
6. Turn the writing desk upright.

**Cleaning Instruction:** Clean finished parts with a damp cloth using a mild dishwashing liquid and water solution. Polish the finish with soft cloth and an industry recognized furniture polish.