

## SPECIFICATIONS

# TOLOSA

NativeStone® Collection

TOP VIEW

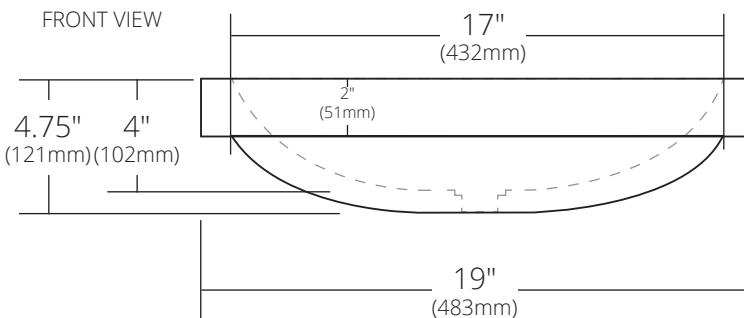
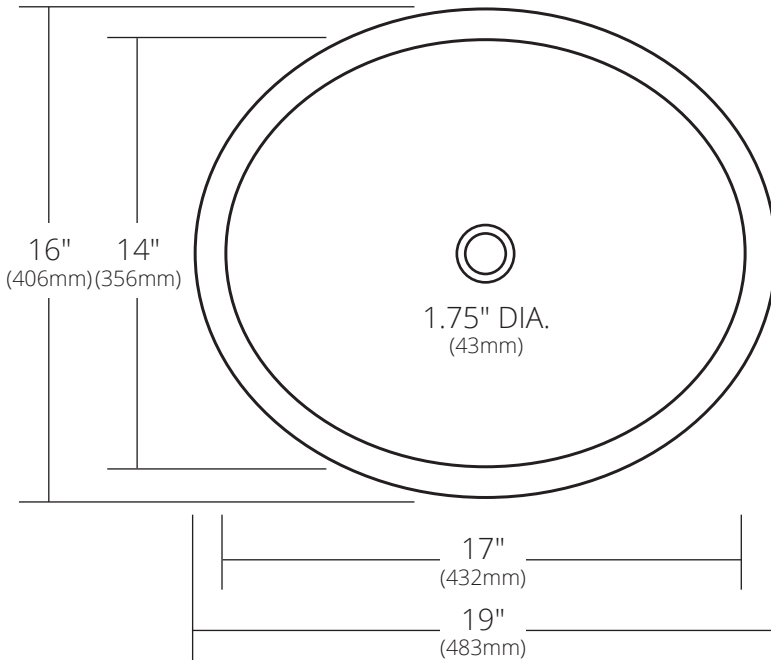

NSL1916-A Ash  
 NSL1916-C Charcoal  
 NSL1916-D Sand  
 NSL1916-E Earth  
 NSL1916-F Forest  
 NSL1916-G Sage  
 NSL1916-O Ocean  
 NSL1916-P Pearl  
 NSL1916-S Slate  
 NSL1916-T Terracotta

### PRODUCT DETAILS

- 19" x 16" x 4.75" OD (483mm x 406mm x 121mm)
- 17" x 14" x 4" ID (432mm x 356mm x 102mm)
- 1.75" (43mm) drain opening
- Handcrafted from sustainable NativeStone
- Sealed with NativeStone Shield™
- Weight: approx. 15lbs

### INSTALLATION

- Drop-In or Undermount

### COORDINATING PRODUCTS

- Drains: DR120, DR130 or DR150
- UK1426 Undermount Kit

### STANDARDS COMPLIANCE

- UPC/cUPC compliant
- **ADA** COMPLIANT

### IMPORTANT

Do NOT use tape or other adhesives on NativeStone as it may remove the sealer.

Due to the handcrafted nature of this product, it will vary in finish, texture, and other details. Dimensions may vary up to 1/4" (6mm). We strongly recommend waiting for the actual product before making any installation cuts.